

© CERTIFIED BY TORONTO HYDRO STANDARD <STANDARDS@TORONTOHYDRO.COM>; THIS DOCUMENT IS FOR USE BY TORONTO HYDRO AND AUTHORIZED PERSONS ONLY AS PER THE TERMS IN TORONTO HYDRO STANDARD 00-0002.

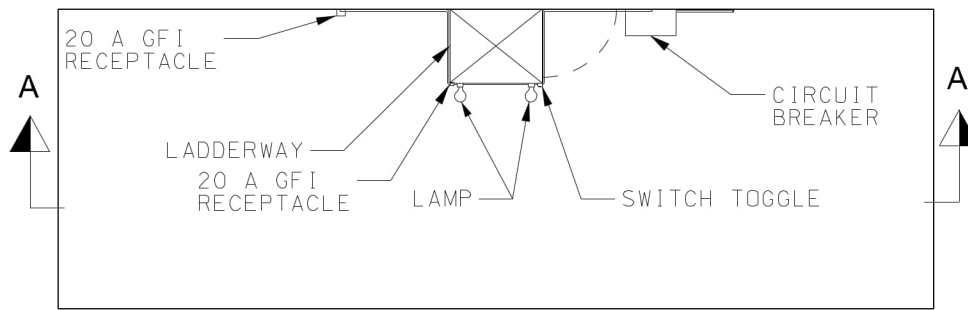

PLAN VIEW
TWO UNIT VAULT

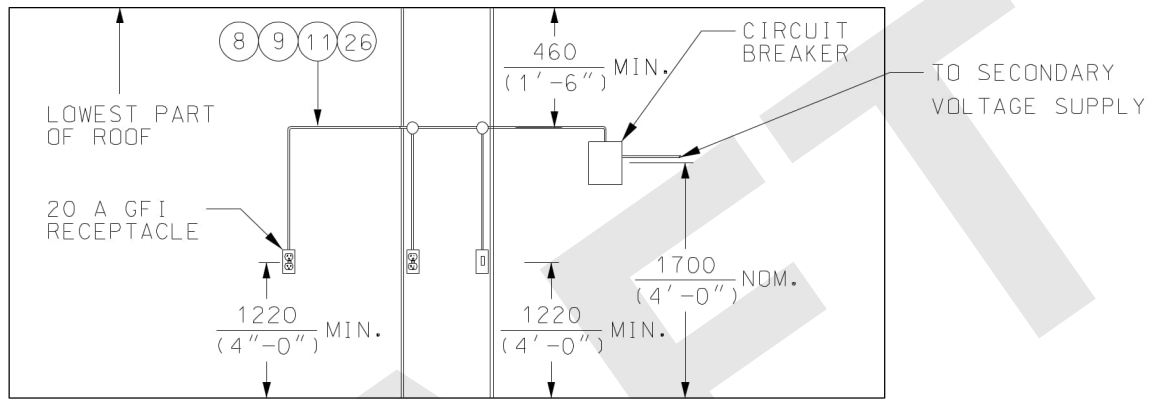

SECTION 'A-A'

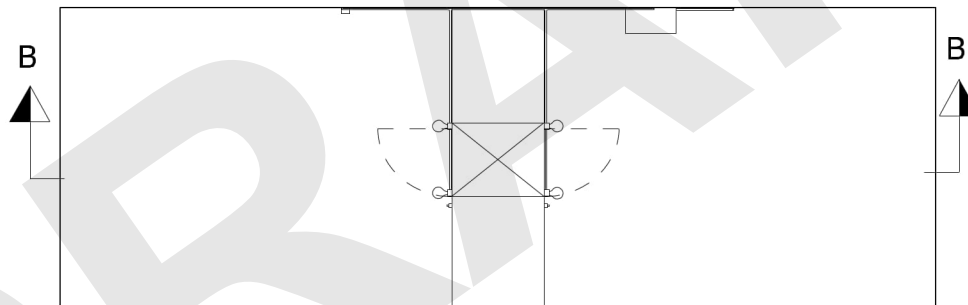

PLAN VIEW
TWO UNIT VAULT (SPLIT VAULT)

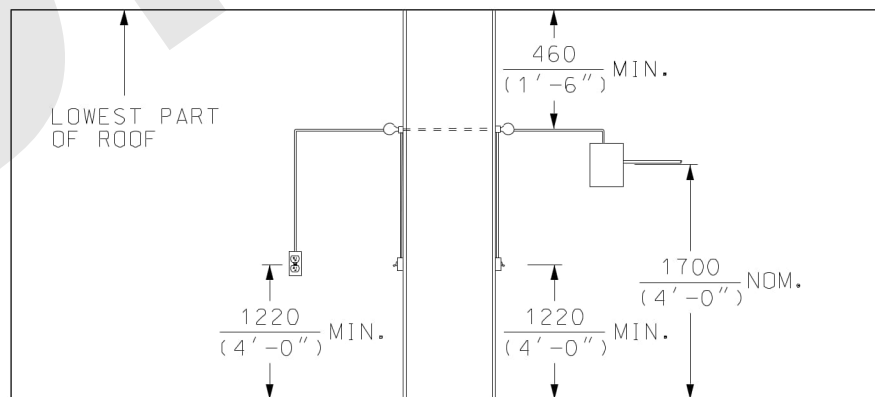

SECTION 'B-B'

DISTRIBUTION CONSTRUCTION STANDARD
UG Transformers and Switchgears

VAULT LIGHTING ARRANGEMENT



Approved By:
I. S. 2020-02-20
Drafted By:
L. L.
Designed By:
S. K.

Original Issue:
K. S. 2009-09-08

Scale:
N. T. S.

Rev:

3

13-2200

1/3

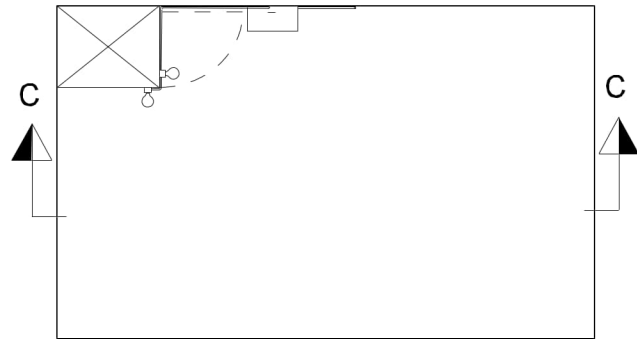

PLAN VIEW
SINGLE UNIT VAULT - NON-URD

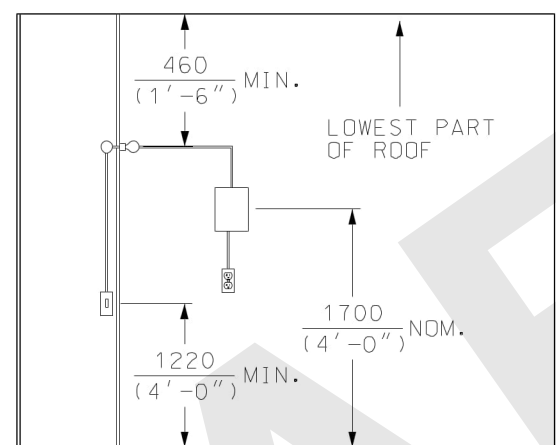

SECTION 'C-C'

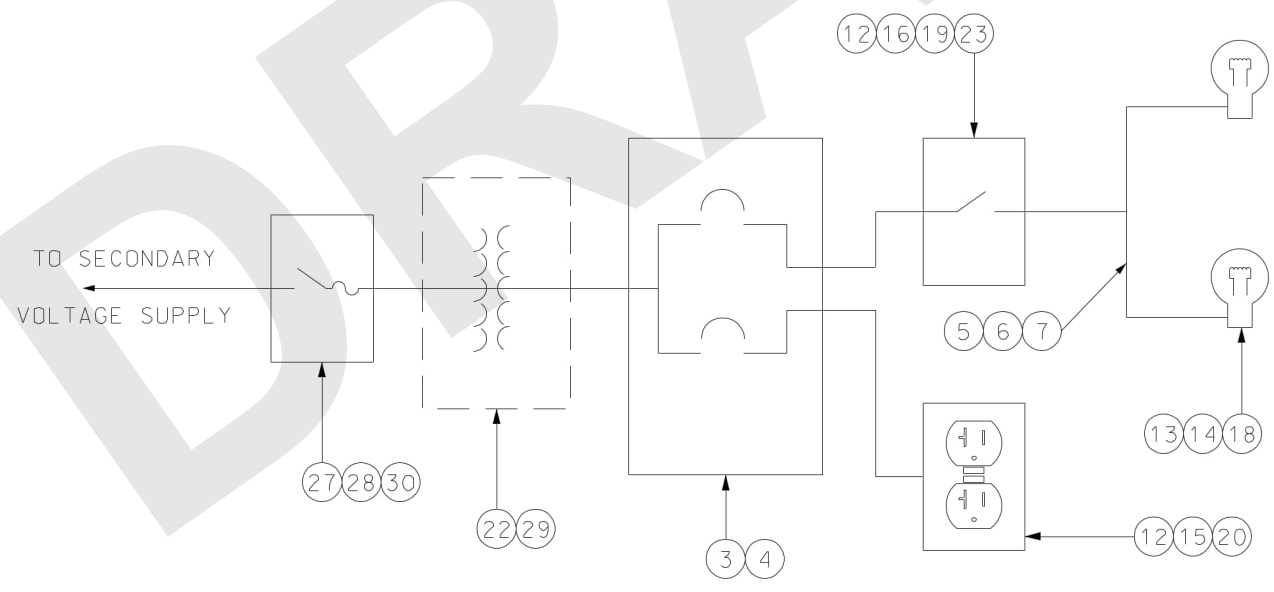

WIRING SCHEMATIC

DISTRIBUTION CONSTRUCTION STANDARD
UG Transformers and Switchgears

VAULT LIGHTING ARRANGEMENT



Approved By:
I. S. 2020-02-20
Drafted By: L. L.
Designed By: S. K.

Original Issue:
K. S. 2009-09-08

Scale:
N. T. S.

Rev: **3**

13-2200

2/3

BOM LEGEND	
A	2 UNIT TRANSFORMER 120/208 V ROOM / VAULT
B	2 UNIT TRANSFORMER 347/600 V ROOM / VAULT
C	1-PHASE TRANSFORMER URD SYSTEM
D	3-PHASE 120/208 V TRANSFORMER URD SYSTEM
E	3-PHASE 347/600 V TRANSFORMER URD SYSTEM
F	3-PHASE 200 A SWITCH URD SYSTEM
G	3-PHASE 600 A SWITCH URD SYSTEM
H	MODULAR SWITCH
I	1 UNIT TRANSFORMER 120/208 V ROOM / VAULT
J	2 UNIT TRANSFORMER 240/416 V ROOM / VAULT
K	1 UNIT TRANSFORMER 240/416 V ROOM / VAULT
L	1 UNIT TRANSFORMER 347/600 V ROOM / VAULT

BILL OF MATERIALS FOR 13-2200

ITEM NO.	DESCRIPTION	ITEM I.D.	QUANTITY											
			A	B	C	D	E	F	G	H	I	J	K	L
1	STRAP PIPE FOR 1/2" 1 HOLE COATED	100000653	15	15	10	15	15	10	15	18	15	15	15	15
2	ANCHOR THREADED CONCRETE 1/4" X 1 1/4"	2500100	30	30	20	30	30	20	30	40	30	30	30	30
3	PANEL CIRCUIT BREAKER 70 A 120/240 V	9656560	1	1	1	1	1	1	1	1	1	1	1	1
4	BREAKER CIRCUIT 20 A 120 V	9656680	2	2	2	2	2	2	2	2	2	2	2	2
5	CABLE #12 STR CU TW75 600 V BLACK	7150100	25	25	20	25	25	20	25	25	25	25	25	25
6	CABLE #12 STR CU TW75 600 V WHITE	7150102	20	20	10	20	20	10	20	20	20	20	20	20
7	CABLE #12 STR CU TW75 600 V GREEN	7150098	20	20	10	20	20	10	20	20	20	20	20	20
8	CONDUIT PVC RIGID 1/2" IN 10' LENGTHS	5230000	5	5	5	5	5	5	6	6	5	6	5	5
9	COUPLING PVC 1/2" FOR CONDUIT	5231027	6	6	6	6	6	6	6	6	6	6	6	6
10	ADAPTER MALE PVC 1/2" FOR CONDUIT	5232000	11	13	11	11	13	11	13	12	11	13	11	11
11	BEND PVC 1/2" 90 DEG FOR CONDUIT	5233000	5	5	5	5	5	5	5	5	5	5	5	5
12	BOX UTILITY PVC 2" DEEP FOR 1/2" CONDUIT	7405002	2	2	2	2	2	2	2	2	2	2	2	2
13	BOX OCTOGON PVC 4" X 1 1/2" DEEP FOR 1/2" CONDUIT	7405003	3	3	2	3	3	3	3	3	3	4	3	3
14	LAMPHOLDER PORCELAIN 660 W 250 V KEYLESS	7440020	2	2	2	2	2	2	2	2	2	4	2	2
15	COVER PVC DUPLEX RECEPTACLE	7446000	1	1	1	1	1	1	1	1	1	1	1	1
16	COVER PVC TOGGLE SWITCH	7446002	1	1	1	1	1	1	1	2	1	2	1	1
17	TAPE PVC 3/4" X .0075" MIN LDW TEMPERATURE	7600001	1	1	1	1	1	1	1	1	1	1	1	1
18	LAMP 300 W 125/130 V PS30	8010051	2	2	2	2	2	2	2	2	2	4	2	2
19	SWITCH TOGGLE APPLIANCE 20 A 1 WAY	9653473	1	1	1	1	1	1	1	-	1	2	1	1
20	RECEPTACLE GROUND FAULT 20 A 125 V	9665648	1	1	1	1	1	1	1	1	1	1	1	1
21	LOCKNUT 1/2" CONDUIT	9655483	10	13	10	10	13	10	10	11	10	13	10	10
22	TRANSFORMER DRY TYPE 1PH 3 KVA 600-120/240 V	6621501	-	1	-	-	1	-	-	-	-	-	-	1
23	SWITCH TOGGLE APPLIANCE 20 A 3 WAY	9653472	-	-	-	-	-	-	-	2	-	-	-	-
24	CONNECTOR CU SPLIT U-BOLT #1-4/0 STR	7213000	1	1	1	1	1	1	1	1	1	1	1	1
25	CABLE #12 STR CU TW75 600 V RED	7190060	-	-	-	-	-	-	-	10	-	-	-	-
26	CEMENT SOLVENT FOR RIGID PVC CONDUIT	9652392	1	1	1	1	1	1	1	1	1	1	1	1
27	SWITCH SAFETY HEAVY DUTY 30A 600V AC	9653443	-	1	-	-	1	-	-	-	-	1	1	1
28	FUSE 600V 10A	7073017	-	2	-	-	2	-	-	-	-	-	-	2
29	TRANSFORMER DRY TYPE 1PH 3KVA 250V-120V	9662764	-	-	-	-	-	-	-	-	-	1	1	-
30	FUSE 600V 15A	9651286	-	-	-	-	-	-	-	-	-	2	2	-

* SEE NOTE 3

NOTES:

- 1) LIGHTING LAYOUTS IN THIS STANDARD ARE TO BE USED AS A GUIDELINE. LIGHTS AND ACCESORIES ARE TO BE ARRANGED TO SUIT SITE CONDITIONS.
- 2) 3 WAY TOGGLE SWITCHES SHALL BE INSTALLED NEAR EACH OF VAULT DOORS IN MODULAR SWITCHING VAULT.
- 3) QUANTITIES OF SOME MATERIALS MAY VARY DUE TO SIZE AND LAYOUT.
- 4) 1-PHASE TRANSFORMER AND 200 A SWITCH VAULT ON URD SYSTEM REQUIRES 1 LIGHT.
- 5) ALL EQUIPMENT TO BE MOUNTED ON WALLS IN URD NETWORK VAULTS.

DISTRIBUTION CONSTRUCTION STANDARD
UG Transformers and Switchgears

VAULT LIGHTING ARRANGEMENT



Approved By:
I. S. 2020-02-20

Drafted By: L.L.
Designed By: S.K.

Original Issue:
K.S. 2009-09-08

Scale:
N.T.S.

Rev. **3**

13-2200

3/3

© CERTIFIED BY TORONTO HYDRO STANDARD <STANDARDS@TORONTOHYDRO.COM>, THIS DOCUMENT IS FOR USE BY TORONTO HYDRO AND AUTHORIZED PERSONS ONLY AS PER THE TERMS IN TORONTO HYDRO STANDARD 00-0002.

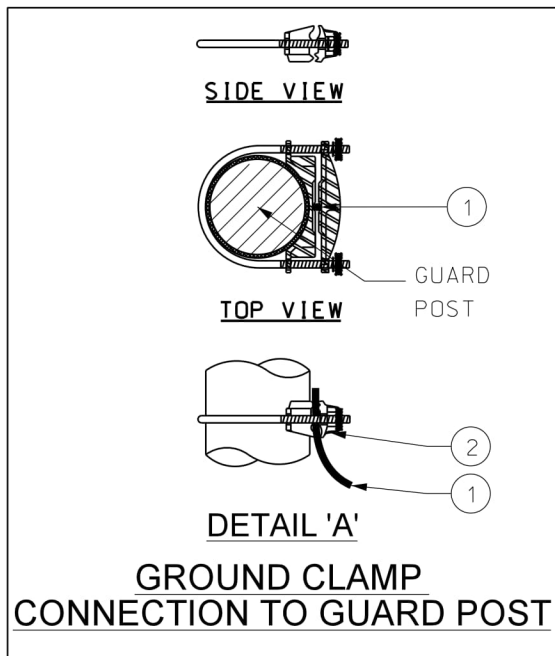
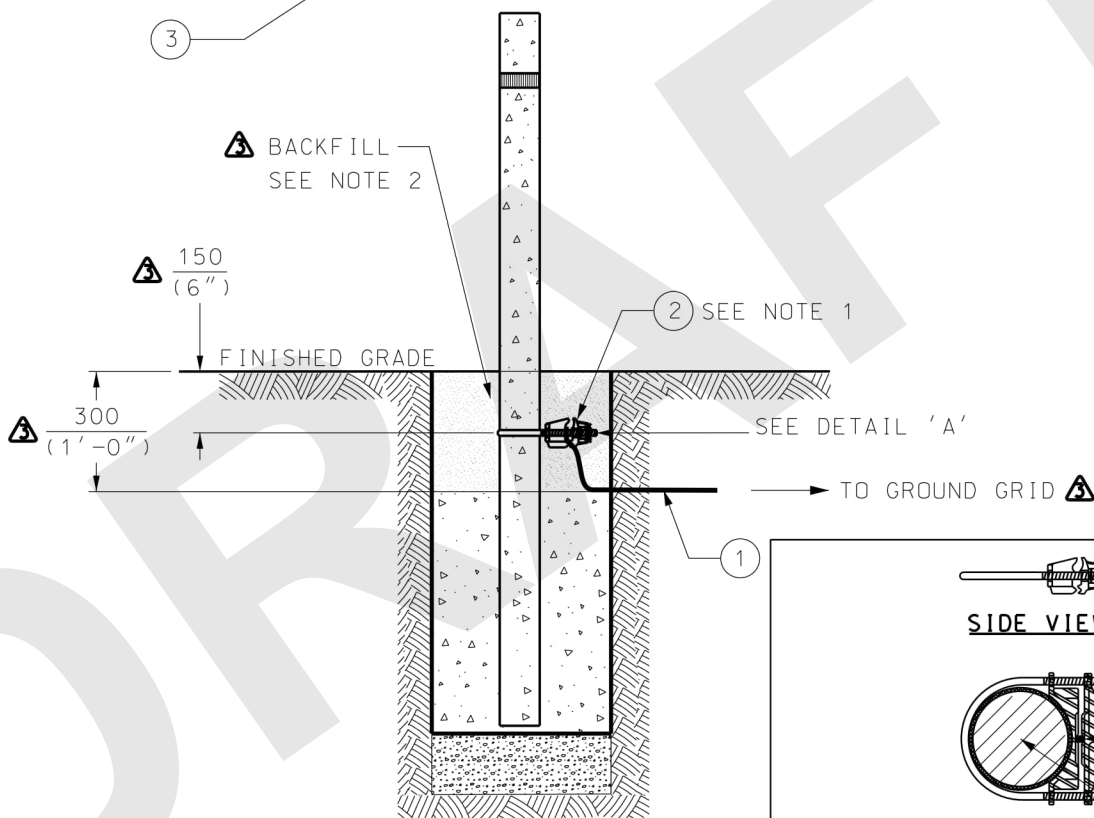
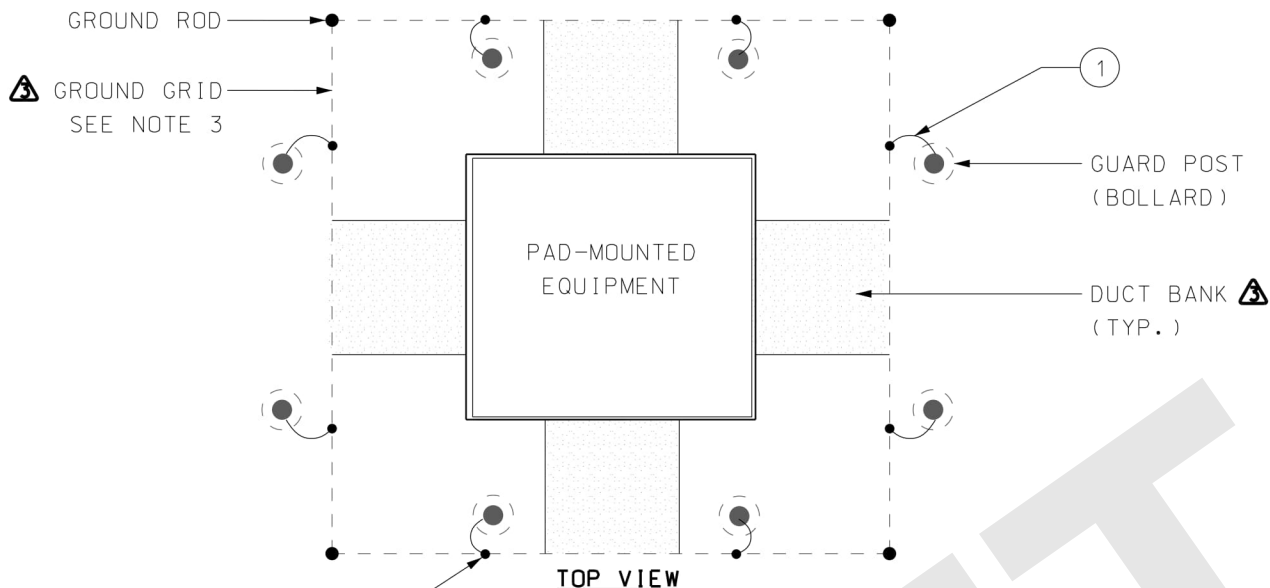

NOTES:

- 1) GROUND CONNECTOR SHALL BE CLAMPED TO NON-PAINTED SURFACE OF THE GUARD POST.
- 2) REFER TO STD. 31-4080 FOR GUARD POST INSTALLATION.
- 3) REFER TO STD. 18-5500 FOR GROUND GRID OF PAD-MOUNTED EQUIPMENT.
- ⚠ 4) ALL METALLIC GUARD POSTS (BOLLARDS) WITHIN 2400 mm (8'-0") OF PAD-MOUNTED EQUIPMENT ENCLOSURE SHALL BE INTERCONNECTED WITH THE GROUND GRID OF THE PAD-MOUNTED EQUIPMENT.

DISTRIBUTION CONSTRUCTION STANDARD
Grounding

**UNDERGROUND SYSTEMS
GUARD POST GROUNDING DETAIL**



Approved By:
T.T. 2015-11-24
Drafted By:
B.W.
Designed By:
E.H.

Original Issue:
K.S. 2013-06-12

Scale:
N.T.S.

Rev: **3**

18-5000

1/2

BOM LEGEND			
	BOLLARD SIZE	TYPE	APPLICATION
A	125 mm (5")	GALVANIZED PIPE	1-PHASE TRANSFORMER
			3-PHASE TRANSFORMER
			SWITCHGEAR

BILL OF MATERIALS FOR 18-5000				
ITEM NO.	DESCRIPTION	ITEM I.D.	QTY	A
1	WIRE #2/0 19 STR CU SD	7105160	1	
2	CONNECTOR CU GROUND CLAMP 5" PIPE - #4 TO #2/0	7214140	1	
3	CONNECTOR CU PARALLEL GRV COMPRESSION - #2/0 RUN TO #2/0 TAP	7213156	1	

* QUANTITIES SHOWN ARE PER BOLLARD.

DRAFT

DISTRIBUTION CONSTRUCTION STANDARD
Grounding

UNDERGROUND SYSTEMS
GUARD POST GROUNDING DETAIL



Approved By:
T. T. 2015-11-24

Drafted By:
B. W.

Designed By:
E. H.

Original Issue:
K. S. 2013-06-12

Scale:
N. T. S.

Rev:

3

18-5000

2/2

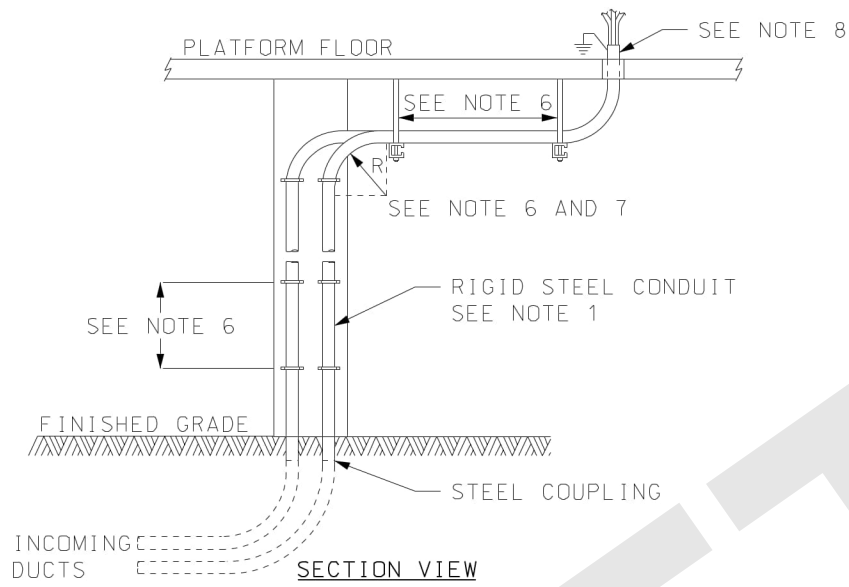

SERVICE TYPE	SIZE AND TYPE OF CABLE	ITEM I.D.	MIN. CONDUIT SIZE FOR 3 CONDUCTOR
13.8 kV	#1/0 3-1C TRIPLEX 15 kV AL TRXLPE	7180016	3"
13.8 kV	#3/0 3-1C TRIPLEX 15 kV CU TRXLPE	7180020	3"
13.8 kV	500 kcmil 3-1C TRIPLEX 15 kV CU TRXLPE	7180032	4"

NOTES:

- 1) RIGID NON-FERROUS THREADED STEEL CONDUIT TO BE USED FOR CABLE ROUTING. CONDUIT SHALL HAVE TAPERED THREAD AND BE MADE WATERTIGHT.
- 2) CONDUITS SHALL BE SECURELY ATTACHED TO HANGERS OR TO A SOLID SURFACE. THE TYPE OF SUPPORTS USED TO BE DETERMINED BASED ON FIELD CONDITIONS.
- 3) CONDUIT SIZE SHALL BE IN ACCORDANCE WITH TABLE 1 AND BE OF SUFFICIENT SIZE TO PERMIT THE CONDUCTORS TO BE DRAWN IN AND WITHDRAWN WITHOUT DAMAGE TO THE CABLES.
- 4) THE INCOMING PRIMARY SERVICE CABLES SHALL HAVE A DEDICATED CONDUIT PER RUN AND SHALL NOT BE SHARED WITH OTHER SERVICES, CONDUCTORS OR NEUTRAL.
- 5) THERE SHALL BE NO CABLE JOINTS OR SPLICES WITHIN CONDUIT.
- 6) CONDUIT SHALL BE SUPPORTED AT MAXIMUM 3000 mm (9'-10") INTERVALS AS WELL AS BEFORE AND AFTER ALL CHANGES OF DIRECTION.
- 7) CONDUIT BEND RADII AND CABLE PULLING FORCES SHALL NOT EXCEED THE LIMITS REFERENCED IN STD. 16-0220, 16-0260 AND 16-1260.
- 8) WHERE A CONDUIT ENTERS A BOX, FITTING, OR OTHER ENCLOSURE, A BUSHING SHALL BE PROVIDED TO PROTECT THE CABLE FROM ABRASION UNLESS THE DESIGN OF THE BOX, FITTING, OR ENCLOSURE IS SUCH AS TO AFFORD EQUIVALENT PROTECTION. ALL CUT ENDS SHALL BE REAMED OR OTHERWISE FINISHED TO REMOVE ROUGH EDGES.
- 9) WEATHERPROOF LABEL WILL BE AFFIXED AT REGULAR INTERVALS AROUND THE CONDUIT IN BLACK TEXT AGAINST AN ORANGE BACKGROUND THAT READS "DANGER HIGH VOLTAGE" ALONG WITH THE SYSTEM VOLTAGE, I.E. DANGER HIGH VOLTAGE 13800 V.
- 10) CONDUIT SHALL BE BONDED TO GROUND BUS OR GROUND LOOP OF INCOMING SWITCHGEAR. BONDING CABLE TO BE STRANDED BARE CU, NO SMALLER THAN #2/0, AND SECURED RELIABLY TO CONDUIT VIA MECHANICAL GROUND CONNECTOR.
- 11) IF EXPANSION JOINTS USED, BONDING JUMPERS ON CONDUIT ARE REQUIRED TO MAINTAIN CONTINUITY ACROSS JOINT.

DISTRIBUTION CONSTRUCTION STANDARD
UG Secondary and Primary Services

**TEMPORARY PRIMARY SERVICES
CONDUIT ROUTING**

	Approved By: B.L. 2018-03-01		Original Issue:	Scale: N.T.S.	Rev: 0	15-8510	1/1
	Drafted By: B.W.	Designed By: B.L.					

© CERTIFIED BY TORONTO HYDRO STANDARD <STANDARDS@TORONTOHYDRO.COM>; THIS DOCUMENT IS FOR USE BY TORONTO HYDRO AND AUTHORIZED PERSONS ONLY AS PER THE TERMS IN TORONTO HYDRO STANDARD 00-0002.

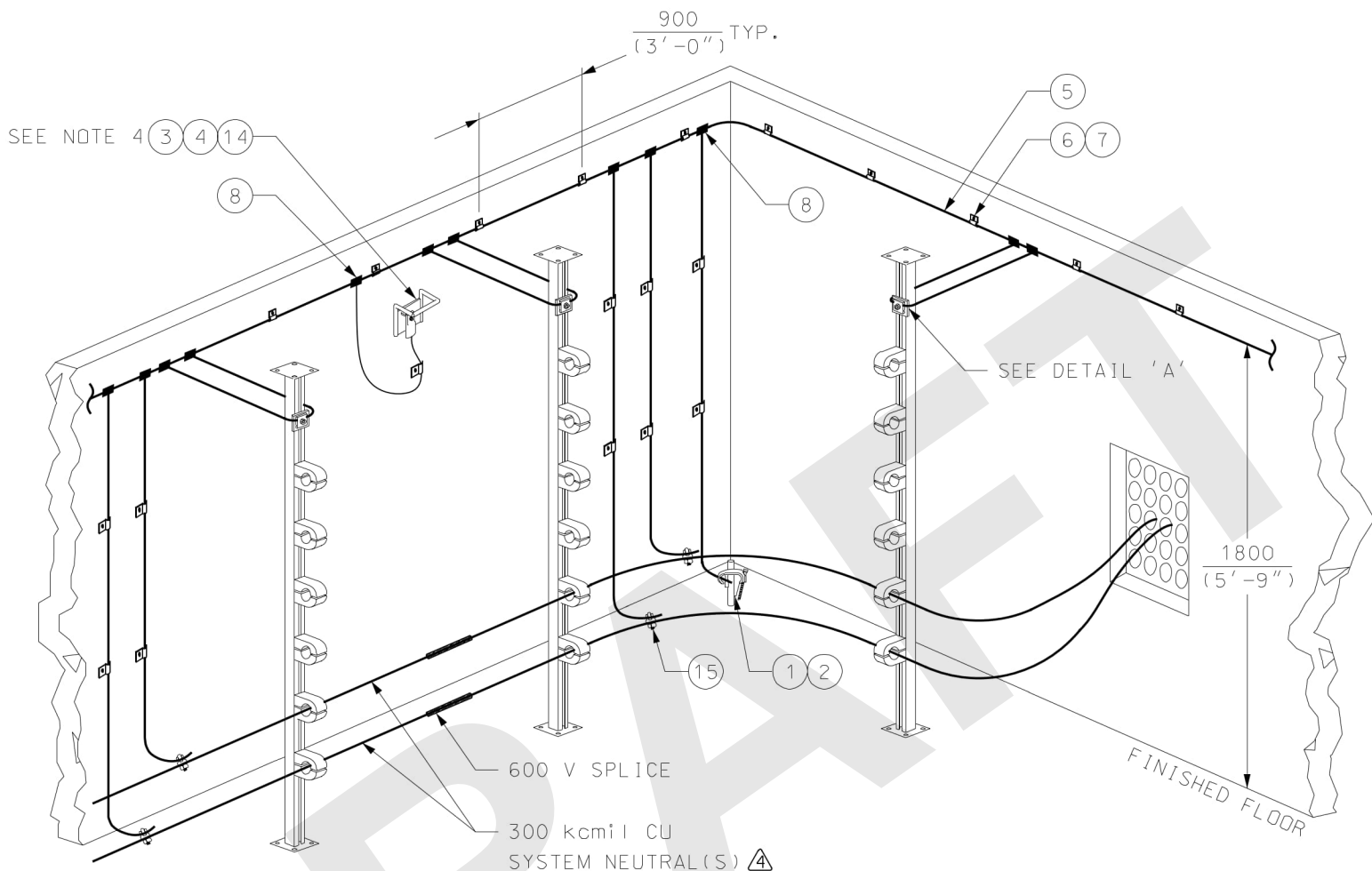

⚠ NOTES:

- 1) FOUR GROUND RODS SHALL BE INSTALLED NEAR THE CORNERS OF CABLE CHAMBER.
- 2) USE #2/0 BARE COPPER CONDUCTOR FOR GROUND LOOP AND CONNECTIONS TO GROUND RODS.
- 3) ALL NEUTRALS SHALL BE CONNECTED TO GROUND LOOP.
- 4) STIRRUP SHALL BE INSTALLED WHERE SPACE IS AVAILABLE TO ALLOW FOR PROPER GROUNDING PROVISIONS.

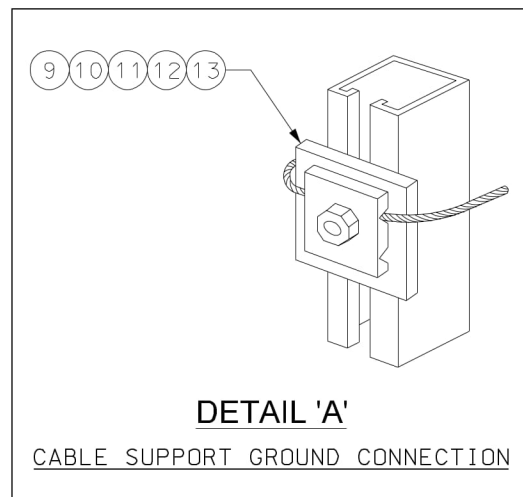

DISTRIBUTION CONSTRUCTION STANDARD
Grounding



Approved By:
E. M. 2017-03-31

Drafted By:
B. W.

Designed By:
E. H.

Original Issue:
C. P. 2001-01-10

Scale:
N. T. S.

Rev:
4

18-5100

1/2

**UNDERGROUND SYSTEM
CABLE CHAMBER GROUNDING**



BILL OF MATERIALS FOR 18-5100			
ITEM NO.	DESCRIPTION	ITEM I.D.	QTY
1	ROD 3/4" X 10' STEEL GALVANIZED	2470102	4
2	CONNECTOR 3/4" ROD TO #2/0 CU	7214200	4
3	CONNECTOR CU TERMINAL LUG TINNED #2/0 STR 1/2" HOLE	9662106	2
4	ANCHDR CONCRETE SLEEVE 1/2" X 3" LONG	9653086	2
5	WIRE #2/0 19 STR CU SD	7105160	43
6	CLIP CABLE CSA - CONDUCTOR MOUNTING	7210190	36
7	ANCHOR THREADED CONCRETE 1/4" X 1 3/4"	2500052	36
8	CONNECTOR CDMPRESSION #2/0 CU TD #2/0 CU	7213156	34
9	NUT 1/2" CLAMPING C/W SPRING NUT	2520004	12
10	BOLTED PARALLEL GROOVE GROUND CLAMP	7214105	12
11	WASHER LOCK 1/2" GALV	2530116	12
12	BOLT MACHINE 1/2" X 2" C/W HEX HEAD & NUT	2510330	12
13	WASHER GALV SQUARE 1 1/2" X 1 1/2" C/W 9/16" HOLE	2530001	12
14	CONNECTOR STIRRUP GROUNDING	7251095	2
15	CONNECTOR CU U BOLT CLAMP 250-500 kcmil STR	7214413	4

* QUANTITY IS BASED ON CABLE CHAMBER SIZE 3500 mm X 4000 mm

DISTRIBUTION CONSTRUCTION STANDARD
Grounding



Approved By:
E.M. 2017-03-31

Drafted By:
B.W.

Designed By:
E.H.

Original Issue:
C.P. 2001-01-10

Scale:
N.T.S.

Rev:
4

18-5100

2/2

UNDERGROUND SYSTEM
CABLE CHAMBER GROUNDING



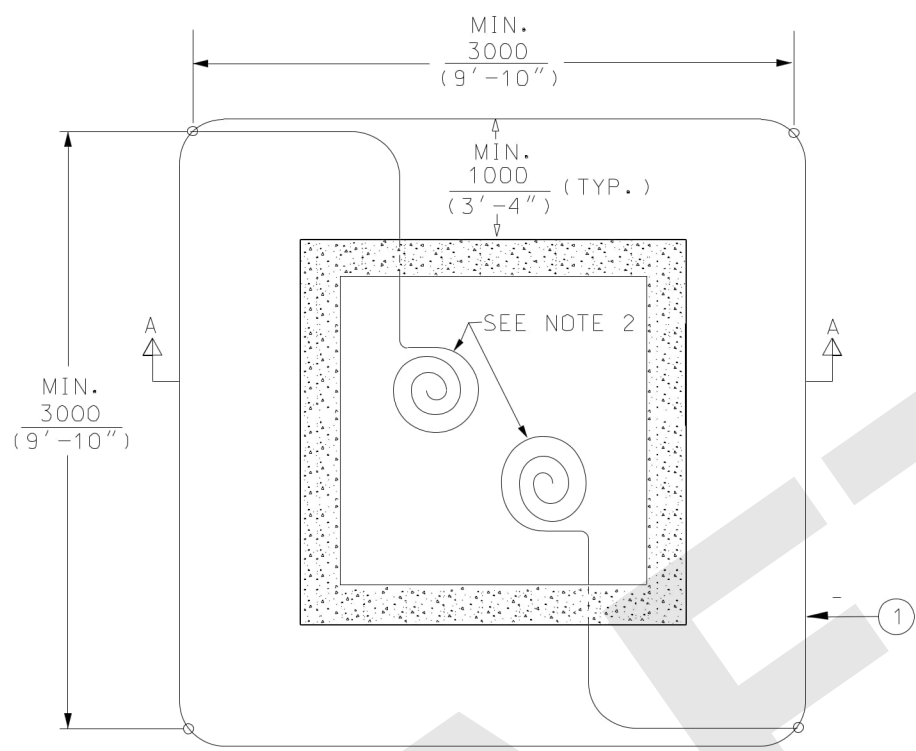

PLAN VIEW

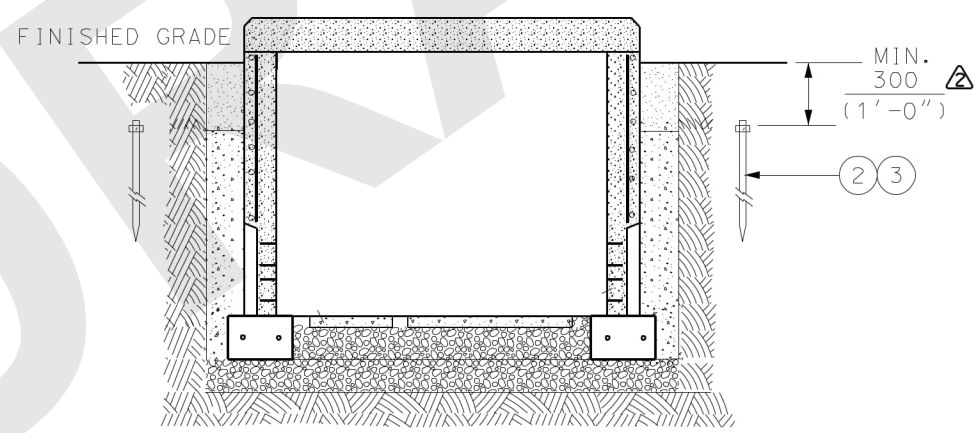

SECTION A-A

NOTES:

- 1) GROUNDING SHALL BE INSTALLED AS SHOWN. RODS TO BE CONNECTED BY 2/0 BARE COPPER TO FORM A COMPLETE GROUND LOOP AROUND FOUNDATION.
- 2) LEAVE TWO COILS EACH 2000 mm (6'-7") INSIDE EACH FOUNDATION.

DISTRIBUTION CONSTRUCTION STANDARD		GROUND GRID			
Grounding		PAD-MOUNTED EQUIPMENT			
	Approved By:				
	V. B. 2019-05-27				
Drafted By:	Designed By:	Original Issue:	Scale:	Rev:	
N. H.	V. B.	K. S. 2012-08-30	N. T. S.	2	18-5500
					1/3

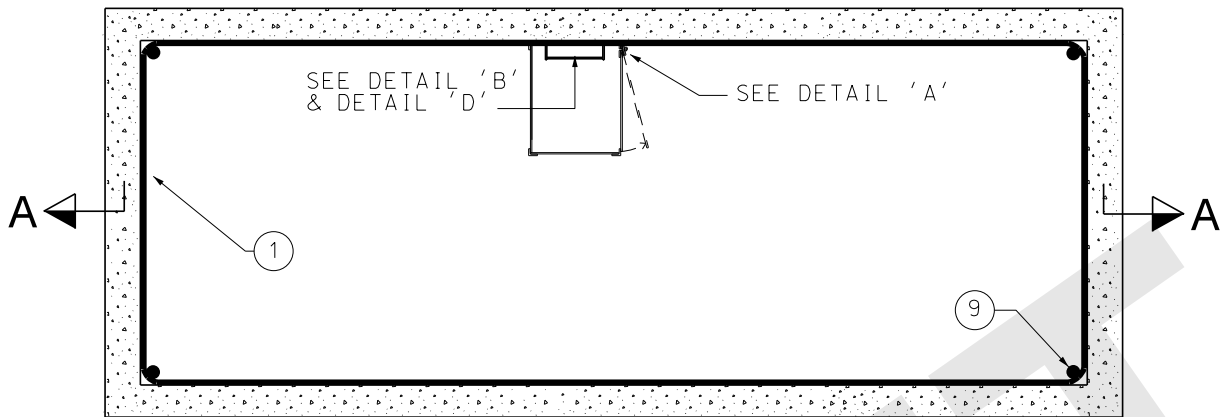

VAULT PLAN VIEW

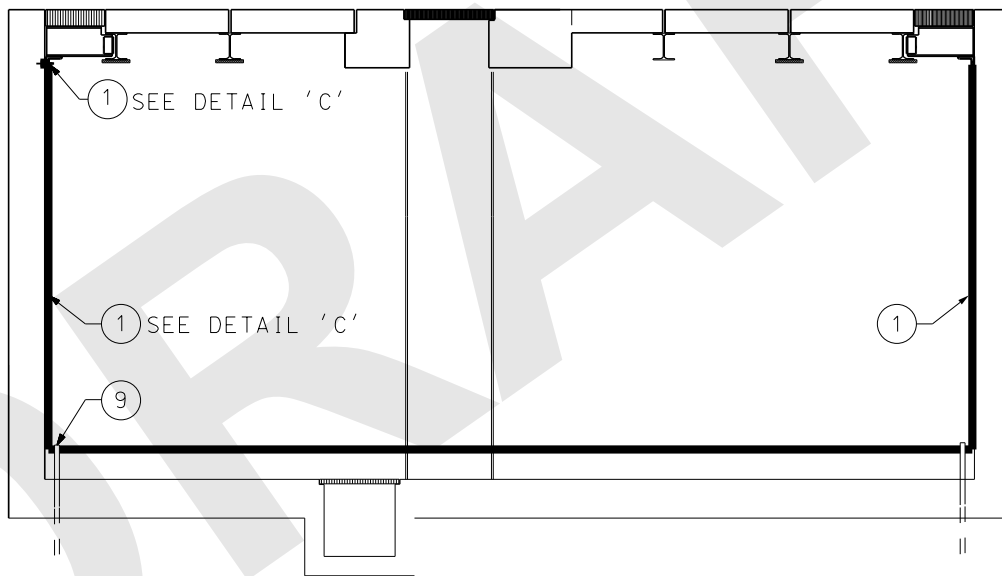

SECTION A-A

NOTES:

- 1) ALL MATERIAL IS GALVANIZED IN ACCORDANCE WITH LATEST CSA STANDARD G-164 EXCEPT HINGES WHICH ARE STAINLESS STEEL.
- 2) LOCATION OF LADDER AND DOOR SHALL BE DETERMINED AS PER CONSTRUCTION DRAWING.
- 3) DRILL $\frac{3}{8}$ " HOLE, INSTALL $\frac{3}{8}$ " BOLT (2510237), NUT (2530035), AND WASHER (2530127) CONNECT 2/0 BARE CU BOLT.

DISTRIBUTION CONSTRUCTION STANDARD
Grounding

**UNDERGROUND SYSTEM
TRANSFORMER VAULT
HATCHWAY FRAME & LADDER**



Approved By:

T. T. 2013-02-15

Drafted By:

A. M. E

Designed By:

I. E.

Original Issue:

K. S. / J. D. 2010-07-08

Scale:

N. T. S.

Rev:

2

18-5300

1/3

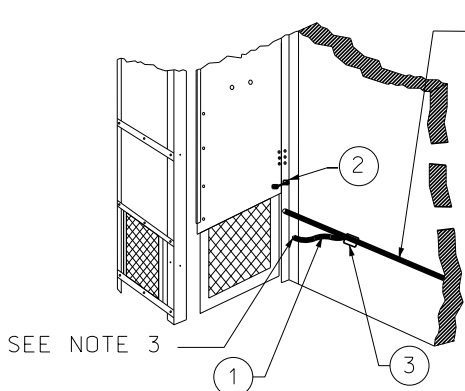

DETAIL 'A'
ISOMETRIC VIEW

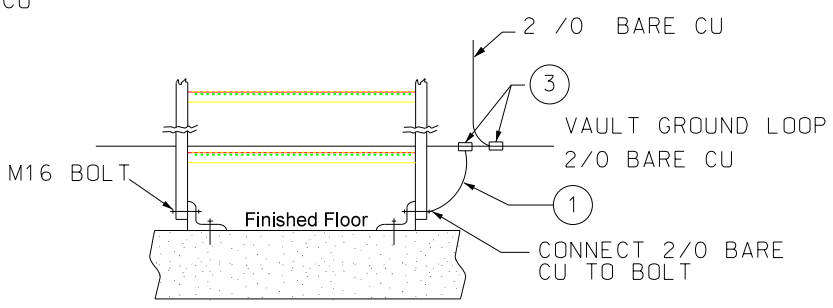

DETAIL 'B'
LADDERS ANCHORED BY BRACKET

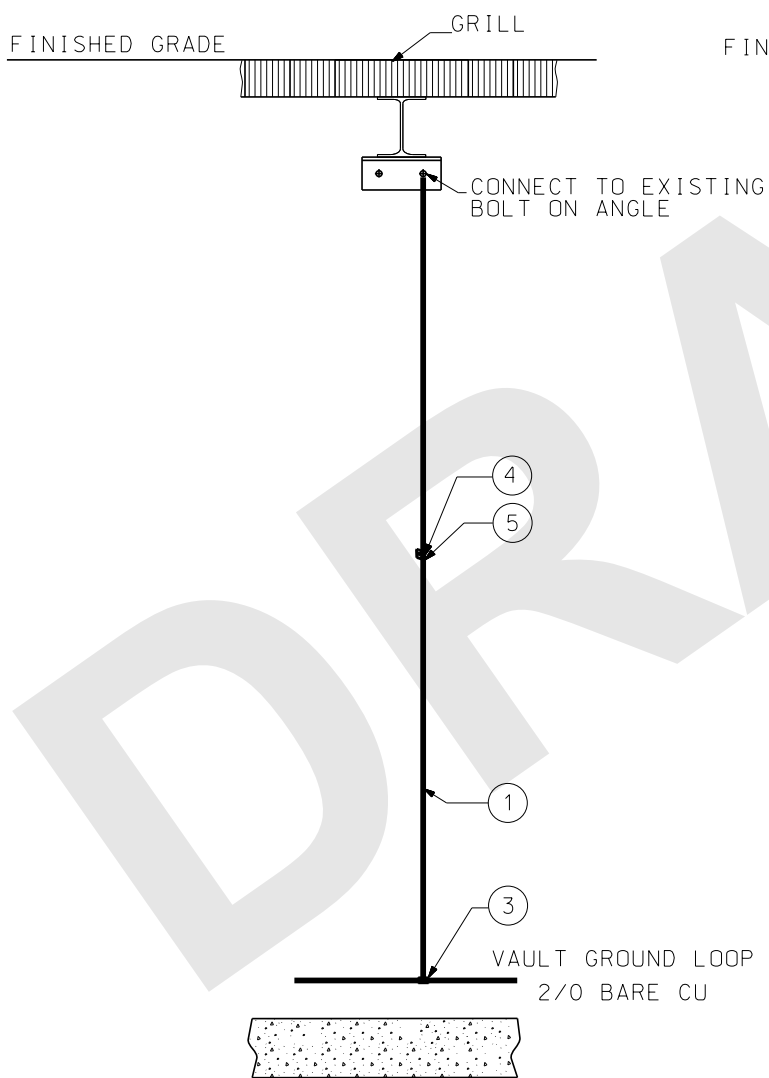

DETAIL 'C'
BEAM ANGLE

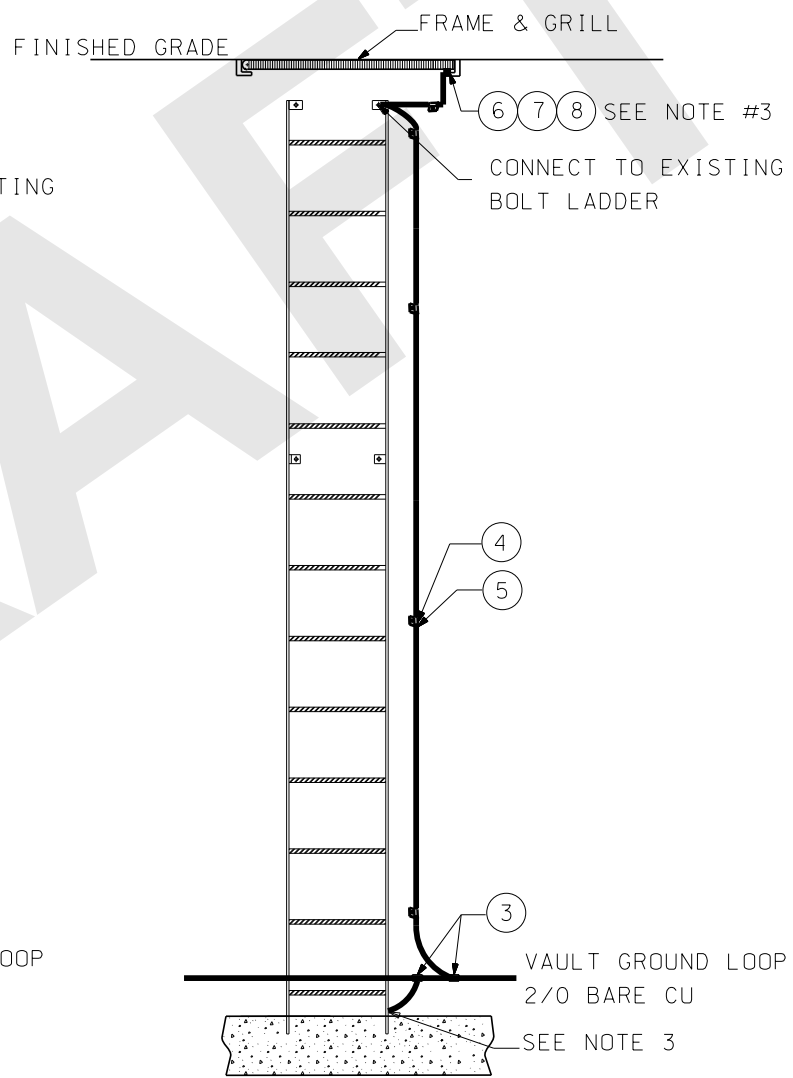

DETAIL 'D'
LADDERS EMBEDDED IN CONCRETE

DISTRIBUTION CONSTRUCTION STANDARD
Grounding

**UNDERGROUND SYSTEM
TRANSFORMER VAULT
HATCHWAY FRAME & LADDER**

	Approved By:		Original Issue:		Scale:	Rev:	18-5300	2/3
	T. T.	2013-02-15	K. S. / J. D.	2010-07-08				
	Drafted By:	Designed By:						
	A. M. E.	I. E.						



BILL OF MATERIALS FOR 18-5300

ITEM NO.	DESCRIPTION	ITEM I.D.	QTY
1	WIRE 2/0 19 STR CU SD	7105160	20
2	GROUND STRAP FLAT BRAID C/W U-BOLT	9650096	1
3	CONNECTOR CU PARALLEL GROOVE COMPRESSION	7213156	8
4	CLIP CABLE CSA-CONDUCTOR MOUNTING HARDWARE	7210190	20
5	ANCHOR THREADED CONCRETE 1/4" X 1 3/4"	2500052	20
6	BOLT MACHINE 3/8" X 1 1/2" BLACK IRON	2510237	3
7	WASHER STAINLESS STEEL 3/8"	2530035	3
8	WASHER LOCK 3/8" STAINLESS STEEL	2530127	3
9	ROD 3/4" X 10' GROUND STEEL GALVANIZED	2470102	4

DISTRIBUTION CONSTRUCTION STANDARD
Grounding

UNDERGROUND SYSTEM
TRANSFORMER VAULT
HATCHWAY FRAME & LADDER



Approved By:

T. T. 2013-02-15

Drafted By:

A. M. E

Designed By:

I. E.

Original Issue:

K. S. / J. D. 2010-07-08

Scale:

N. T. S.

Rev:

2

18-5300

3/3

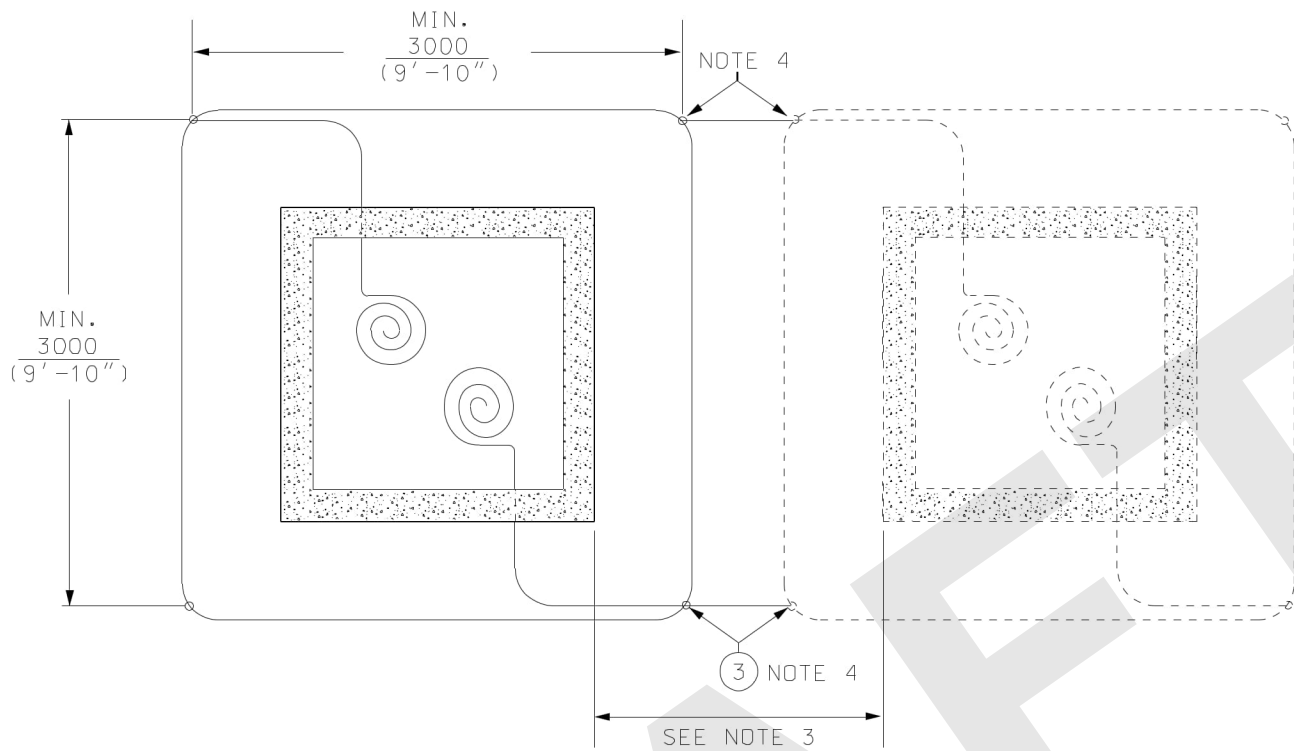

PLAN VIEW ⚠

BONDING OF ADJACENT GROUND GRIDS
SEPARATED BY LESS THAN 5 m

NOTES: ⚠

- 3) IF SEPARATION TO ANOTHER STRUCTURE IS LESS THAN 5 m, GROUNDING GRIDS SHALL BE BONDED.
- 4) IF GROUND GRIDS OVERLAP, GROUND RODS MAY BE SHARED BETWEEN GRIDS.

DISTRIBUTION CONSTRUCTION STANDARD
Grounding

**GROUND GRID
PAD-MOUNTED EQUIPMENT**



Approved By:
V.B. 2019-05-27
Drafted By:
N.H. Designed By:
V.B.

Original Issue:
K.S. 2012-08-30

Scale:
N.T.S.

Rev: **2**

18-5500



2/3



BOM LEGEND	
A	SINGLE GROUND GRID
B	SINGLE GROUND GRID WITH SEPARATION LESS THAN 5 m

BILL OF MATERIALS FOR 18-5500				
ITEM NO.	DESCRIPTION	ITEM I.D.	QTY	
			A	B
1	WIRE 2/0 19 STR CU SD	7105160	24	34
2	ROD 3/4" X 10' GROUND STEEL GALVANIZED	2470102	4	4
3	CONNECTOR CU GROUND WRENCH LOCK 3/4" ROD TO 2/0 CU CONDUCTOR	7214200	6	10
ASSOCIATED STANDARDS				
4	GROUND ROD INSTALLATION	STD. 18-4300	1	1



DRAFT

DISTRIBUTION CONSTRUCTION STANDARD
Grounding

**GROUND GRID
PAD-MOUNTED EQUIPMENT**



Approved By:
V.B. 2019-05-27

Drafted By: N.H.
Designed By: V.B.

Original Issue:
K.S. 2012-08-30

Scale:
N.T.S.

Rev: **2**

18-5500

3/3



**MINIMUM UNDERGROUND CLEARANCES AS PER CITY OF TORONTO MCR
(EDGE TO EDGE)**

Utilities or Plant		Vertical mm (feet)	Horizontal mm (feet)	
Railways	Heavy Rail (CN/CP/GO)	Refer to STD. 31-1310		
	Light Rail (TTC/LRT/Metrolinx)	Refer to STD. 31-1200		
Hydro One	All Infrastructure	1000 (3'-4")	1000 (3'-4")	
Communication	Bell Canada	Manholes	1000 (3'-4")	
		Concrete Encased Ducts	600 (2'-0")	
		Direct Buried Ducts	300 (1'-0")	
	Others	All Infrastructure	300 (1'-0")	600 (2'-0")
Enwave Energy Corporation	Steam Pipes	600 (2'-0")	600 (2'-0")	
	Chilled Water Pipes	300 (1'-0")	300 (1'-0")	
Enbridge Gas National Energy Board	≤ NPS 300 mm (12") (Open Trench)	300 (1'-0")	600 (2'-0")	
	CER Regulated Pipelines and Vital Mains (Open Trench)	600 (2'-0")	1000 (3'-4")	
	ALL Pipelines Directional Drilling/Boring	1000 (3'-4")	1000 (3'-4")	
	Regulator Stations	Consult with City	1000 (3'-4")	
City of Toronto	Trees		See Note 1 and Std. 31-0400	
	Catch Basins		Consult with City	500 (1'-8")
	Traffic Signal Ducts		300 (1'-0")	600 (2'-0")
	Storm Sewer	< 150 (6") Dia.	150 (6")	600 (2'-0")
		150 (6") < 750 (2'-6") Dia.	300 (1'-0")	750 (2'-6")
		≥ 750 (2'-6") Dia.	500 (1'-8")	900 (3'-0")
		Maintenance Hole		-
	Sanitary/ Combined Sewer	< 100 (4") Dia.	150 (6")	600 (2'-0")
		100 (4") < 375 (1'-3") Dia.	300 (1'-0")	750 (2'-6")
		≥ 375 (1'-3") Dia.	500 (1'-8")	900 (3'-0")
		Maintenance Hole		-
	Water Mains	< 100 (4") Dia.	150 (6")	600 (2'-0")
		≥ 100 (4") < 400 (1'-4") Dia.	300 (1'-0")	750 (2'-6")
		≥ 400 (1'-4") Dia.	500 (1'-8")	900 (3'-0")
		Water Valve Chamber		See Note 5
	Fire Hydrant		400 (1'-4")	1500 (4'-11")
Toronto Hydro (This to be used when other Utilities are installing their plant close to THESL infrastructure)	Poles (Direct Buried)		See Std's. 03-2400, 04-4100 and 04-5100	
	Base Mounted Poles/ Reinforced Sidewalk Bays		See Note 3	
	Cable Chamber/Vault/Tap Boxes (No Grounding Outside Structures)		-	600 (2'-0")
	Padmounts/Sub Vaults/Splice Vaults (Grounding Outside Structure)		Refer to STD. 31-4100	
	Ducts/Duct Banks		300 (1'-0")	600 (2'-0")

DISTRIBUTION CONSTRUCTION STANDARD
Civil Construction

UNDERGROUND CLEARANCES

	Approved by:		Original issue: J.D. 2000-12-28	Scale: N.T.S.	Rev. 9	31-0100	1/2
	Drafted by: J.D.	Designed by: B.D.					

Notes:

1. Any construction activity in the vicinity of trees shall be carried out in compliance with latest City of Toronto's "Tree Protection Policy and Specification for Construction Near Trees" document.
2. If the minimum clearances shown cannot be met, the subject utilities approval may be obtained for reduced clearances.
3. Horizontal clearance shall be from edge of reinforced sidewalk bay or pole base to edge of proposed plant. Contractor shall at no time cut into reinforced sidewalk bays and pole bases. Sidewalk bays and pole bases provide loading support for the pole. Plant can be installed under reinforced sidewalk bays by tunneling at a minimum vertical clearance of 600 mm (2'-0"). Plant shall not be installed under pole bases.
- △ 4. If the minimum horizontal clearance for utilities installing plant close to THESL plant cannot be met due to existing field conditions, clearance can be reduced to 300mm (1'-0") with the Contractor/Customer providing the reasons for the reduced clearance. Approvals can be provided by Toronto Hydro Standards Department for reduced clearance.
- △ 5. Any proposed horizontal clearance less than 300 mm (1'-0") will require an ESA deviation with the following supporting documentation:
 - a) A letter stamped and signed by a Professional Engineer of Ontario, outlining:
 - That the Contractor/Customer is responsible for all costs associated with support and inspection, as well as any damages and associated costs;
 - The method of protection and/or support. Support is required if Toronto Hydro plant is undermined;
 - That this is a unique scenario that requires a deviation from typical construction standard, and identify that the deviation is also from the typical clearances set out by Toronto Hydro and the City of Toronto.
 - b) Drawing which shall include:
 - Stamp and signature of a Professional Engineer in the Province of Ontario;
 - Length of the plant being supported and/or protected;
 - Method of protection and/or support system in both plan and section views;
 - Maximum deflection of the plant with the support;
 - Deflection monitoring system placement if soil settlement will occur on site;
 - Backfilling procedures.
6. Contact the City of Toronto for minimum vertical clearance to water valve chamber.
7. For above grade clearance refer to:
 - 03-2300 Building and Permanent Structures
 - 03-2400 Poles and Private Fences
 - 04-4100 Pole Location Guidelines

DISTRIBUTION CONSTRUCTION STANDARD Civil Construction		UNDERGROUND CLEARANCES				
	Approved by:		Original issue: J.D. 2000-12-28	Scale: N.T.S.	Rev. 9	31-0100
	Drafted by: J.D.	Designed by: B.D.				

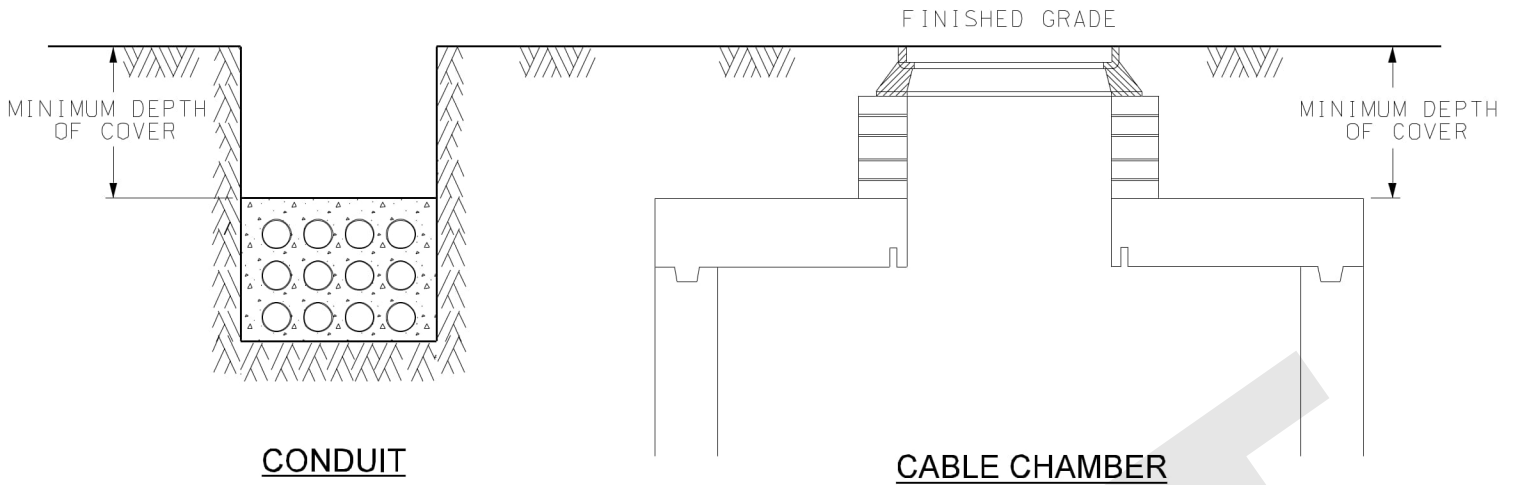

THE "MINIMUM DEPTH OF COVER" FOR THESE PLANT (CONDUITS AND CABLE CHAMBERS) SHALL BE AS FOLLOWS:

TYPE	MINIMUM DEPTH OF COVER	DESCRIPTION
CURBED ROADS	1000 (3'-4")	FOR AREAS UNDER THE ROAD, CURB, AND SIDEWALK, THE PORTION OF THE BOULEVARD WITHIN ONE METRE OF THE BACK OF CURB AND/OR SIDEWALK, AND THE ENTIRE RIGHT-OF-WAY WITHIN 30 METRES OF AN INTERSECTION, THE MINIMUM DEPTH OF COVER SHALL BE ONE METRE.
UNCURBED ROADS	1300 (4'-3") BELOW THE CENTERLINE OF THE ROAD, OR 600 (2'-0") BELOW THE LOWEST POINT OF THE ADJACENT DITCH, WHICHEVER IS DEEPER.	FOR THE ENTIRE RIGHT-OF-WAY, FROM STREET-LINE TO STREET-LINE, ON UNCURBED ROADS.
BOULEVARDS	800 (2'-8")	EXCEPT WHERE SPECIFIED ABOVE, THE MINIMUM DEPTH OF COVER ON ALL STREETS SHALL BE 800 MILLIMETRES.

- NOTES:**
- 1) THE DEPTHS OF COVER ARE IN ACCORDANCE WITH THE CITY'S MUNICIPAL CONSENT REQUIREMENTS DOCUMENT.
 - 2) THE DEPTHS OF COVER APPLY TO ALL CONDUITS IRRESPECTIVE OF THE TYPE AND METHOD OF INSTALLATION.

DISTRIBUTION CONSTRUCTION STANDARD
Civil Construction



Approved By:
B.D. 2018-08-29

Drafted By: M.D. Designed By: B.D.

Original Issue:
J.D. 2010-10-21

**UNDERGROUND CLEARANCES
MINIMUM DEPTH OF COVER
FOR TORONTO HYDRO STRUCTURES**

Scale: N.T.S. Rev: **2** **31-0300** **1/1**

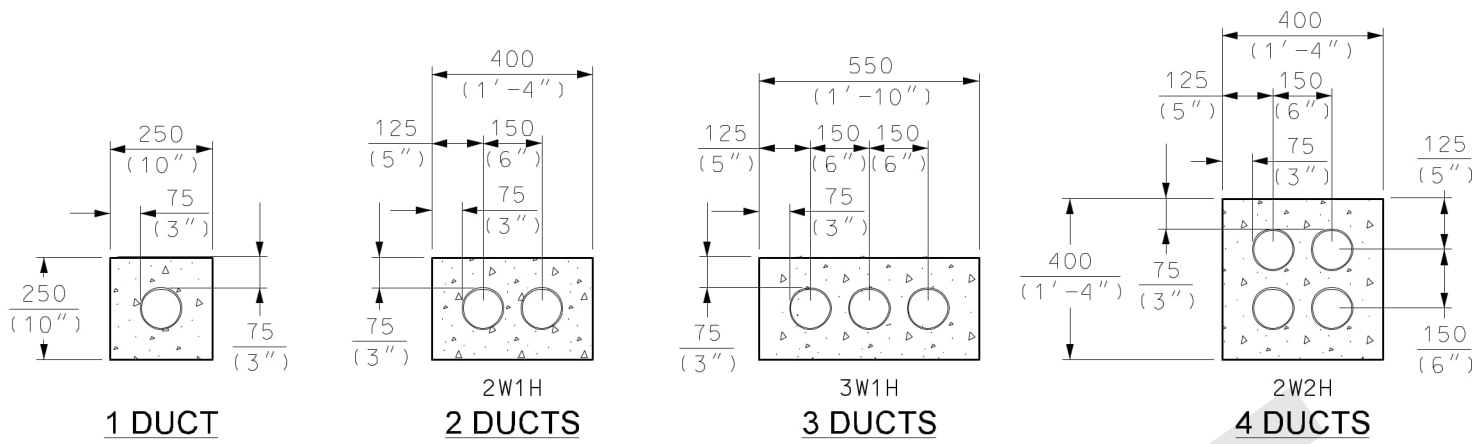

1 DUCT

**2W1H
2 DUCTS**

**3W1H
3 DUCTS**

**2W2H
4 DUCTS**

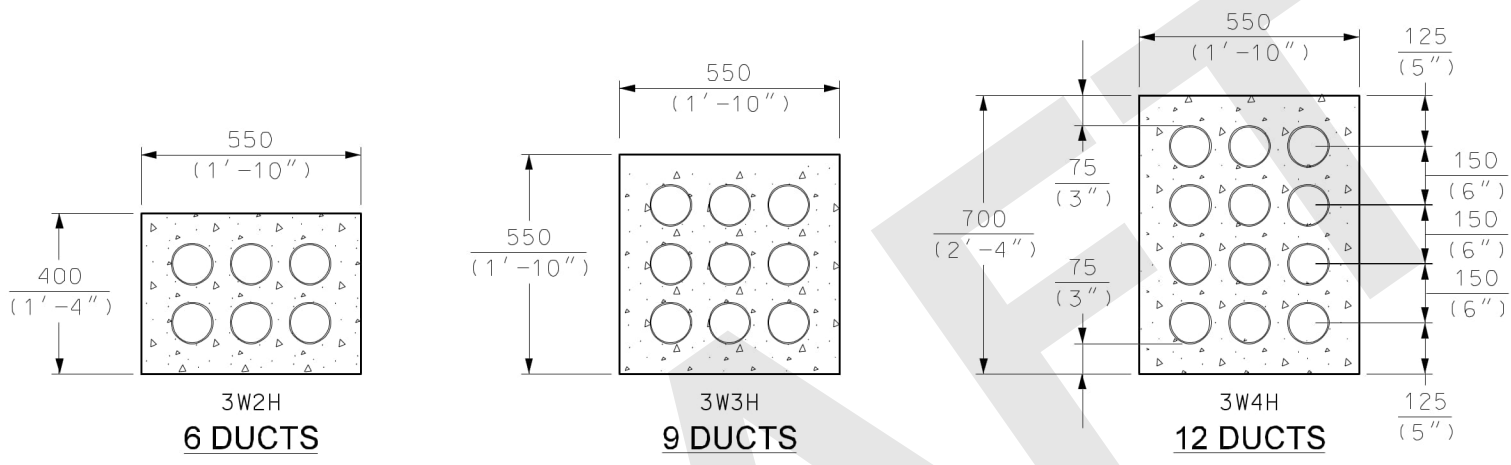

**3W2H
6 DUCTS**

**3W3H
9 DUCTS**

**3W4H
12 DUCTS**

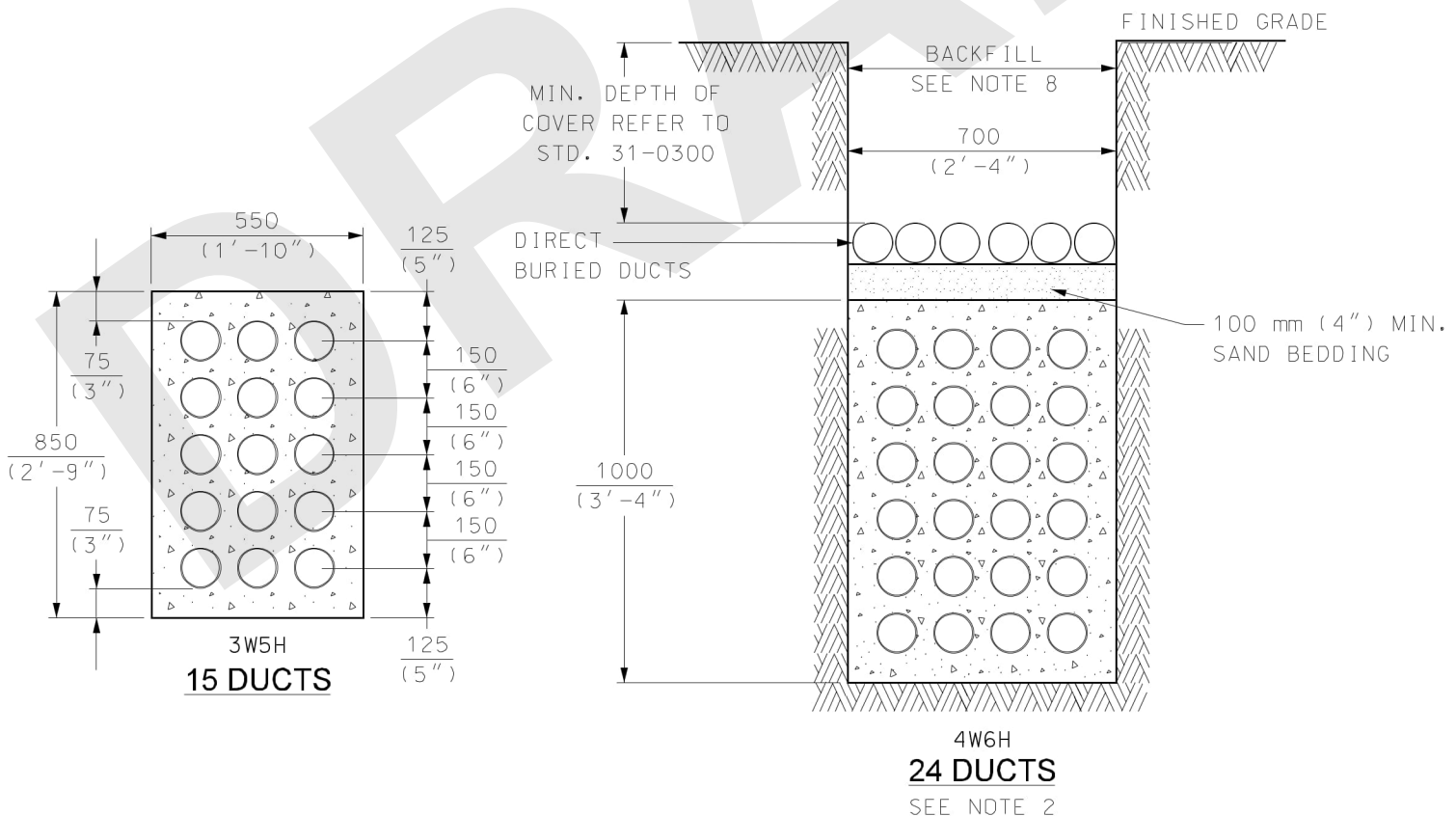

**4W6H
24 DUCTS**
SEE NOTE 2

DISTRIBUTION CONSTRUCTION STANDARD Civil Construction		CONDUITS				
Approved By: J.D. 2017-08-14		CONCRETE ENCASED AND DIRECT BURIED DUCTS				
	Drafted By: B.D.	Designed By: J.D.	Original Issue: G.D./C.P. 2002-07-11	Scale: N.T.S.	Rev: 8	31-1120
						1/2

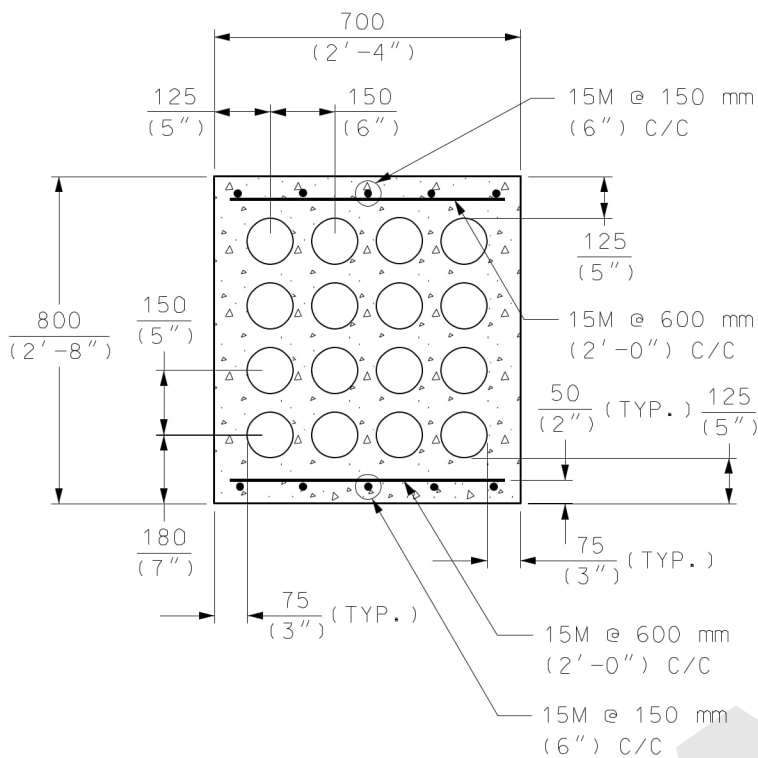

REINFORCED DUCT BANK

SEE NOTE 3

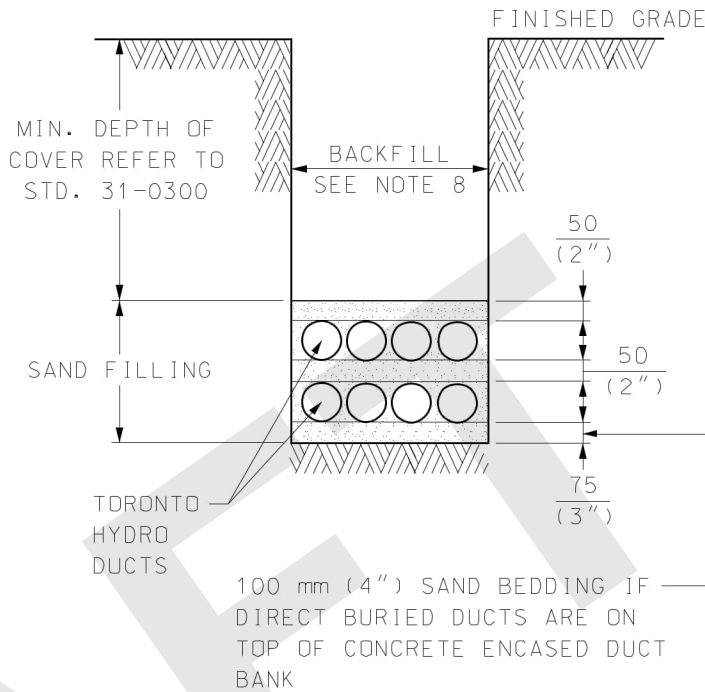

DIRECT BURIED DUCTS

SEE NOTES 2, 9 and 10

NOTES:

- 1) REFER TO STD. 31-0300 FOR MIN. DEPTH OF COVER.
- 2) IN AN OPEN TRENCH CONSTRUCTION, ENCASE THE DUCTS IN CONCRETE IF:
 - DUCTS ARE CARRYING PRIMARY CABLES (750 V OR MORE),
 - DUCTS ARE UNDER ROADWAY OR DRIVEWAY,
 - DUCT HAVE 90 DEGREE BENDS,
 - THE NUMBER OF DUCTS ARE MORE THAN 8.
 IF NONE OF THE ABOVE CATEGORY APPLIES, THEN THE DUCTS SHALL BE DIRECT BURIED.
- 3) REINFORCED DUCT BANK SHALL BE USED ONLY IN PDOR SOIL CONDITIONS OR WHERE THERE IS HIGH WATER TABLE.
- 4) CONCRETE SHALL BE A MIN. 20 MPa, WITH 10 mm (3/8") AGGREGATES.
- 5) REINFORCING SHALL CONFORM TO CSA STANDARD G30.18-09, Fy = 400 MPa.
- 6) ALL DUCTS SHALL BE 100 mm (4") IN DIAMETER UNLESS NOTED OTHERWISE.
- 7) HORIZONTAL AND VERTICAL SEPARATION BETWEEN DUCTS IS CONTROLLED DURING CONSTRUCTION BY PLASTIC DUCT SPACERS.
- 8) EXCAVATION SHALL BE BACKFILLED TO GRADE AS PER SPECIFICATION #CV-CON-01 CLAUSE 5.1.17 AND/OR TORONTO'S LATEST BACKFILLING REQUIREMENT.
- 9) MAX. NUMBER OF DIRECT BURIED DUCTS SHALL BE 8. DUCTS MAY BE PLACED IN AN IRREGULAR FORMATION IN A MAX. OF TWO ROWS.
- 10) RED DUCT SHALL BE USED IN ALL NEW AND REBUILD UNDERGROUND DIRECT BURIED INSTALLATIONS. THIS INCLUDES ELECTRICAL CABLES AND COMMUNICATION CABLES. IF REQUIRED, 50 mm (2") DUCT CAN BE USED FOR COMMUNICATION CABLES.

DISTRIBUTION CONSTRUCTION STANDARD
Civil Construction

CONDUITS

CONCRETE ENCASED AND DIRECT BURIED DUCTS



Approved By:
J.D. 2017-08-14

Drafted By: B.D.
Designed By: J.D.

Original Issue:
G.D./C.P. 2002-07-11

Scale:
N.T.S.

Rev:
8

31-1120

2/2

© CERTIFIED BY TORONTO HYDRO STANDARD <STANDARDS@TORONTOHYDRO.COM>; THIS DOCUMENT IS FOR USE BY TORONTO HYDRO AND AUTHORIZED PERSONS ONLY AS PER THE TERMS IN TORONTO HYDRO STANDARD 00-0002.

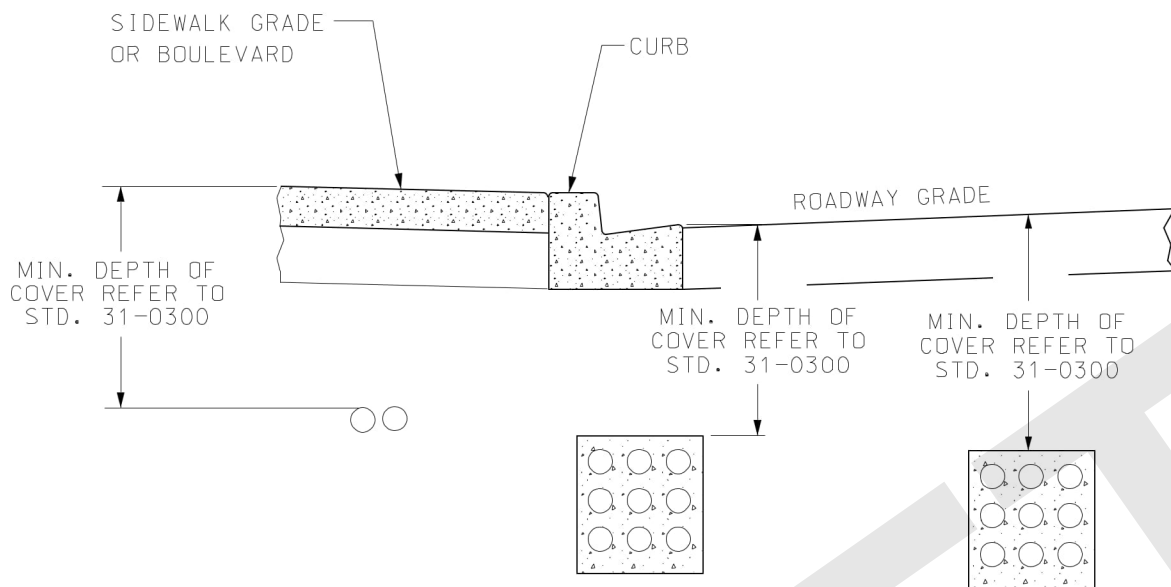

DETAIL "A" ⚠

NOTE: THIS ALSO APPLIES TO DIRECT BURIED DUCTS AND POLYPIPES

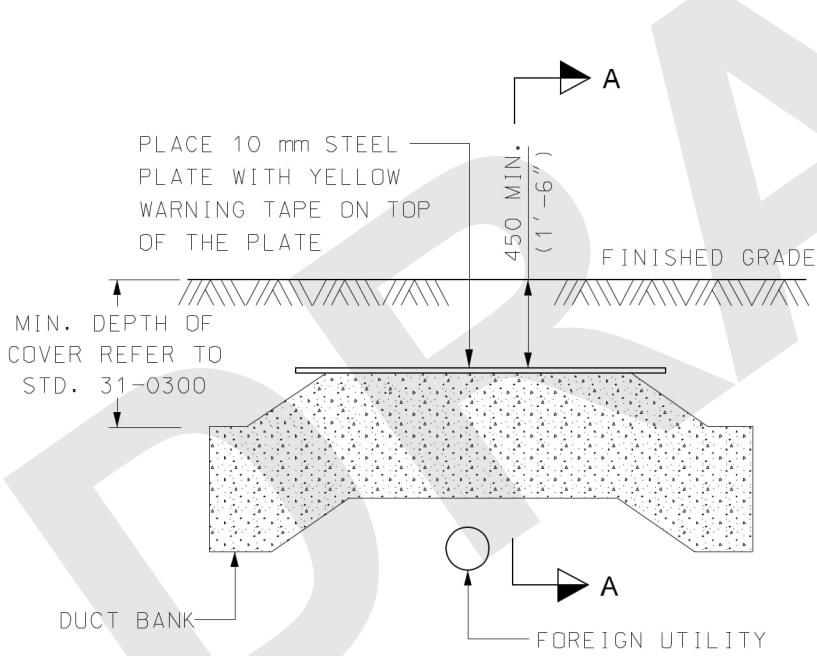

DETAIL "B" ⚠
REDUCED DEPTH OF COVER

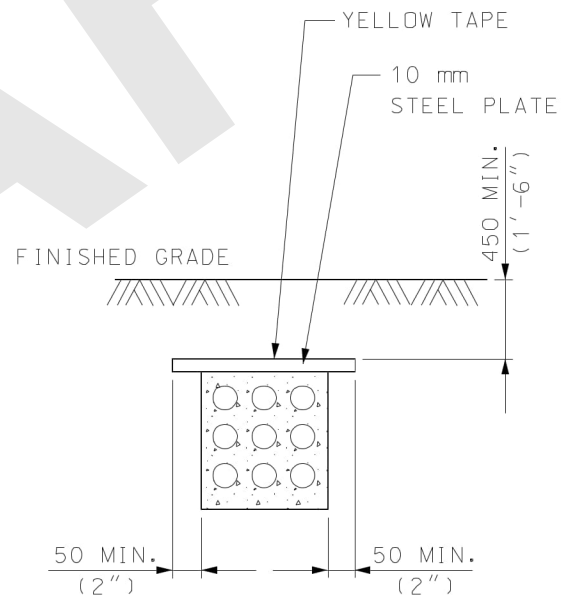

SECTION A-A ⚠

NOTES: ⚠

- 1) IF UNDER SPECIFIC CIRCUMSTANCES MINIMUM DEPTH OF COVER REQUIREMENT CANNOT BE MET, REDUCED COVER MAY BE USED WITH CITY'S APPROVAL. THE REDUCED COVER SHALL NOT BE LESS THAN 450 mm (1'-6").
- 2) IF MINIMUM DEPTH OF COVER IS REDUCED, A 10 mm STEEL PLATE AND WARNING TAPE HAS TO BE PROVIDED AS SHOWN IN DETAIL "B".

DISTRIBUTION CONSTRUCTION STANDARD
Civil Construction

**CONDUITS
DEPTH OF CONDUITS**

	Approved By: B.D. 2018-08-31		Original Issue: G.D. /L.G. 2000-12-19	Scale: N.T.S.	Rev: 6	31-1150	1/1
	Drafted By: B.D.	Designed By: B.D.					

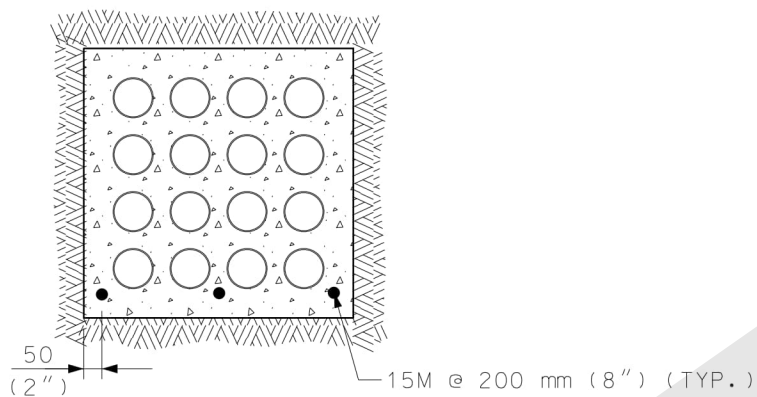

TYPICAL CROSS SECTION.

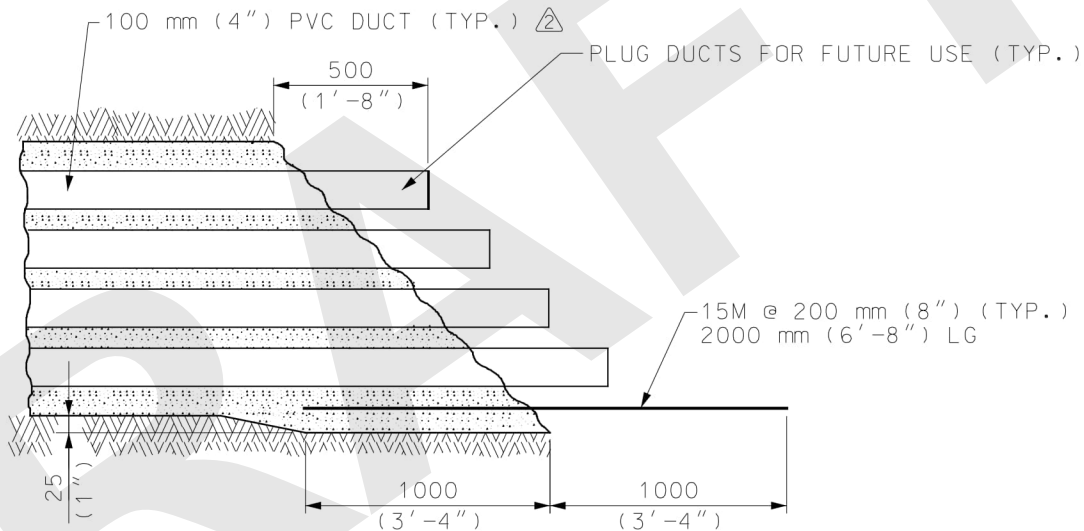

CAPPING PROPOSED DUCTS FOR FUTURE EXTENSION

NOTES:

- 1) ALL REINFORCEMENT TO BE 15M BARS.
- 2) PROPOSED DUCTS TO BE STEPPED TO ACCOMODATE FUTURE CONNECTION. REINFORCEMENT TO BE INSTALLED AS SHOWN.
- 3) AT GRADE LEVEL, CONTRACTOR TO INDICATE TERMINATION POINT OF DUCT;
 - A) ON PRIVATE PROPERTY USE STAKE.
 - B) WITHIN CITY ALLOWANCE USE A METAL PLATE WITH RAISED LETTERS "TORONTO HYDRO MARKER". REFER TO STD. 31-8100 FOR DETAILS.

DISTRIBUTION CONSTRUCTION STANDARD
Civil Construction

CONDUITS
CAPPING PROPOSED DUCTS FOR FUTURE EXTENSION



Approved By:
J.D. 2012-11-08

Drafted By: D.L.
Designed By: J.D.

Original Issue:
L.G. 2000-12-30

Scale:
N.T.S.

Rev: **2**

31-1160

1/1

© CERTIFIED BY TORONTO HYDRO STANDARD <STANDARDS@TORONTOHYDRO.COM>; THIS DOCUMENT IS FOR USE BY TORONTO HYDRO AND AUTHORIZED PERSONS ONLY AS PER THE TERMS IN TORONTO HYDRO STANDARD 00-0002.

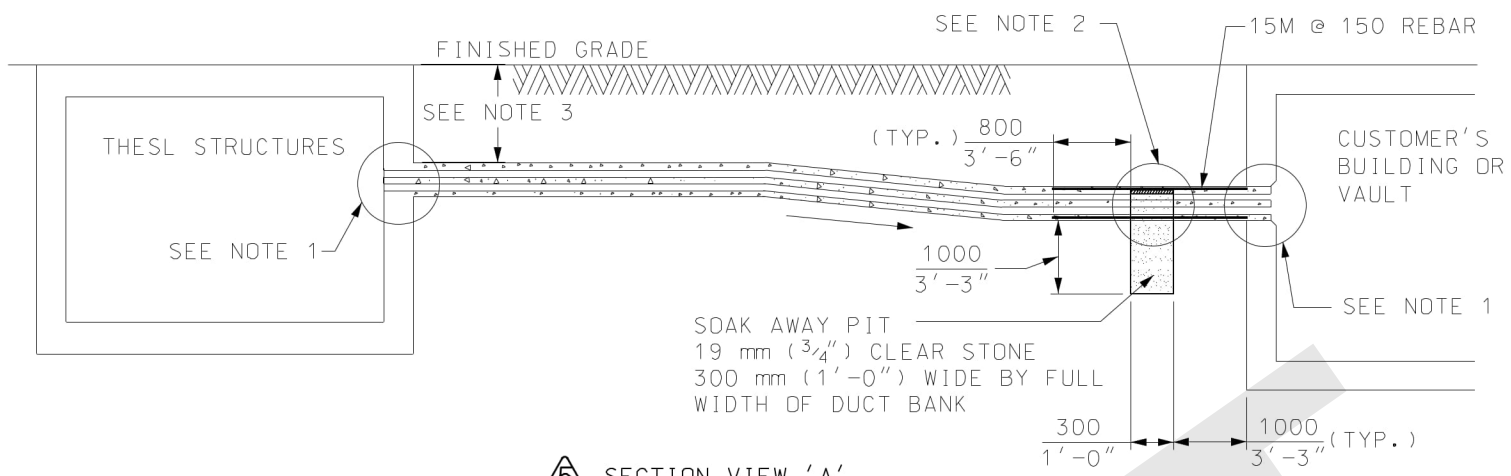

SECTION VIEW 'A'

DUCTS FROM THESL STRUCTURES TO CUSTOMER'S BUILDING/VAULT

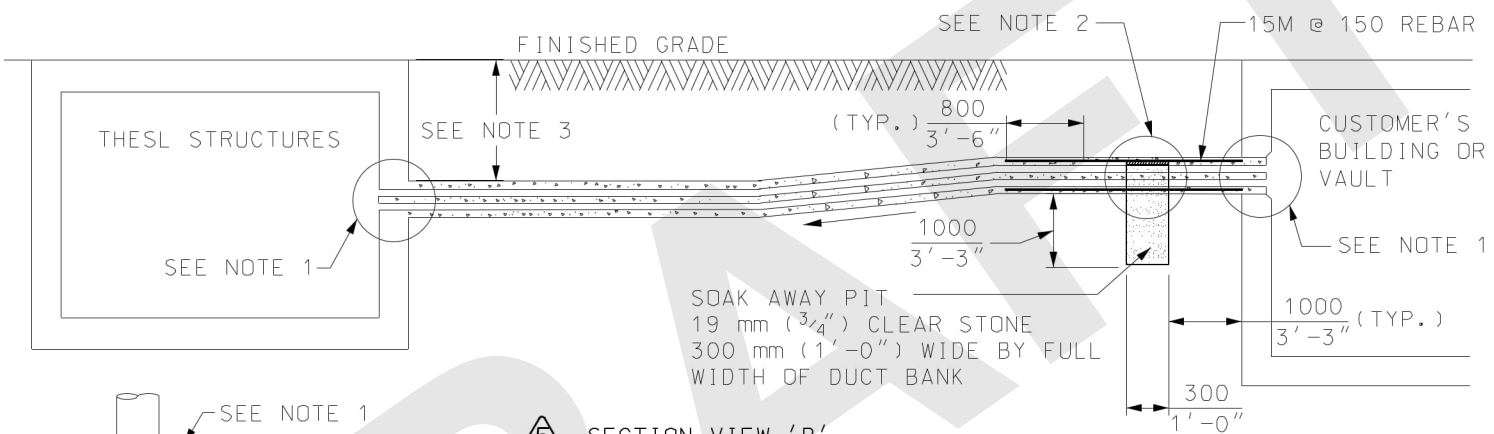

SECTION VIEW 'B'

DUCTS FROM THESL STRUCTURES TO CUSTOMER'S BUILDING/VAULT

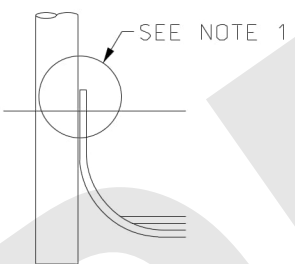

SECTION VIEW 'C'

DUCTS FROM THESL POLES TO CUSTOMER'S BUILDING/VAULT

NOTES:

- 1) SEALANT SHALL BE APPLIED TO:
 - DUCTS EXITING THESL STRUCTURES (POLES, CABLE CHAMBERS, PADMOUNTS, SPLICE VAULTS, TAP/SPLICE BOXES AND VAULTS) WHEN FEEDING INTO CUSTOMER'S BUILDING/VAULTS AND ALSO DUCTS AT CUSTOMER'S BUILDING/VAULTS ENTRANCE POINT;
 - LOCATIONS WHERE EXISTING SEALANT (STOCK CODES 8940011, 9656790 OR 9656791) IS NOT ADEQUATE.
- 2) DRILL 4 DRAINAGE HOLES IN THE BOTTOM OF EACH DUCT. 13 mm (1/2") DIA. AT 50 mm (2") CENTRES. FILL TO TOP OF DUCTS WITH 19 mm (3/4") CLEAR STONE, TOP OFF WITH A LAYER OF 25 mm (1") STYROFOAM, AND A FINAL LAYER OF CONCRETE.
- 3) REFER TO STD. 31-0300 FOR MIN. DEPTH OF COVER.
- 4) CUSTOMER IS RESPONSIBLE TO CONSTRUCT SOAKAWAY PIT ON CUSTOMER PROPERTY AS INDICATED ABOVE.

DISTRIBUTION CONSTRUCTION STANDARD
Civil Construction

**CONDUITS
SUPPLYING CUSTOMER'S BUILDING**



Approved By: **2021/10/21**

Drafted By: J.D. Designed By: B.D.

Original Issue: G.D./C.P. 2002-11-25

Scale: N.T.S. Rev: **5** **31-1230** **1/1**

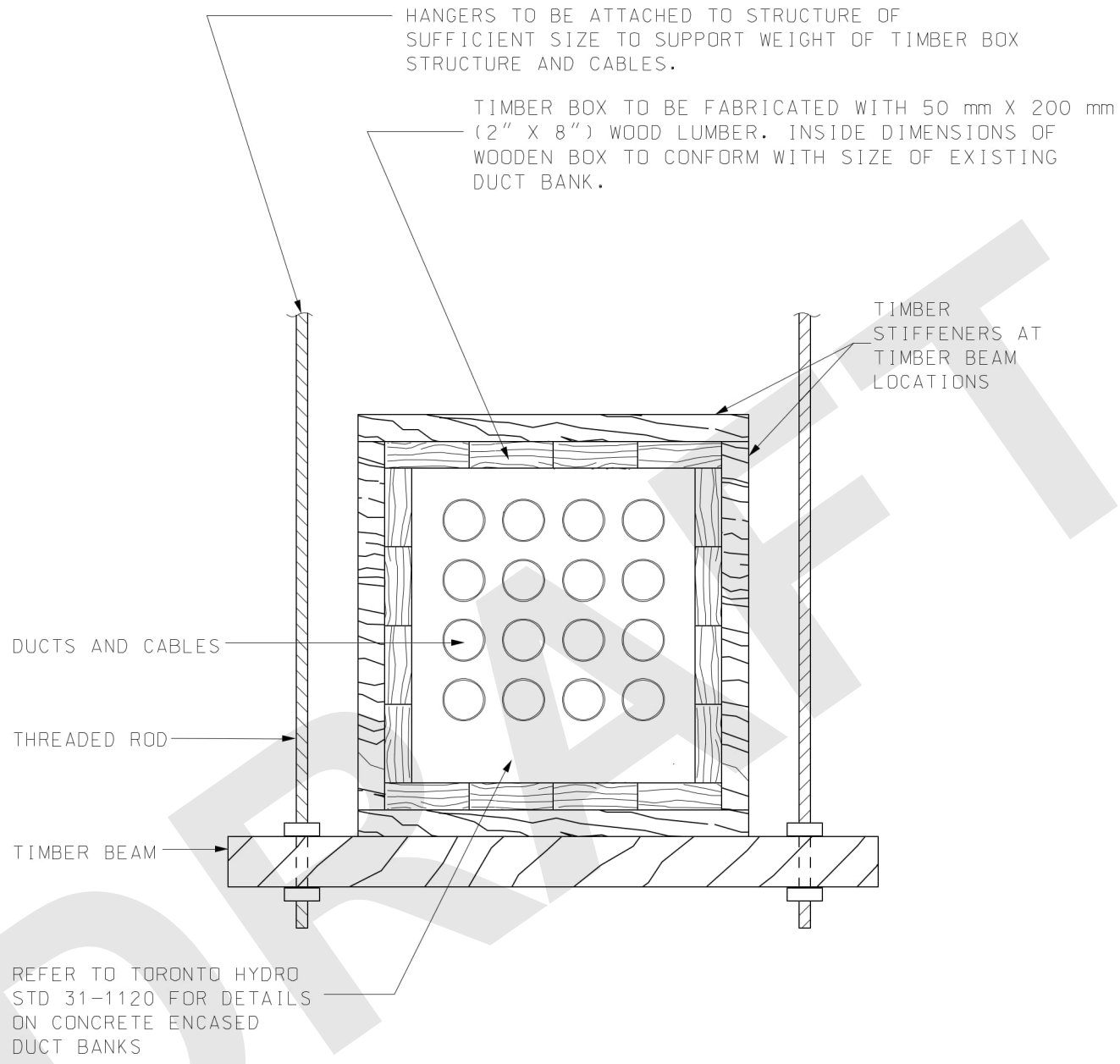

**CONCRETE ENCASED DUCTS
TIMBER BOX DETAIL**

DISTRIBUTION CONSTRUCTION STANDARD Civil Construction		DUCT OR CABLE SUPPORT IN PLACE SYSTEM				
Approved By:				Scale:	Rev:	
	Drafted By: B.D.	Designed By: J.D.	Original Issue: G.D./C.P. 2002-11-25	N.T.S.	3	
					31-1350	
					1/4	

© CERTIFIED BY TORONTO HYDRO STANDARD <STANDARDS@TORONTOHYDRO.COM>, THIS DOCUMENT IS FOR USE BY TORONTO HYDRO AND AUTHORIZED PERSONS ONLY AS PER THE TERMS IN TORONTO HYDRO STANDARD 00-0002.

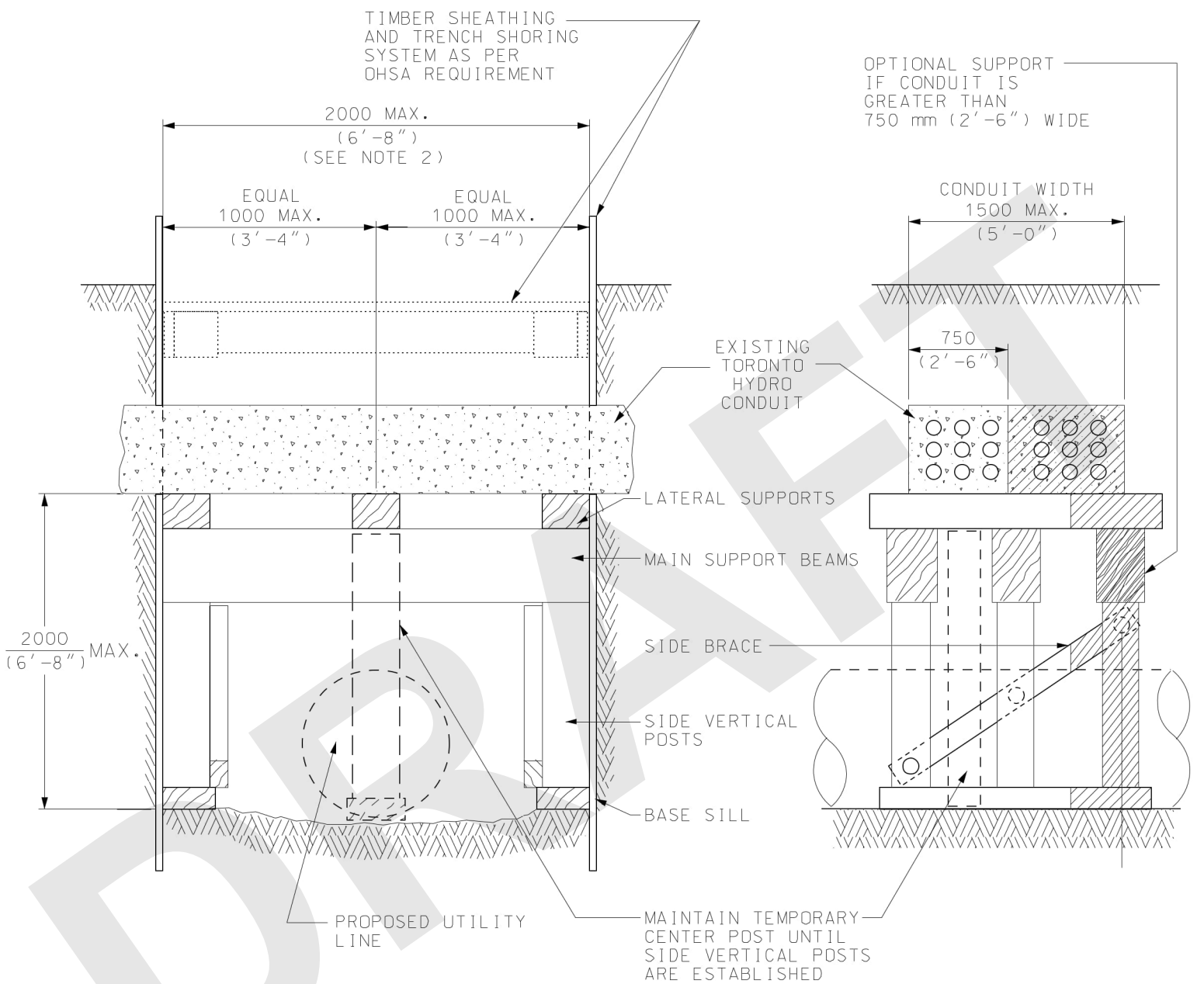

**CONCRETE ENCASED DUCTS
SUPPORT FROM BELOW**

DISTRIBUTION CONSTRUCTION STANDARD
Civil Construction

**DUCT OR CABLE
SUPPORT IN PLACE SYSTEM**

	Approved By:		Original Issue:		Scale:	Rev:	3	31-1350	2/4
	Drafted By: B.D.	Designed By: J.D.	G.D./C.P. 2002-11-25		N.T.S.				

© CERTIFIED BY TORONTO HYDRO STANDARD <STANDARDS@TORONTOHYDRO.COM>; THIS DOCUMENT IS FOR USE BY TORONTO HYDRO AND AUTHORIZED PERSONS ONLY AS PER THE TERMS IN TORONTO HYDRO STANDARD 00-0002.

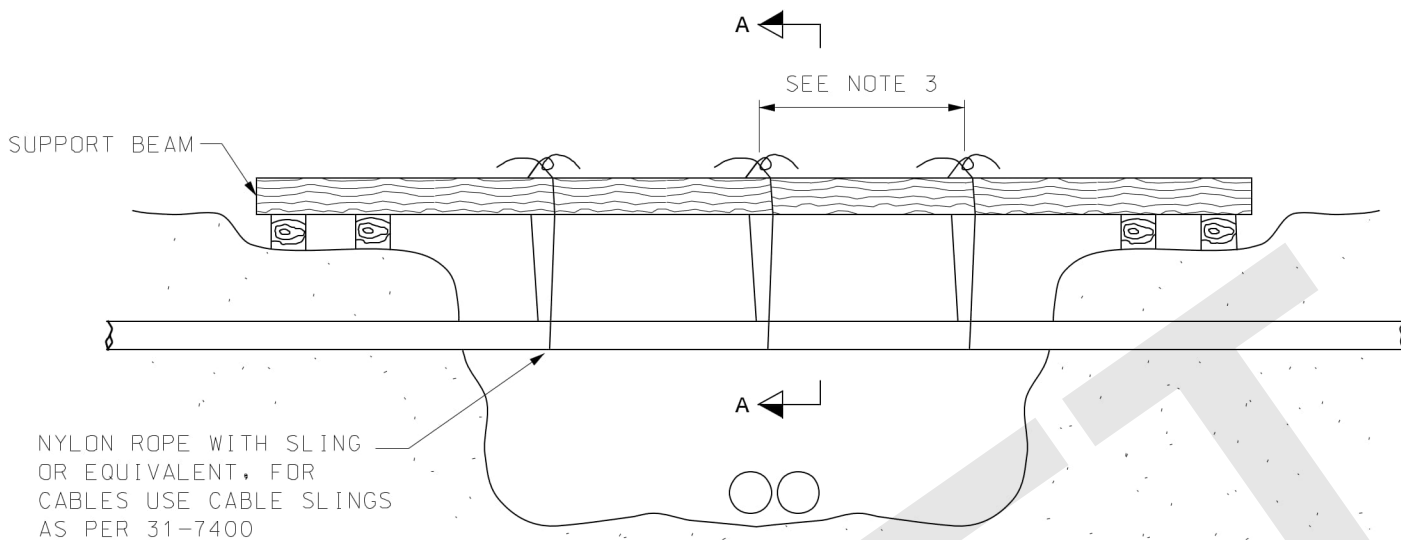

DIRECT BURIED DUCT OR CABLE

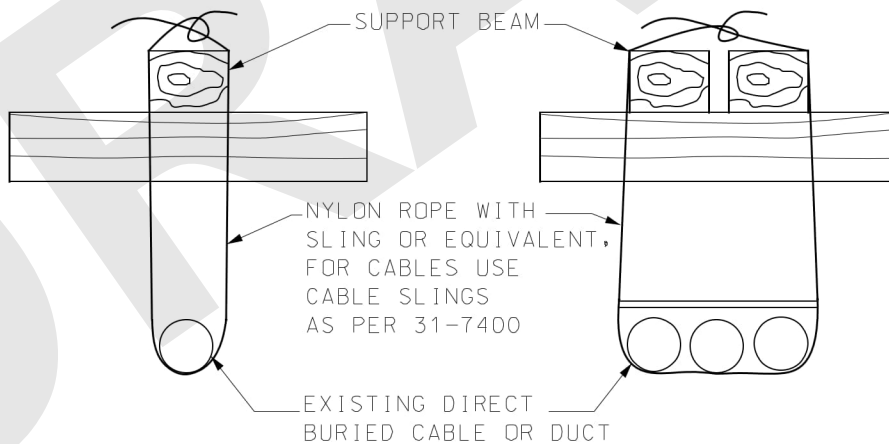

SECTION 'A-A'

MULTIPLE CABLES OR DUCTS

DISTRIBUTION CONSTRUCTION STANDARD
Civil Construction

**DUCT OR CABLE
SUPPORT IN PLACE SYSTEM**



Approved By:

Drafted By:
B.D.

Designed By:
J.D.

Original Issue:
G.D./C.P. 2002-11-25

Scale:
N.T.S.

Rev: **3**

31-1350

3/4

© CERTIFIED BY TORONTO HYDRO STANDARD <STANDARDS@TORONTOHYDRO.COM>; THIS DOCUMENT IS FOR USE BY TORONTO HYDRO AND AUTHORIZED PERSONS ONLY AS PER THE TERMS IN TORONTO HYDRO STANDARD 00-0002.

NOTES: 

- 1) THIS DRAWING IS TO BE USED ONLY AS A GUIDELINE AS THE SUPPORT STRUCTURE ELEMENTS WILL BE SITE SPECIFIC.
- 2) TEMPORARY SUPPORT IS REQUIRED WHENEVER THE UNDERGROUND CONDUIT IS UNDERMINED FOR MORE THAN 1200 mm (3'-11") IN LENGTH. ALL SUCH SUPPORTS SHALL MEET REQUIREMENTS OF NOTE #2.
- 3) THE CONTRACTOR/CONSULTANT SHALL PROVIDE A DETAILED DRAWING FOR THE SUPPORT SYSTEM SIGNED AND SEALED BY A PROFESSIONAL CIVIL ENGINEER OF ONTARIO TO SUIT SITE CONDITIONS. ENGINEER SHALL ACCOUNT FOR CABLE PULLING TENSION, LIVE LOADS, WIND LOADS, AND MAINTENANCE LOADS IN THEIR CALCULATIONS.
- 4) WHEN SUPPORTED FROM ABOVE, DIRECT BURIED DUCTS AND DIRECT BURIED CABLE, SPACING BETWEEN SUPPORTS SHALL NOT EXCEED 0.6 m (2'-0").
- 5) FOR CONCRETE ENCASED AND DIRECT BURIED DUCTS, VERTICAL OR HORIZONTAL DISPLACEMENT SHALL NOT EXCEED 19 mm (3/4") OR 10 mm (3/8"), RESPECTIVELY. STRUCTURAL DAMAGE OR DISPLACEMENT OUTSIDE OF THIS RANGE SHALL BE REPORTED TO TORONTO HYDRO.
- 6) FOR CONCRETE ENCASED AND DIRECT BURIED DUCTS, MONITORING OF SUPPORT STRUCTURE WITH RESPECT TO HORIZONTAL, VERTICAL, AND VIBRATIONAL MOVEMENTS SHALL BE PROVIDED.
- 7) TEMPORARY SUPPORT WILL REMAIN IN-PLACE UNTIL THE BACK FILL MATERIAL UNDER THE STRUCTURE HAS BEEN COMPACTED ADEQUATELY TO RESTORE SUPPORT. BACKFILL ON TOP TO BE AS PER CV-CDN-01.
- 8) ALTERNATIVE METHODS OF SUPPORT SYSTEM CAN BE CHOSEN BUT WILL REQUIRE TORONTO HYDRO TO REVIEW AND APPROVE.
- 9) TIMBER BOX TO BE PAINTED RED AND MARKED WITH SAFETY "DANGER" SIGN.
- 10) DAMAGED DIRECT BURIED DUCTS OR CONCRETE ENCASED DUCTS WILL REQUIRE TO BE REBUILT PRIOR TO SUPPORT IN PLACE INSTALLATION.
- 11) CONTRACTOR IS RESPONSIBLE TO MEET ALL REQUIREMENTS WITH CONSIDERATION TO SUPPORTING OR WORKING CLOSE TO LIVE ENERGIZED CABLES.

DRAFT

DISTRIBUTION CONSTRUCTION STANDARD
Civil Construction

**DUCT OR CABLE
SUPPORT IN PLACE SYSTEM**



Approved By:

Drafted By:
B. D.

Designed By:
J. D.

Original Issue:
G. D. / C. P. 2002-11-25

Scale:
N. T. S.

Rev: **3**

31-1350

4/4

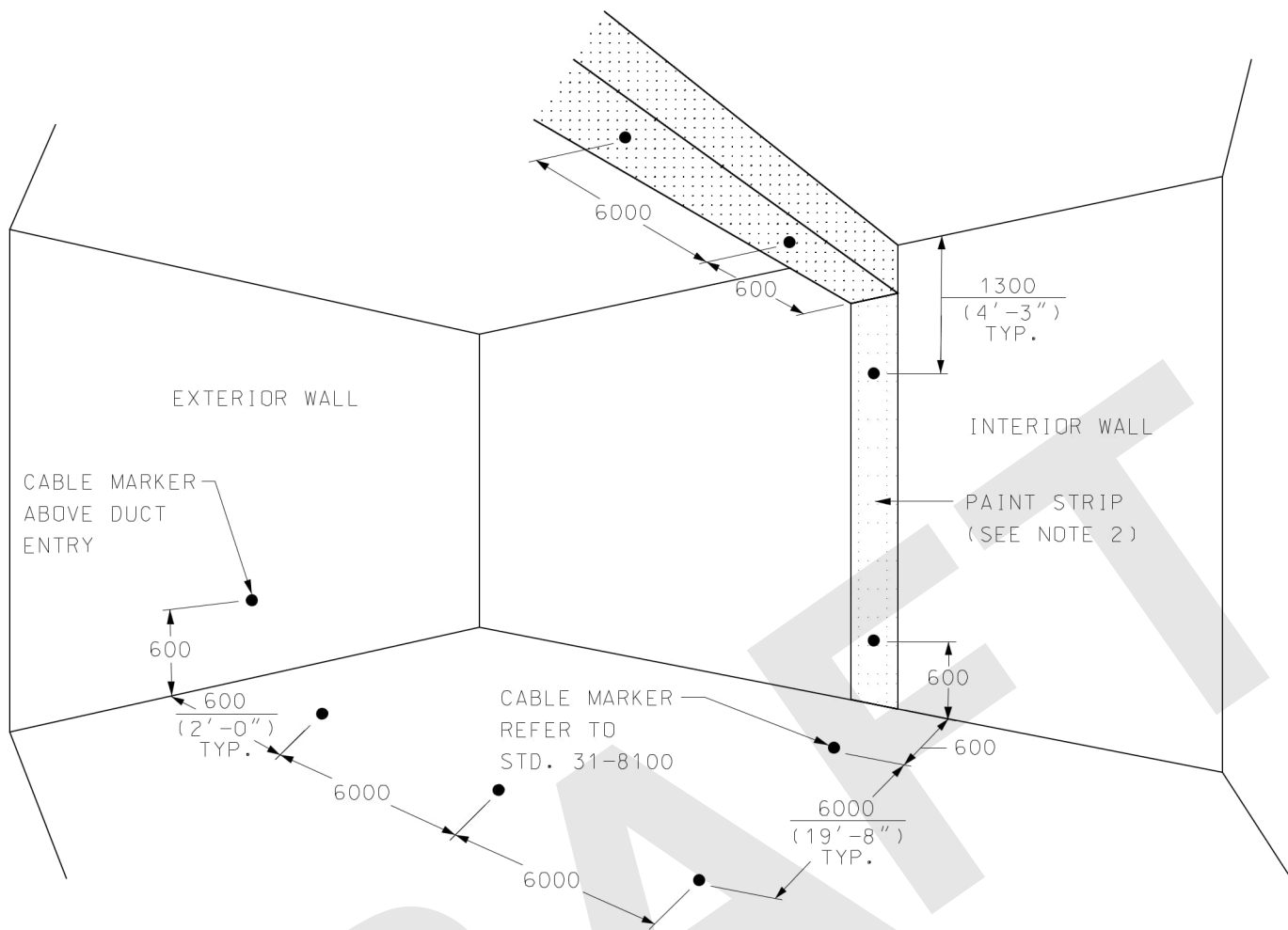

**DUCT IDENTIFICATION IN GARAGE FLOOR,
CEILING OR INTERIOR WALL**

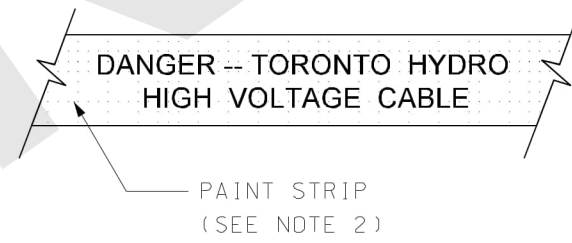

**DUCT IDENTIFICATION IN GROUND LEVEL FLOOR
UNDER CARPET OR FLOORING**

NOTES: ⚠

- 1) CABLE MARKER TO BE INSTALLED FLUSH WITH SURFACE OF DUCT STRUCTURE.
- 2) PAINT STRIP TO BE 600 mm (2'-0") WIDE OR MAXIMUM WIDTH OF DUCT STRUCTURE.
- 3) FLUORESCENT PAINT TO BE RED EXTERIOR ACRYLIC LATEX.
- 4) LETTERING TO BE BLACK EXTERIOR LATEX PAINT.
- 5) PERMANENT IDENTIFICATION MUST BE COMPLETED BEFORE THE SERVICE IS ENERGIZED.

DISTRIBUTION CONSTRUCTION STANDARD
Civil Construction

**CONDUITS
IDENTIFICATION OF HYDRO DUCTS IN BUILDING COMPLEXES**



Approved By:

J.D. 2012-11-09

Drafted By:

D.L.

Designed By:

J.D.

Original Issue:

G.D./C.P. 2004-03-31

Scale:

N.T.S.

Rev:

1

31-1360

1/1

© CERTIFIED BY TORONTO HYDRO STANDARD <STANDARDS@TORONTOHYDRO.COM>. THIS DOCUMENT IS FOR USE BY TORONTO HYDRO AND AUTHORIZED PERSONS ONLY AS PER THE TERMS IN TORONTO HYDRO STANDARD 00-0002.

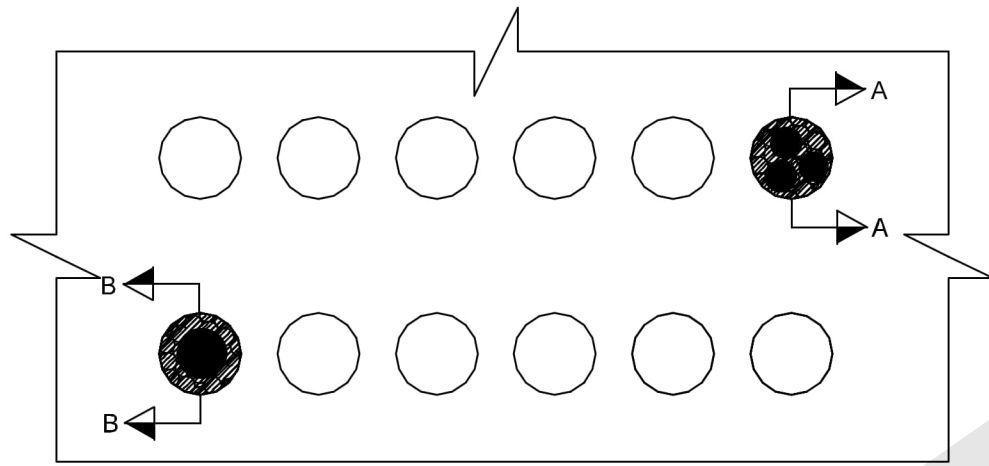

**DUCT BANK
FRONT VIEW**

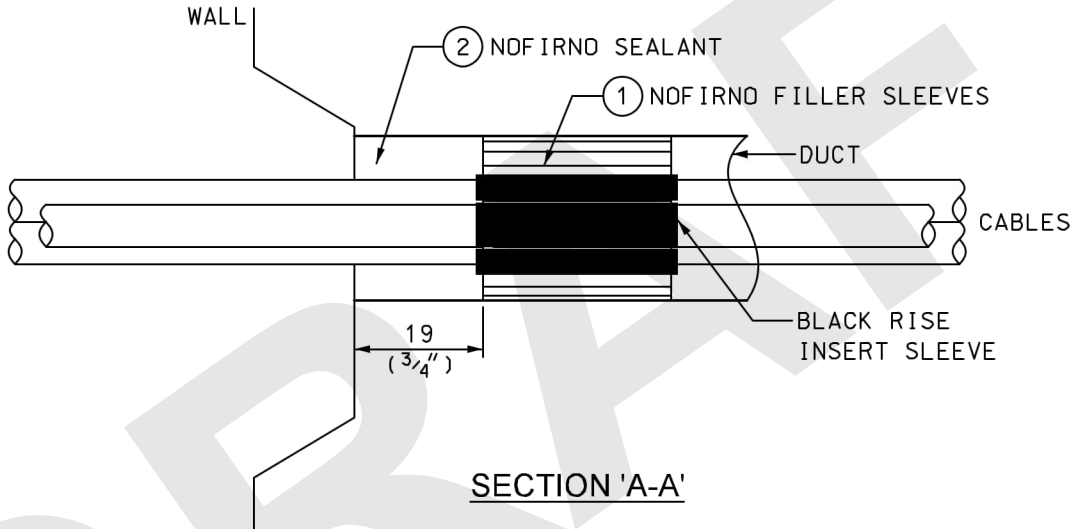

SECTION 'A-A'

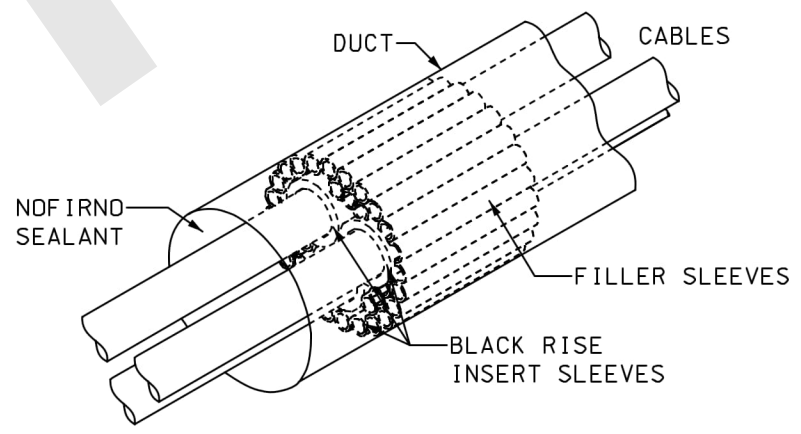

INSTALLATION IN DRY DUCT

DISTRIBUTION CONSTRUCTION STANDARD
Civil Construction

DUCT SEALANT INSTALLATION



Approved By: 2021/10/21
Drafted By: J.D.
Designed By: B.D.

Original Issue:
J.D. 2015-11-23

Scale:
N.T.S.

Rev: 2

31-1400

1/3

© CERTIFIED BY TORONTO HYDRO STANDARD <STANDARDS@TORONTOHYDRO.COM>. THIS DOCUMENT IS FOR USE BY TORONTO HYDRO AND AUTHORIZED PERSONS ONLY AS PER THE TERMS IN TORONTO HYDRO STANDARD 00-0002.

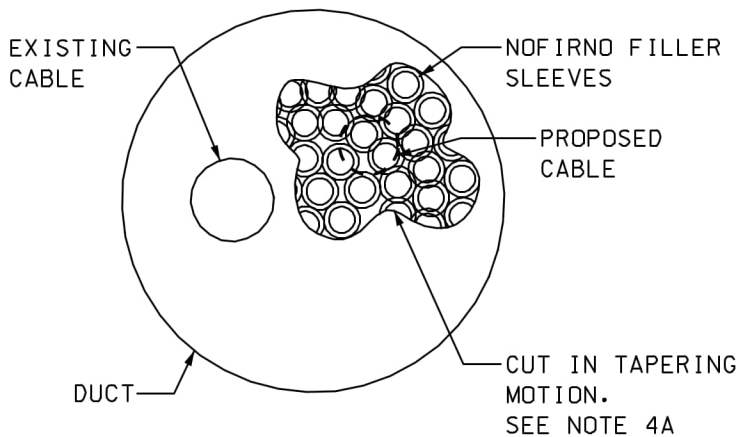
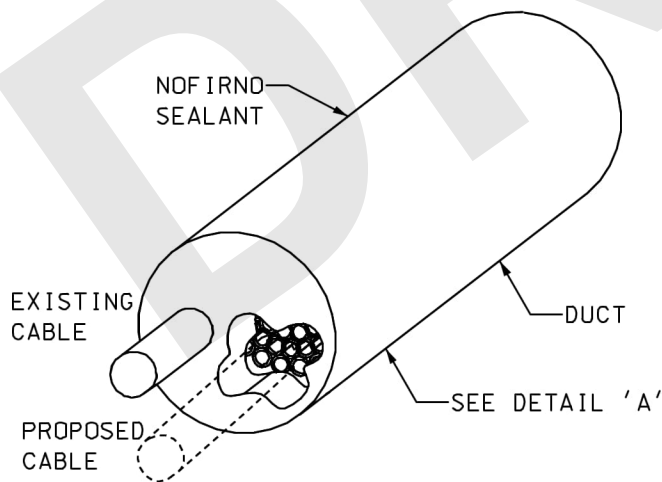
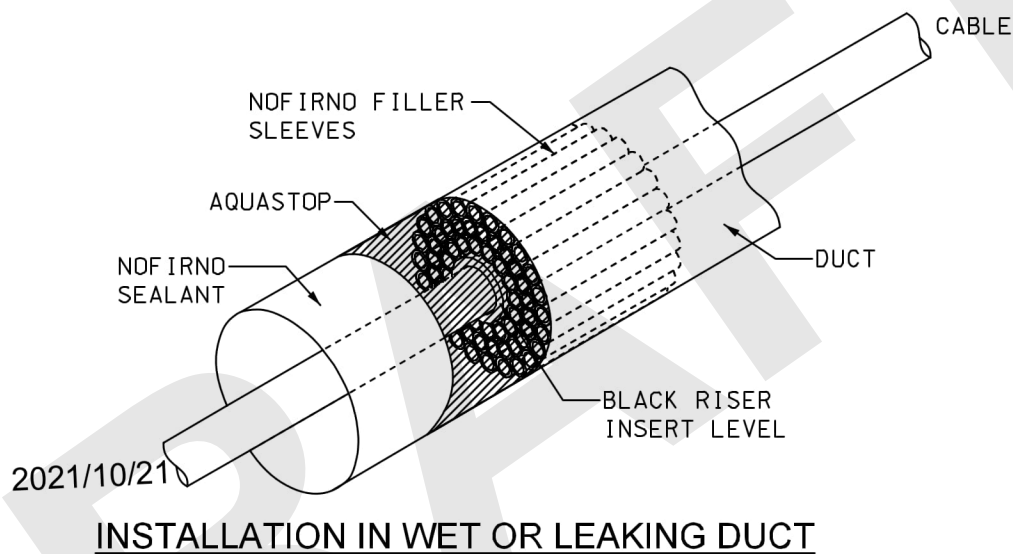
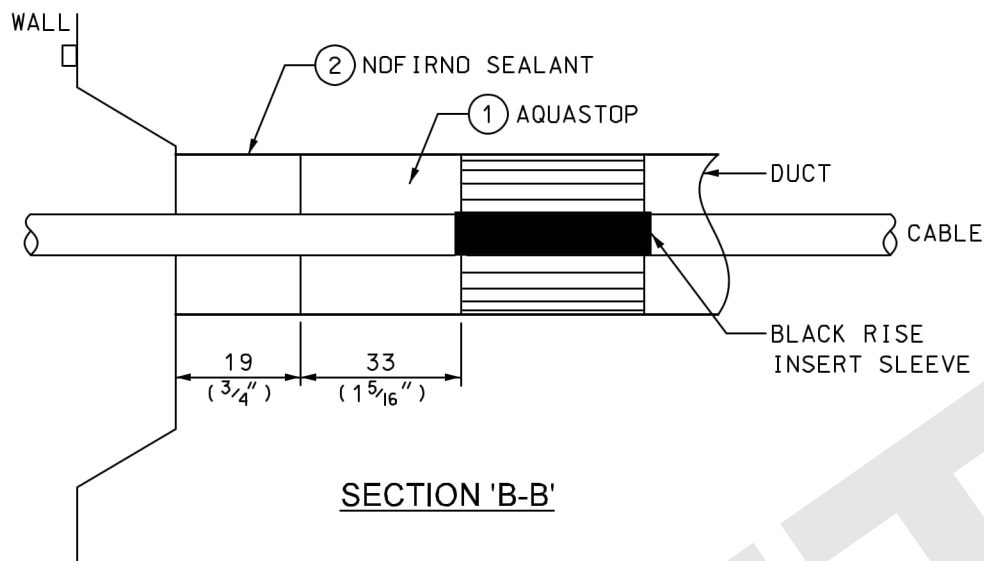

DISTRIBUTION CONSTRUCTION STANDARD
Civil Construction

DUCT SEALANT INSTALLATION



Approved By:
2021/10/21

Drafted By:
J.D.

Designed By:
B.D.

Original Issue:
J.D. 2015-11-23

Scale:
N.T.S.

Rev:

2

31-1400

2/3

BILL OF MATERIALS FOR 31-1400			
ITEM NO.	DESCRIPTION	ITEM I.D.	QTY
* 1	DUCT SEALANT KIT	9665194	1
+ 2	SEALANT	9665195	1
+ 3	CAULKING GUN	2730104	1

- + AS REQUIRED
- * DUCT SEALANT KIT INCLUDES:
 - NOFIRNO FILLER SLEEVES
 - BLACK RISE INSERT SLEEVES
 - AQUASTOP

NOTES:

1) SEALANT SHALL BE APPLIED TO:

-  - DUCTS EXITING THESE STRUCTURES (POLES, CABLE CHAMBERS, PADMOUNTS, SPLICE VAULTS, TAP/SPLICE BOXES AND VAULTS) WHEN FEEDING INTO CUSTOMER'S BUILDING/VAULTS AND ALSO DUCTS AT CUSTOMER'S BUILDING/VAULTS ENTRANCE POINT;
- LOCATIONS WHERE EXISTING SEALANT (STOCK CODES 8940011, 9656790 OR 9656791) IS NOT ADEQUATE.

2) INSTALLATION IN DRY DUCT (AS PER SECTION 'A-A'):

- A) CLEAN THE DUCT AND CABLE THOROUGHLY USING A CLOTH TO REMOVE ALL DEBRIS AND DIRT FROM INSIDE THE DUCT. DO NOT USE HAND SANITIZER CLOTHS OR CLOTHS MIXED WITH SOAPY MIXTURE.
- B) PLACE BLACK RISE INSERT SLEEVES AROUND EACH CABLE.
- C) FILL THE REMAINDER OF THE SPACE IN DUCT WITH RED NOFIRNO FILLER SLEEVES 22/15 (22 mm (9/10") OUTER DIAMETER AND 15 mm (3/8") INNER DIAMETER).
- D) ADJUST THE SLEEVES SO THAT THEY ARE ALIGNED AND RECESSED, BY USING NEEDLE NOSE PLIERS.
- E) OVERFILL THE DUCT WITH NOFIRNO SEALANT.
- F) USING A WET CLOTH, COMPRESS AND SMOOTHEN THE NOFIRNO SEALANT FOR A SMOOTH SURFACE.

3) INSTALLATION IN WET OR LEAKING DUCTS (AS PER SECTION 'B-B'):

- A) FOLLOW PROCEDURES AS PER 2A, 2B AND 2C.
- B) INSERT THE AQUASTOP INTO THE DUCT AGAINST THE NOFIRNO FILLER SLEEVES.
- C) TIGHTLY COMPRESS THE AQUASTOP AGAINST THE FILLER SLEEVES BY HAND OR BY USING A WOOD PIECE OR ANY OBJECT WITH A FLAT SURFACE.
- D) ENSURE THE EDGES ARE PROPERLY SEALED BY SMEARING THE AQUASTOP RUBBER ALONG THE EDGES OF THE DUCT WALL. ENSURE THAT THERE IS AT LEAST 19 mm (3/4") OF SPACING BETWEEN THE FINAL LAYER OF AQUASTOP STRIP AND DUCT EDGE.
- E) INSPECT THE DUCT TO ENSURE THAT THE LEAKAGE HAS STOPPED. IN ORDER TO EXPEDITE DRYING TIME, USE A DRYER. DO NOT USE A HEAT GUN, AS PROLONGED USE WILL DAMAGE CABLE.
- F) APPLY THE NOFIRNO SEALANT OVER THE AQUASTOP UNTIL THE DUCT OVERFLOWS.
- G) USING A WET CLOTH, COMPRESS AND SMOOTHEN THE NOFIRNO SEALANT.

4) ADDING ADDITIONAL CABLES TO DRY DUCT CONTAINING NOFIRNO SEALANT (AS PER DETAIL 'A'):

- A) USING A KNIFE, PENETRATE THE NOFIRNO SEALANT LAYER (AND AQUASTOP LAYER, IF APPLICABLE) AND BEGIN TO CUT SEALANT WIDE ENOUGH TO ACCOMMODATE THE OUTER DIAMETER OF THE CABLE TO BE PULLED INTO THE DUCT. A TAPERING MOTION SHALL BE USED TO ENSURE APPROPRIATE MASS IS AVAILABLE FOR RE-SEAL.
- B) REMOVE THE APPROPRIATE AMOUNT OF NOFIRNO FILLER SLEEVES, IN ORDER TO ACCOMMODATE THE OUTER DIAMETER OF THE CABLE TO BE PULLED INTO THE DUCT.
- C) PULL THE DESIRED CABLE THROUGH THE DUCT AND ADD A BLACK RISE INSERT SLEEVE AROUND THE CABLE.
- D) PUSH THE RISE INSERT SLEEVES INTO THE DUCT AT A DEPTH OF 19 mm (3/4") FROM THE DUCT OPENING.
- E) FOLLOW PROCEDURES AS PER 2D AND 2E.

DISTRIBUTION CONSTRUCTION STANDARD
Civil Construction



Approved By:
2021/10/21

DUCT SEALANT INSTALLATION

Drafted By: U. K.	Designed By: B. D.	Original Issue: J. D. 2015-11-23	Scale: N. T. S.	Rev: 2	31-1400	3/3
----------------------	-----------------------	-------------------------------------	--------------------	-----------	---------	-----

© CERTIFIED BY TORONTO HYDRO STANDARD <STANDARDS@TORONTOHYDRO.COM>, THIS DOCUMENT IS FOR USE BY TORONTO HYDRO AND AUTHORIZED PERSONS ONLY AS PER THE TERMS IN TORONTO HYDRO STANDARD 00-0002.

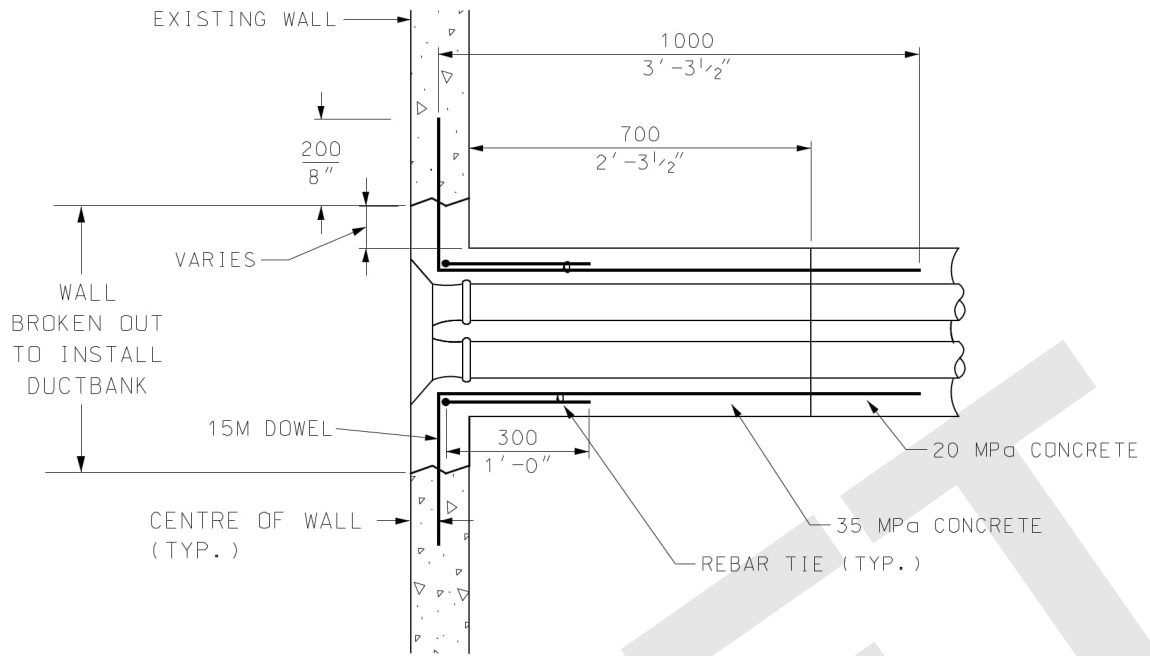

CONNECTION INTO EXISTING WALL

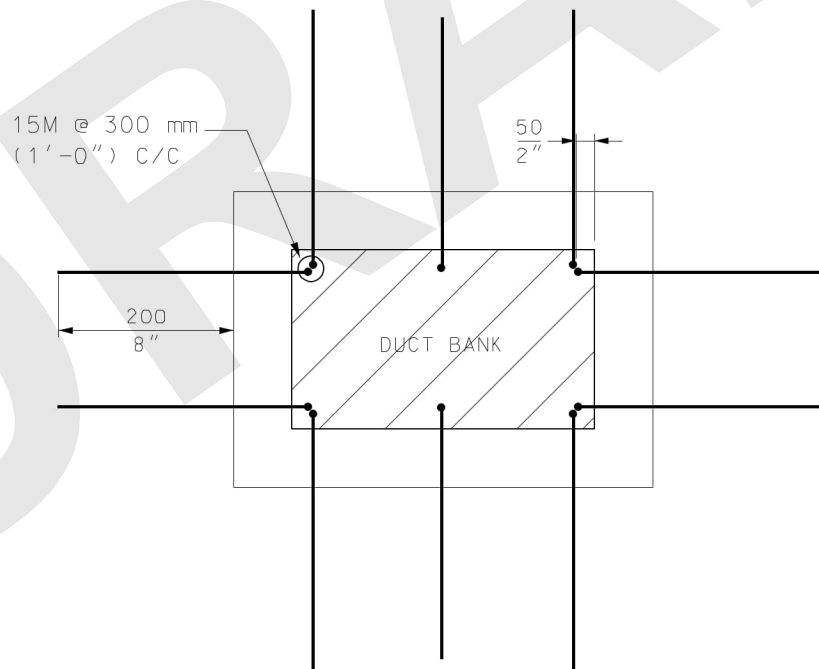

ELEVATION VIEW

DISTRIBUTION CONSTRUCTION STANDARD
Civil Construction



Approved By:
B.D., 2019-03-22

Drafted By:
B.D.

Designed By:
B.D.

Original Issue:
B.D., 2019-03-22

Scale:
N.T.S.

Rev: 0

31-1600

1/2

**CONDUITS
NEW DUCT BANK RECESS
INSTALLATION IN EXISTING STRUCTURES**

NOTES:

- 1) DRILL 15M DOWEL BARS INTO EXISTING CONCRETE WALL FOR A LENGTH OF AT LEAST 200 mm (8"). USE HILTI HY-200 CHEMICAL ADHESIVE ANCHORS ACCORDING TO THE MANUFACTURERS INSTRUCTIONS.
- 2) ALL REINFORCEMENT BARS SHALL CONFORM TO LATEST CSA STANDARD G30.18, Fy=400 MPa.
- 3) WITHIN 700 MM OF EXTERIOR WALL FACE, CONCRETE SHALL HAVE A MINIMUM 28-DAY COMPRESSIVE STRENGTH OF 35 MPa AND EXPOSURE CLASS OF C-1 AS DEFINED IN CSA A23.1.
- 4) FOR CABLE CHAMBERS, IF CABLE PULLING LOOPS ARE REQUIRED, INSTALL IN ACCORDANCE TO TORONTO HYDRO STANDARD 31-8220. CABLE PULLING LOOP SHALL BE IN-LINE WITH AND ON OPPOSITE WALLS OF EACH DUCT FACE (TYPICAL 300 mm (1'-0") FROM FINISHED FLOOR).
- 5) DUCT BANK RECESS INSTALLATION SHALL APPLY TO DUCT CONFIGURATIONS GREATER THAN 6 DUCTS. NUMBER OF DUCTS WITHIN RECESS SHALL NOT EXCEED 24. DUCT CONFIGURATIONS SHALL BE IN ACCORDANCE WITH STD. 31-1120.
- 6) FOR DUCT BANK RECESS INSTALLED IN EXISTING STRUCTURES, CLEARANCES SHALL BE AS FOLLOWS:
 - MIN. 400 mm (1'-4") FROM CEILING;
 - MIN. 400 mm (1'-4") FROM ADJACENT WALLS;
 - MIN. 400 mm (1'-4") FROM OTHER DUCT BANKS.
 - MIN. 400 mm (1'-4") FROM FLOOR OR, IF APPLICABLE, MIN. 100 mm (4") ABOVE BACKWATER VALVE.
- 7) TO PREVENT DAMAGE TO REINFORCEMENT BARS ADJACENT TO RECESS, SAW OVERRUN SHALL BE AVOIDED DURING RECESS INSTALLATION.
- 8) INSTALLATION SHALL CONFORM TO THE LATEST EDITION OF TORONTO HYDRO TECHNICAL SPECIFICATION FOR CIVIL CONSTRUCTION WORK CV-CON-01.
- 9) THE CONTRACTOR SHALL ENSURE THAT THE WALL IS STRUCTURALLY SOUND PRIOR TO COMMENCING WORK. MINIMUM WALL THICKNESS SHALL BE 200 mm (8"). OTHERWISE CORE DRILLING SHALL BE USED FOR STRUCTURES HAVING WALL THICKNESS LESS THAN 200 mm (8"). NO RECESS SHALL BE INSTALLED IN A SUBMERSIBLE TRANSFORMER VAULT.
- 10) DUCT BANK RECESS SHALL BE PERFORMED BY AN APPROVED TORONTO HYDRO CONTRACTOR TO ENSURE THAT CONSTRUCTION COMPLIES WITH TORONTO HYDRO CIVIL SPECIFICATIONS, STANDARDS AND ALL RELEVANT ACCEPTABLE PRACTICES AND METHODS APPROVED BY TORONTO HYDRO.
- 11) THE CONTRACTOR SHALL PROVIDE TEMPORARY PROTECTION TO ALL CABLES LOCATED INSIDE THE STRUCTURE, AND WILL CLEAN, REMOVE AND DISPOSE OF ALL DEBRIS RESULTING FROM THE CONSTRUCTION.
- 12) THIS INSTALLATION SHALL NOT APPLY TO STRUCTURES CONSTRUCTED WITH CONCRETE BLOCKS/BRICKS.

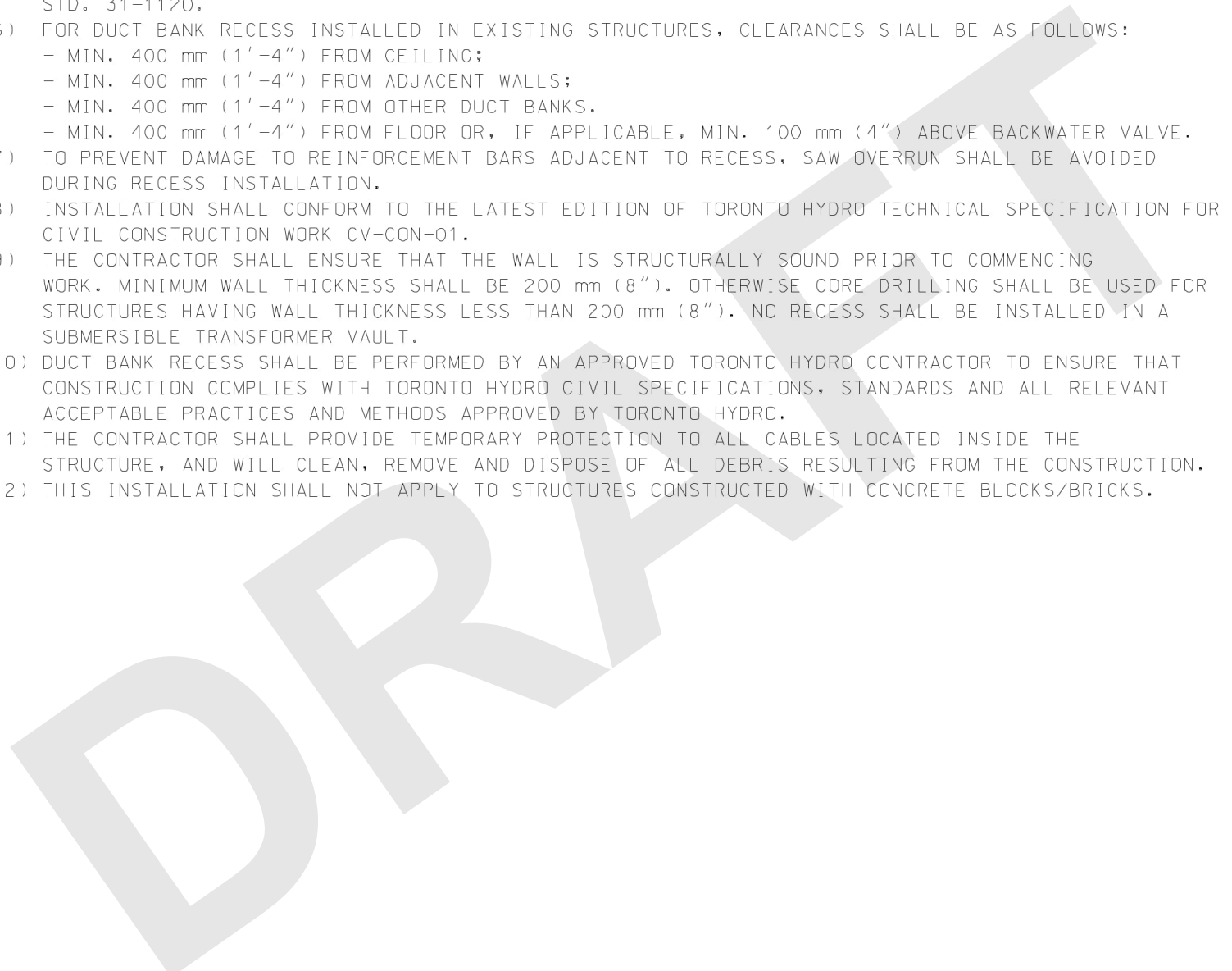

DISTRIBUTION CONSTRUCTION STANDARD
Civil Construction



Approved By:
B.D. 2019-03-22

Drafted By:
B.D.

Designed By:
B.D.

Original Issue:
B.D. 2019-03-22

Scale:
N.T.S.

Rev: 0

31-1600

2/2

**CONDUITS
NEW DUCT BANK RECESS
INSTALLATION IN EXISTING STRUCTURES**

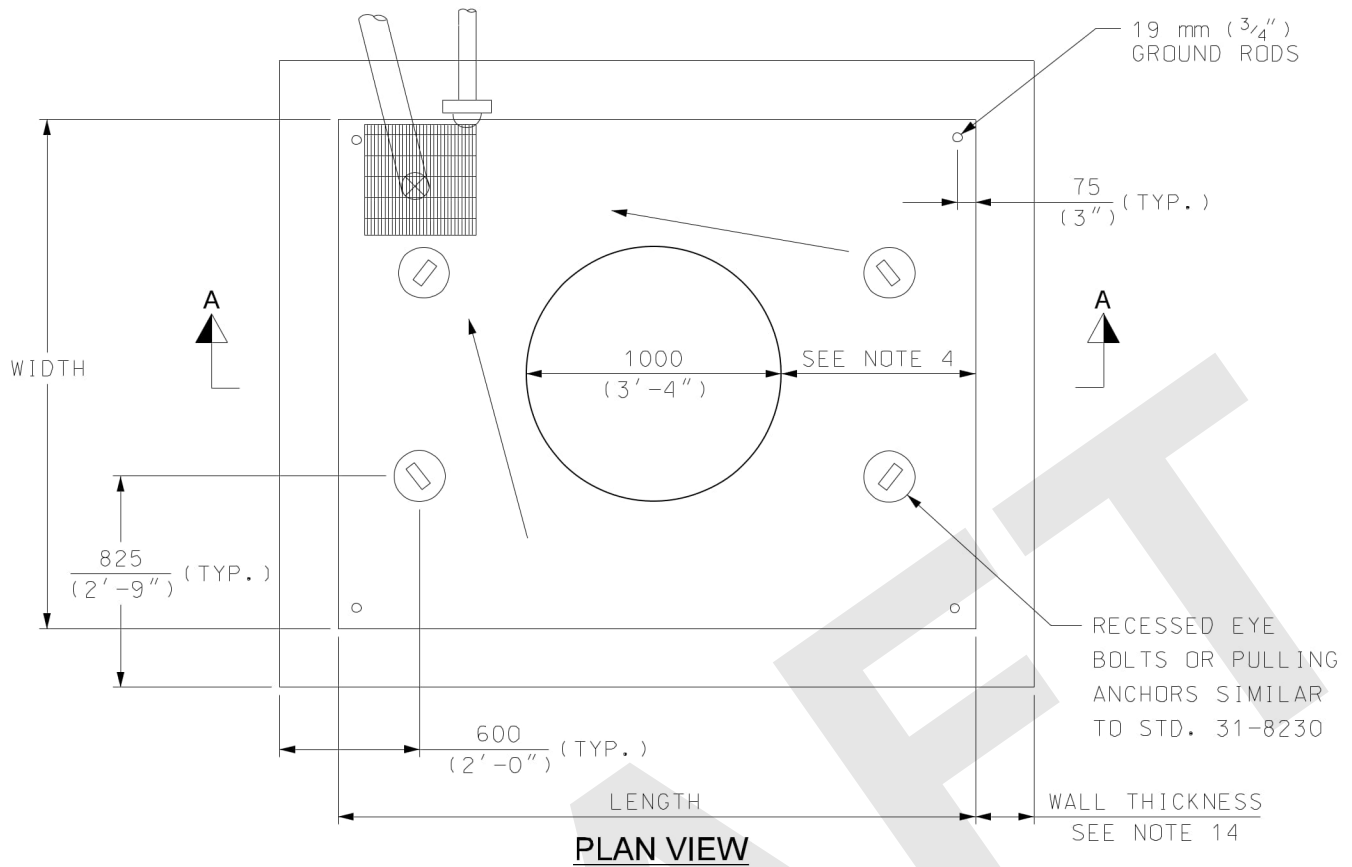

PLAN VIEW

NOTES:

- 1) ROOF SLAB AND WALLS SHALL BE DESIGNED IN ACCORDANCE WITH CANADIAN HIGHWAY BRIDGE DESIGN CODE CAN/CSA-S6-06, CL-625-QNT LIVE LOADING.
- 2) ALL CONCRETE SHALL HAVE A MIN. 28-DAY COMPRESSIVE STRENGTH OF 35 MPa. CONCRETE MIX AND PLACEMENT SHALL CONFORM TO LATEST CSA-A23.1. ALL TESTING SHALL CONFORM TO LATEST CSA-A23.2.
- 3) ALL REINFORCEMENT BARS SHALL CONFORM TO LATEST CSA STANDARD G30.18, Fy=400 MPa.
- 4) MIN. DISTANCE FROM CABLE CHAMBER ACCESS CHIMNEY (NECK) OPENING SHALL BE 450 (1'-6"). FOR 1000 kcmil XLPE CABLES, REFER TO STD. 31-2170 FOR MIN. DISTANCE FROM THE NECK.
- 5) THE EXTERIOR SURFACE OF THE ROOF AND NECK SHALL BE WATERPROOFED WITH A BITUMEN MEMBRANE.
- 6) PARGING MIX ON ALL BRICK WORK SHALL BE ONE PART NON-SHRINK CEMENT AND THREE PARTS SAND AND APPLIED 15 mm THICK.
- 7) CABLE PULLING LOOP SHALL BE IN-LINE WITH AND ON OPPOSITE WALL OF EACH DUCT FACE (TYPICAL 300 mm (1'-0") FROM FINISH FLOOR).
- 8) SUMP HOLE REMOVABLE TYPE GRATING, SHALL BE GALVANIZED AS PER LATEST CSA-G-164.
- 9) EXACT LOCATION OF FLOOR DRAIN OR SUMP HOLE SHALL BE DETERMINED AS PER CONSTRUCTION DRAWING.
- 10) LOCATION AND CONFIGURATION OF DUCT BANK SHALL BE AS DETAILED ON PROJECT CONSTRUCTION DRAWING.
- 11) CHAMBER SIZES SHALL BE AS SHOWN IN TABLE.
- 12) STRUCTURAL DESIGN OF PRECAST CHAMBER IS THE RESPONSIBILITY OF THE CONTRACTOR. DRAWINGS SHALL BE STAMPED AND SIGNED BY CONTRACTOR'S PROFESSIONAL ENGINEER.
- 13) CONTRACTOR OR MANUFACTURER SHALL SUBMIT SHOP DRAWINGS FOR REVIEW AND APPROVAL BY TORONTO HYDRO PRIOR TO FABRICATION.
- 14) MIN. WALL THICKNESS SHALL BE 200 mm (8").
- 15) IF CHAMBER WALLS ARE BUILT IN SECTIONS, SEAL BETWEEN SECTIONS SHALL BE INSTALLED TO PREVENT WATER FROM ENTERING THE CABLE CHAMBER.
- 16) ALL DUCT HOLES SHALL BE PLUGGED WITH DUCT PLUGS.
- 17) 4 GROUND RODS PROVISION SHALL BE PLACED IN FOUR CORNERS OF THE CABLE CHAMBER.
- 18) DELIVERY IS MADE BY CRANE-EQUIPPED TRUCKS, EXCAVATION SHALL BE READY, SAFE AND ACCESSIBLE FOR UNLOADING FROM THE REAR OF THE TRUCK. MIN. OVERHEAD CLEARANCE OF 5500 mm (18'-0") IS REQUIRED.

DISTRIBUTION CONSTRUCTION STANDARD
Civil Construction

**CABLE CHAMBERS
PRECAST CHAMBER**



Approved By:
J. D. 2014-10-08

Drafted By:
Y. A.

Designed By:
J. D.

Original Issue:
G. D. / L. G. 2000-12-30

Scale:
N. T. S.

Rev:
9

31-2160

1/2

© CERTIFIED BY TORONTO HYDRO STANDARD <STANDARDS@TORONTOHYDRO.COM>; THIS DOCUMENT IS FOR USE BY TORONTO HYDRO AND AUTHORIZED PERSONS ONLY AS PER THE TERMS IN TORONTO HYDRO STANDARD 00-0002.

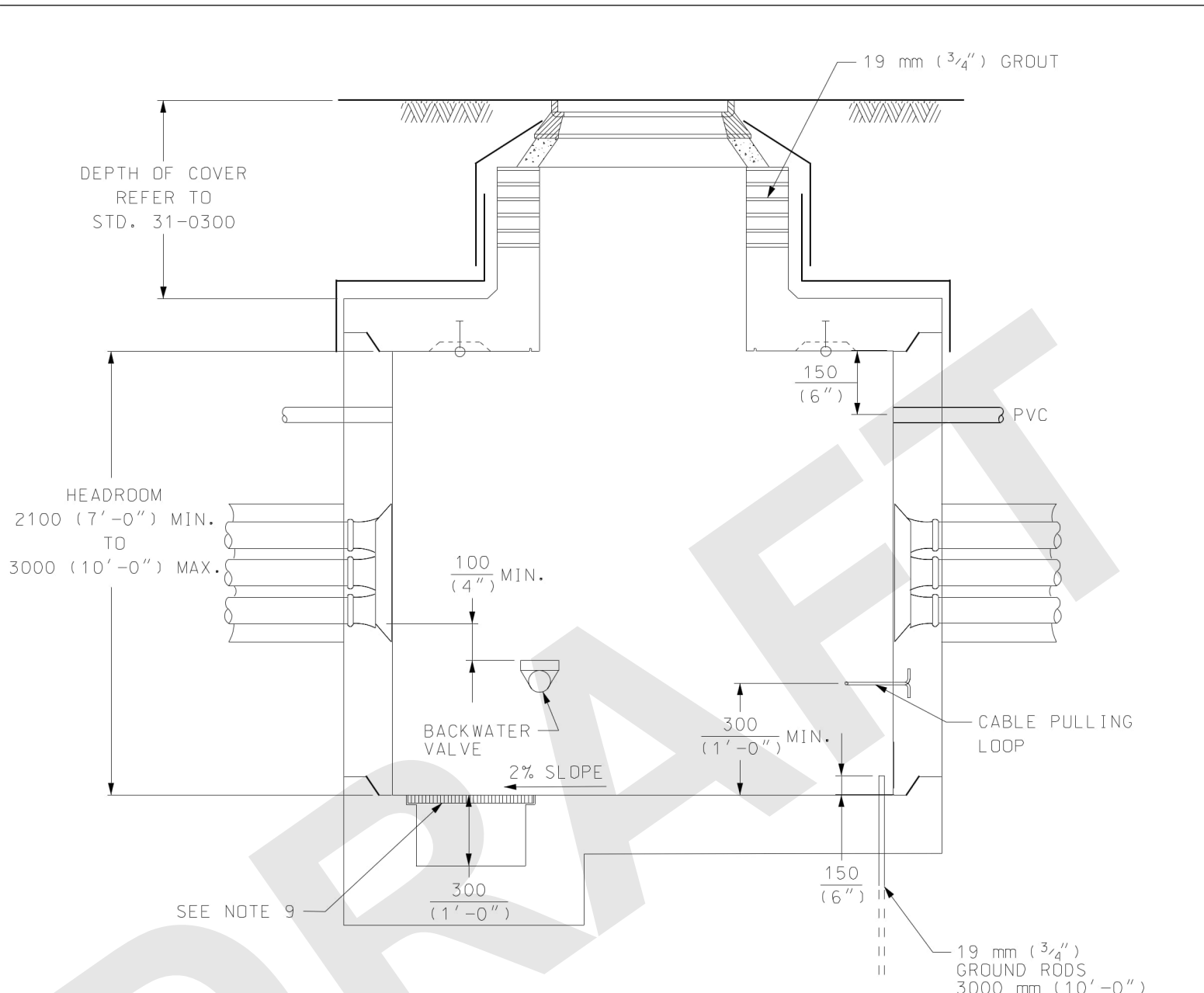

SECTION "A-A"

CHAMBER SIZES		
TYPE #	WIDTH	LENGTH
1	2000 (6'-8")	2500 (8'-4")
2	2000 (6'-8")	3000 (10'-0")
3	2500 (8'-4")	3000 (10'-0")
4	2500 (8'-4")	3500 (11'-6")
5	2500 (8'-4")	4000 (13'-4")
6	3000 (10'-0")	3000 (10'-0")
7	3000 (10'-0")	3500 (11'-8")
8	3000 (10'-0")	4000 (13'-4")
9	3500 (11'-8")	4000 (13'-4")

DISTRIBUTION CONSTRUCTION STANDARD Civil Construction		CABLE CHAMBERS PRECAST CHAMBER				
	Approved By:					
	J. D. 2014-10-08					
Drafted By:	Designed By:	Original Issue:	Scale:	Rev:		
Y. A.	J. D.	G. D. / L. G. 2000-12-30	N. T. S.	9	31-2160	
					2/2	

© CERTIFIED BY TORONTO HYDRO STANDARD <STANDARDS@TORONTOHYDRO.COM>, THIS DOCUMENT IS FOR USE BY TORONTO HYDRO AND AUTHORIZED PERSONS ONLY AS PER THE TERMS IN TORONTO HYDRO STANDARD 00-0002.

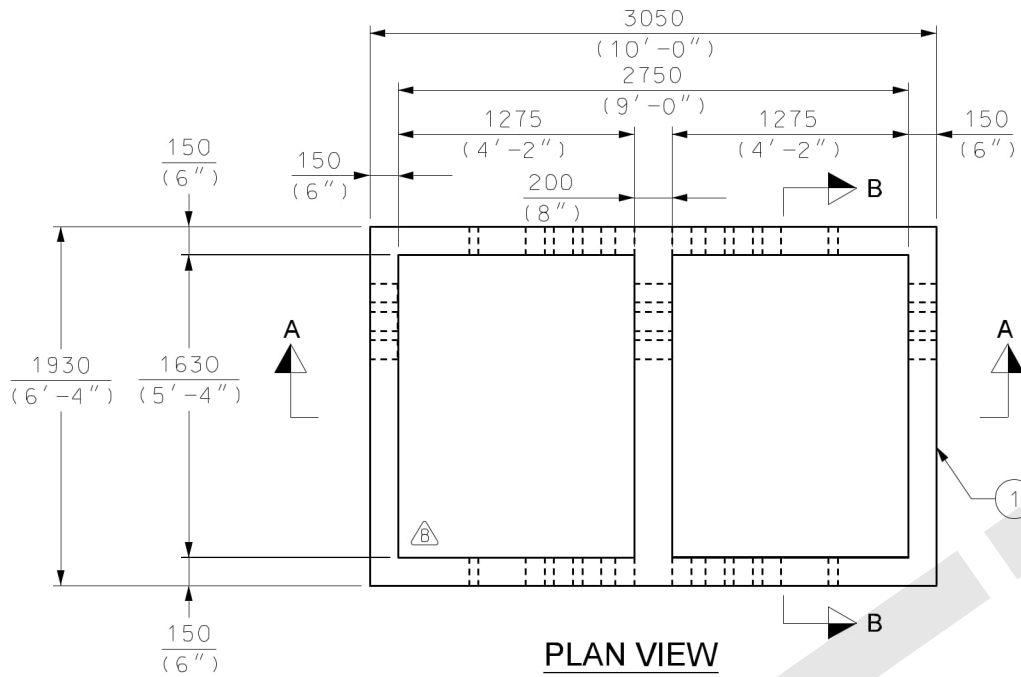

PLAN VIEW

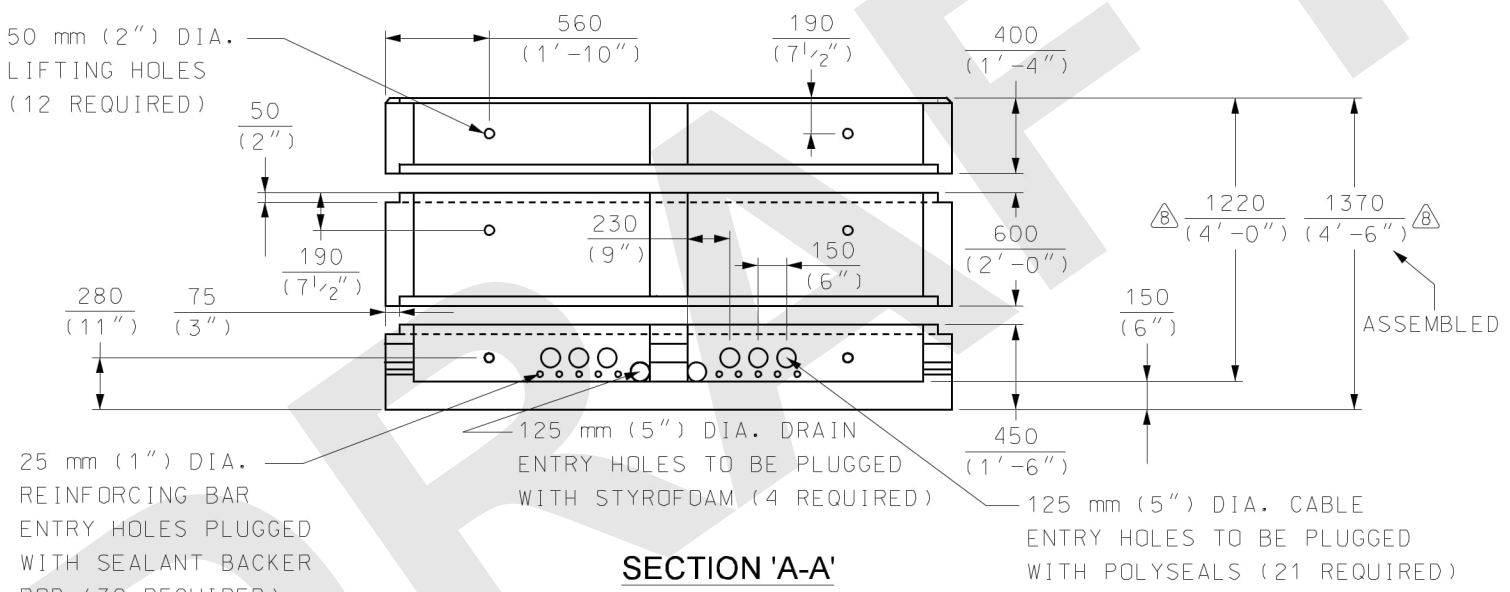

SECTION 'A-A'

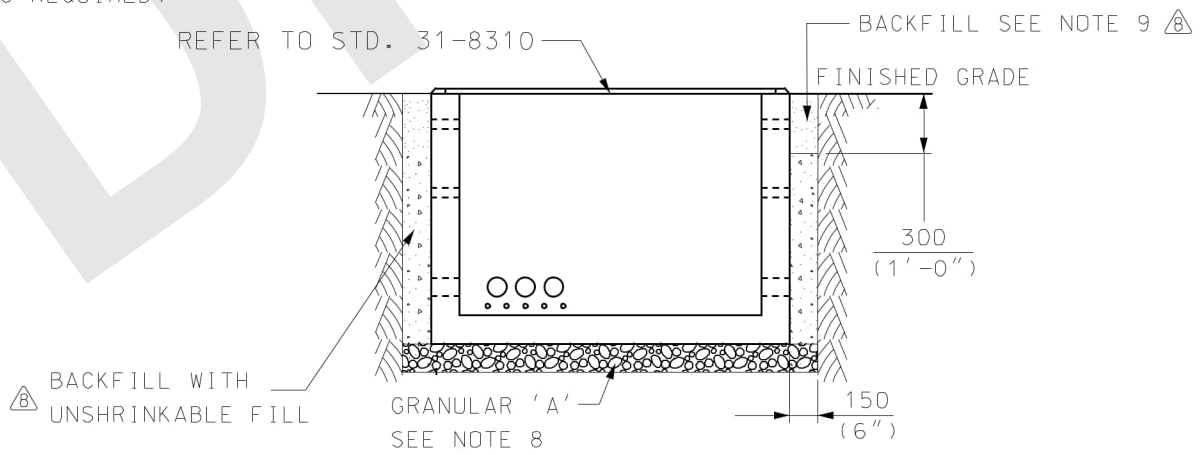

SECTION 'B-B'

DISTRIBUTION CONSTRUCTION STANDARD Civil Construction		VAULTS				
		SPLICE VAULT 'B' - 3 PIECE PRECAST				
		1930 mm (6'-4") x 3050 mm (10'-0") x 1370 (4'-6") mm DEEP				
	Approved By: B.D. 2018-08-28			Scale: N.T.S.	Rev: 8	31-2240
	Drafted By: M.D.	Designed By: B.D.	Original Issue: G.D./C.P. 2003-05-30			

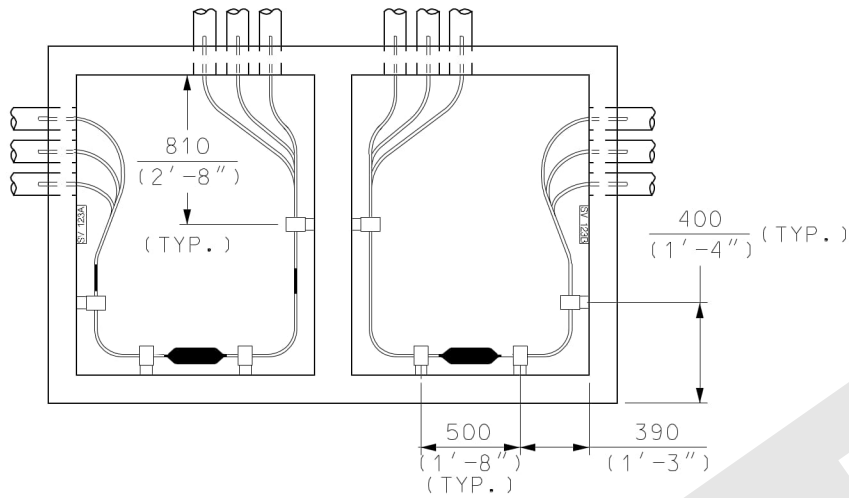

TYPICAL SPLICE RACKING

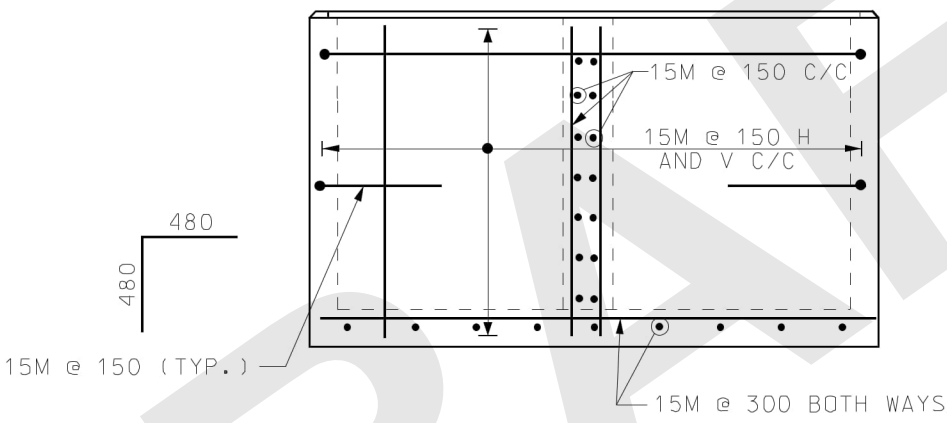

**DETAIL 'A'
WALL AND FLOOR REINFORCEMENT**

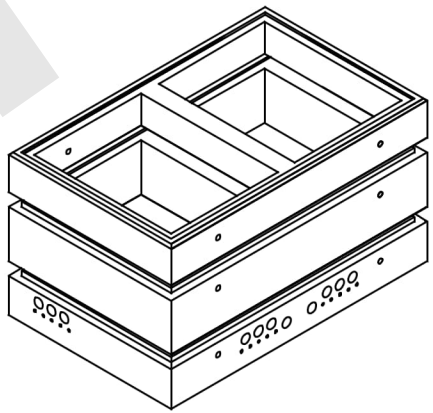

ISOMETRIC

DISTRIBUTION CONSTRUCTION STANDARD
Civil Construction



Approved By:
B.D. 2018-08-28
Drafted By:
M.D.
Designed By:
B.D.

Original Issue:
G.D./C.P. 2003-05-30

VAULTS

SPLICE VAULT 'B' - 3 PIECE PRECAST
1930 mm (6'-4") x 3050 mm (10'-0") x 1370 (4'-6") mm DEEP

Scale:
N.T.S.

Rev:
8

31-2240

2/4

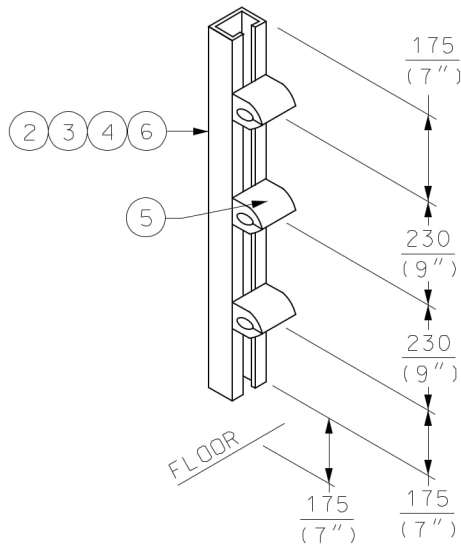

CABLE SUPPORT

NOTES:

MATERIAL:

- 1) CONCRETE SHALL HAVE A MIN. 28-DAY COMPRESSIVE STRENGTH OF 35 MPa. CONCRETE PRODUCTION AND PLACEMENT SHALL CONFORM TO LATEST CSA-A23.1. ALL TESTING SHALL CONFORM TO LATEST CSA-A23.2.
- 2) MANUFACTURER SHALL ADD DATE OF MANUFACTURE STAMP ON ALL PRECAST UNITS.
- 3) EXPOSURE CLASSIFICATION TO FREEZING AND THAWING IN A SATURATED CONDITION BUT WITH NO CHLORIDES SHALL BE F-1. ALL REINFORCING TO CONFORM TO LATEST CSA STANDARD G30.18, $F_y = 400 \text{ MPa}$.
- 4) CONCRETE COVER ON PRECAST UNIT SHALL BE 50 mm (2").
- 5) ALL EXPOSED EDGES SHALL HAVE 25 mm (1") CHAMFER.
- 6) LIFTING HOLES CAN BE INSTALLED IN FOUNDATION WALLS FOR MANUFACTURER'S LIFTING PREFERENCE.
- 7) 4-LIFTING ANCHORS FOR LIFTING PURPOSES BY OTHERS SHALL BE PROVIDED ON THE INSIDE OF ALL FOUNDATION WALLS. LIFTING ANCHORS SHALL BE GALVANIZED. LIFTING ANCHORS SHALL BE CAPABLE OF LIFTING THE PRECAST UNITS AND THIS SHALL BE CERTIFIED BY MANUFACTURER PRIOR TO DELIVERY.

INSTALLATION:

- 8) PLACE 150 mm (6") GRANULAR "A" BEDDING ON UNDISTURBED SOIL CAPABLE OF SUSTAINING 75 KPa AND COMPACT TO 95% STANDARD PROCTOR DENSITY.
- Ⓜ 9) EXCAVATION SHALL BE BACKFILLED TO FINISHED GRADE AS PER TORONTO HYDRO CIVIL SPECIFICATION CV-CON-01 AND/OR CITY OF TORONTO'S LATEST BACKFILLING REQUIREMENT.
- Ⓜ 10) TORONTO HYDRO INSPECTOR SHALL BE PRESENT DURING THE INSTALLATION, 24-HOUR NOTICE IS REQUIRED PRIOR TO STARTING THE INSTALLATION.
- Ⓜ 11) DRAIN CONNECTION SHALL BE AS PER STANDARD 31-7100.
- Ⓜ 12) UNUSED CABLE ENTRY DUCTS SHALL BE PLUGGED WITH DUCT PLUGS AND PARGED PRIOR TO BACKFILLING.
- Ⓜ 13) CONTRACTOR TO PLUG ALL HOLES (LIFTING AND GROUNDING) AND PARGED PRIOR TO BACKFILLING.
- Ⓜ 14) PRECAST UNITS ARE DELIVERED BY CRANE-EQUIPPED TRUCKS. EXCAVATION MUST BE READY, SAFE AND ACCESSIBLE FOR UNLOADING FROM THE REAR OF THE TRUCK. MIN. OVERHEAD CLEARANCE OF 5500 mm (18'-0") IS REQUIRED. CONTRACTOR SHALL ASSIST SUPPLIER IN LOWERING THE PRECAST UNITS INTO EXCAVATION.

DISTRIBUTION CONSTRUCTION STANDARD
Civil Construction

VAULTS
SPLICE VAULT 'B' - 3 PIECE PRECAST
1930 mm (6'-4") x 3050 mm (10'-0") x 1370 (4'-6") mm DEEP



Approved By:
B.D. 2018-08-28

Drafted By:
M.D.

Designed By:
B.D.

Original Issue:
G.D./C.P. 2003-05-30

Scale:
N.T.S.

Rev: **8**

31-2240

3/4

BILL OF MATERIALS FOR 31-2240			
ITEM NO.	DESCRIPTION	ITEM I.D.	QTY
1	PRECAST CONCRETE 3 PIECE SUBMERSIBLE SPLICE VAULT C/W FRAME, CHECKER PLATES AND SUPPORT BEAMS 1930 X 3050 X 1370 mm DEEP	3540040	1
2	CHANNEL STEEL GALV. 41 mm x 41 mm x 3000 mm (1 ⁵ / ₈ " x 1 ⁵ / ₈ " x 10')	3520220	4
3	ANCHOR STUD BOLT WEDGE 3/8" X 3"	2500057	24
4	WASHER BELLVILLE 1/2"	2530100	24
5	CLAMP CABLE 1 1/4" HOLE THERMOPLASTIC	9663121	24
6	NUT PENTA 1/2"-13 UNC ZINC ALLOY	2520095	24
ASSOCIATED STANDARDS			
7	FRAME, BEAMS AND COVER	STD. 31-8310	1
8	GROUNDING	STD. 18-5400	1
9	VAULT LOCATION NUMBER	STD. 21-3100	1
10	DRAINING STRUCTURES	STD. 31-7100	1

DISTRIBUTION CONSTRUCTION STANDARD
Civil Construction



Approved By:
B.D. 2018-08-28

Drafted By:
M.D.

Designed By:
B.D.

Original Issue:
G.D./C.P. 2003-05-30

Scale:
N.T.S.

Rev: 8

31-2240

4/4

VAULTS

SPLICE VAULT 'B' - 3 PIECE PRECAST
1930 mm (6'-4") x 3050 mm (10'-0") x 1370 (4'-6") mm DEEP

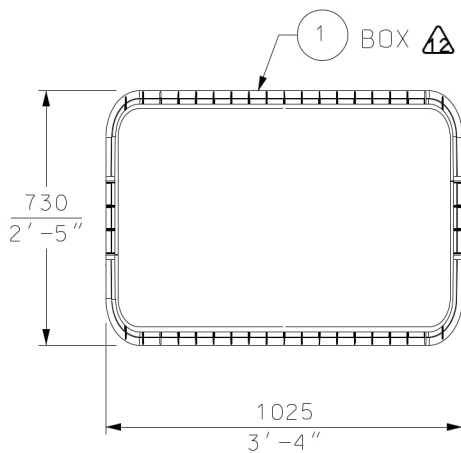

BOX PLAN VIEW

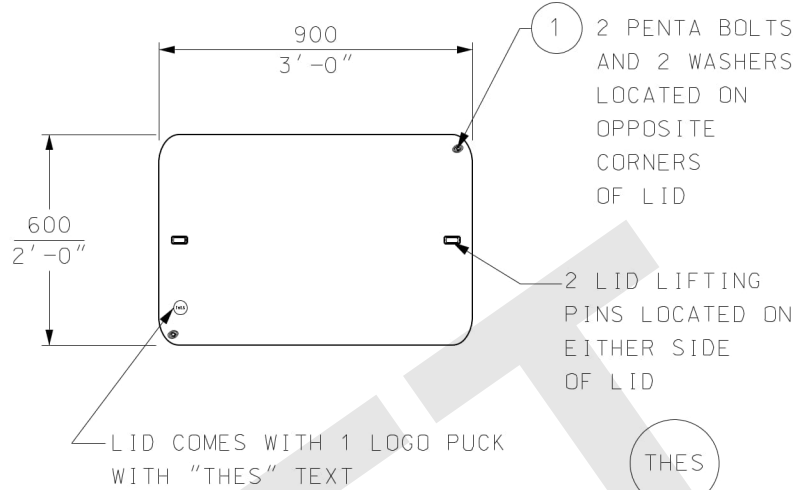

LID PLAN VIEW

COMPOSITE POLYMER LID
WEIGHS 50 LBS

**LOGO PUCK
DETAIL**

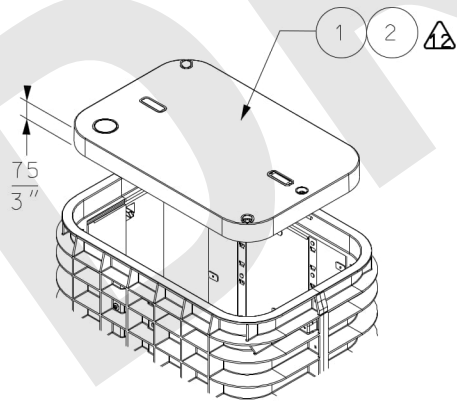

ISOMETRIC VIEW

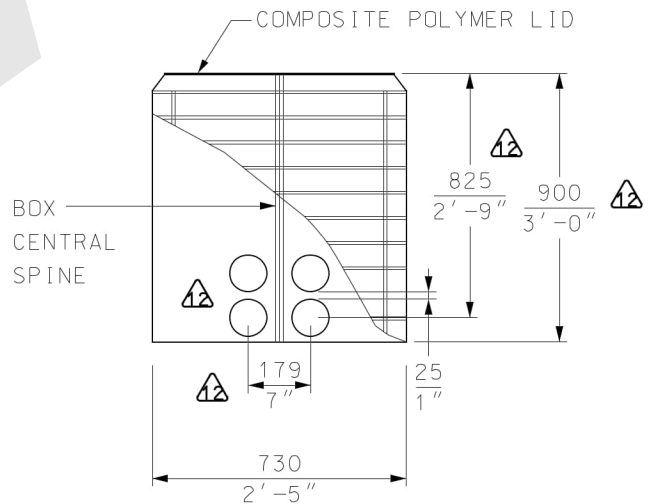

BOX SIDE VIEW - SHORT SIDEWALL

DISTRIBUTION CONSTRUCTION STANDARD
Civil Construction

SPLICE/TAP BOX

TYPE 'A' - FOR SECONDARY CABLES ONLY



Approved By:

Drafted By:
J. D.

Designed By:
B. D.

Original Issue:
G. D. / L. G. 2000-12-19

Scale:
N. T. S.

Rev: **12**

31-3120

1/3

© CERTIFIED BY TORONTO HYDRO STANDARD <STANDARDS@TORONTOHYDRO.COM>, THIS DOCUMENT IS FOR USE BY TORONTO HYDRO AND AUTHORIZED PERSONS ONLY AS PER THE TERMS IN TORONTO HYDRO STANDARD 00-0002.

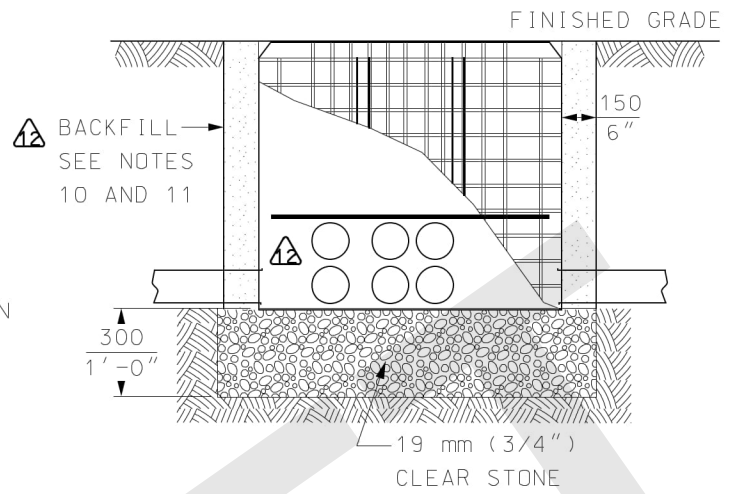
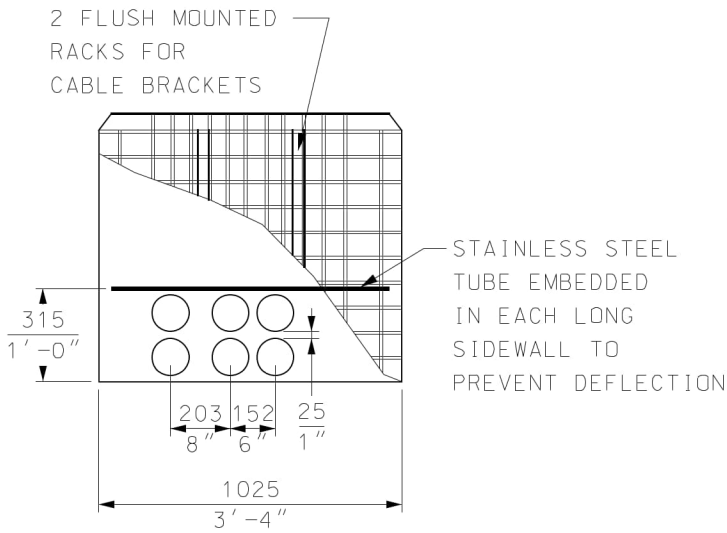

BOX SIDE VIEW - LONG SIDEWALL

BOX SIDE VIEW - INSTALLATION DETAIL



LID DETAIL



CABLE BRACKETS

BOM LEGEND

A	SPLICE/TAP BOX TYPE 'A'
B	REPLACEMENT ACCESSORIES



DISTRIBUTION CONSTRUCTION STANDARD
Civil Construction

Approved By:

Drafted By:
J.D.

Designed By:
B.D.

Original Issue:
G.D./L.G. 2000-12-19

Scale:
N.T.S.

Rev: 12

31-3120

2/3

SPLICE/TAP BOX

TYPE 'A' - FOR SECONDARY CABLES ONLY



BILL OF MATERIALS FOR 31-3120

ITEM NO.	DESCRIPTION	ITEM I.D.	QTY	
			A	B
1	1 - 600X900X900 HDPE BOX 1 - COMPOSITE POLYMER LID 2 - 8 mm PENTA HEAD BOLTS 2 - WASHERS 2 - 4" STEP BRACKETS 2 - 4" HOOK BRACKETS	9665466	1	-
2	LID KIT CW 1-600X900 LID, 2-PENTA BOLTS, 2-RETAINERS, 2-WASHERS	100001694	-	1
3	BOLT DOWN KIT CW - PENTA LAG W/RETAINERS AND WASHERS (2/PACKAGE)	100001689	-	1
4	4" STEP BRACKETS	100001690	-	1
5	4" HOOK BRACKETS	100001691	-	1



* WHEN REQUIRED

NOTES:

- 1) FOR LEGACY LID REPLACEMENTS ONLY, REFER TO FOLLOWING STOCK CODES:
 - COVER GREEN HDPE WITH LOCKING ASSEMBLY: ID# 9656831
 - GREEN EXTENSION RING 75mm: ID# 9662994
 - COVER POLYMER CONCRETE (GREY COLOR) WITH LOCKING ASSEMBLY: ID# 9662431
 - GREY EXTENSION RING 75mm: ID# 9662995
 - PENTA HEAD BOLT LOCKING ASSEMBLY: ID# 9663408
- 2) AS SHOWN, BOX COMES WITH PRE DRILLED 125 mm (5") HOLES ON EACH SIDEWALL. IF REQUIRED A MAX. OF 2 ADDITIONAL HOLES CAN BE DRILLED IN THE SHORT SIDEWALL BY USING A STANDARD HOLE SAW OR A DRILL BIT. AVOID DRILLING HOLES OR CUTTING AT THE FOLLOWING LOCATIONS:
 - THE BOX'S CENTRAL SPINE (LOCATED IN THE SHORT SIDEWALLS),
 - TOP 300 mm (1'-0") OF THE BOX.
- 3) BOX SHALL BE INSTALLED IN GRASSY OR PAVED BOULEVARDS. FOR INSTALLATION IN SIDEWALKS, APPROVAL IS REQUIRED FROM THE CITY OF TORONTO. FOR OPERATIONAL REASONS, BOX SHALL NOT BE INSTALLED IN ROADS, DRIVEWAYS OR AREAS WITH CONSISTENT VEHICULAR TRAFFIC.
- 4) TO REMOVE A FROZEN LID, MANUFACTURER RECOMMENDS HITTING AROUND PENTA BOLT LOCATIONS WITH SLEDGE HAMMER TO LOOSEN BOLTS.
- 5) LIFTING HOOK SHALL BE USED TO REMOVE LID (ITEM ID# 9666054).

INSTALLATION NOTES:

- 6) EXCAVATE 150 mm (6") LARGER THAN THE WIDTH AND LENGTH OF THE BOX.
- 7) EXCAVATE 300 mm (1'-0") DEEPER THAN THE OVERALL DEPTH OF THE BOX. TAMP THE BOTTOM OF THE EXCAVATION TO COMPRESS AND FLATTEN ANY LOOSE SOIL.
- 8) PLACE 300 mm (1'-0") OF 19 mm (3/4") CRUSHED STONE BEDDING OVER THE ENTIRE FLOOR OF THE EXCAVATION. THE CRUSHED STONE SHALL BE FREE OF SOIL AND OTHER ORGANIC MATTER. THIS PREVENTS SETTLEMENT, AIDS IN DRAINAGE, AND PROVIDES A SOLID BEDDING. AS AN ALTERNATIVE, A DRY MIX OF CEMENT AND CRUSHED ROCK IN A 1:10 RATIO MAY BE USED TO FORM A HIGHER STRENGTH BEDDING.
- 9) PLACE THE BOX IN THE EXCAVATION AND LEVEL SO THAT THE BOX IS FLUSH WITH FINISHED GRADE BY ADDING/ADJUSTING THE BEDDING.
- 10) COMPLETE EXCAVATION SHALL BE BACKFILLED WITH UNSHRINKABLE FILL TO WITHIN 100 mm (4") FROM FINISHED GRADE. CARE SHALL BE TAKEN SO NOT TO CAUSE EXCESSIVE DAMAGE TO THE BOX'S CELLULAR RIBS DURING THE BACKFILLING PROCESS.
- 11) BACKFILL THE REMAINING 100 mm (4") TO FINISHED GRADE AS PER SPECIFICATION #CV-CON-01 AND/OR CITY OF TORONTO'S LATEST BACKFILLING REQUIREMENT.

DISTRIBUTION CONSTRUCTION STANDARD
Civil Construction

SPLICE/TAP BOX

TYPE 'A' - FOR SECONDARY CABLES ONLY



Approved By:

Drafted By:
J.D.

Designed By:
B.D.

Original Issue:
G.D./L.G. 2000-12-19

Scale:
N.T.S.

Rev: 12

31-3120

3/3

© CERTIFIED BY TORONTO HYDRO STANDARD <STANDARDS@TORONTOHYDRO.COM>; THIS DOCUMENT IS FOR USE BY TORONTO HYDRO AND AUTHORIZED PERSONS ONLY AS PER THE TERMS IN TORONTO HYDRO STANDARD 00-0002.

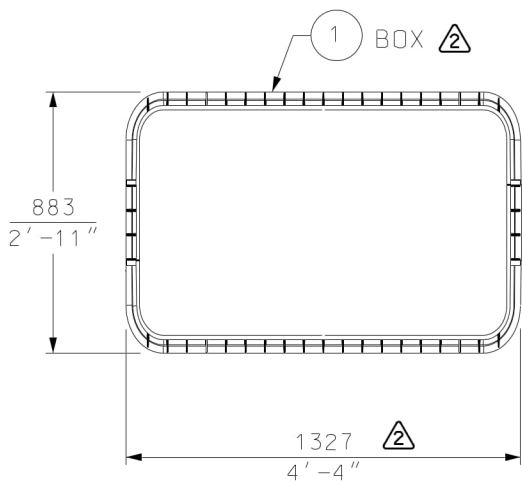

BOX PLAN VIEW

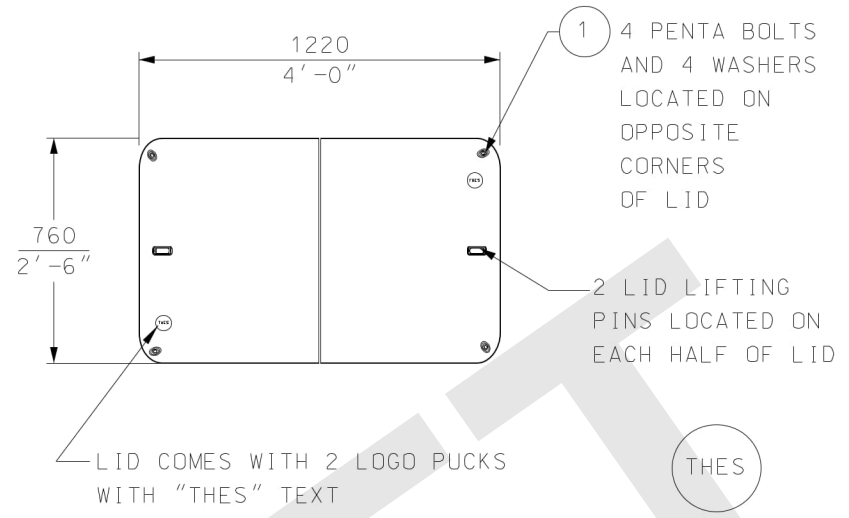

LID PLAN VIEW

LOGO PUCK DETAIL

COMPOSITE POLYMER LID
EACH HALF WEIGHS 50 LBS

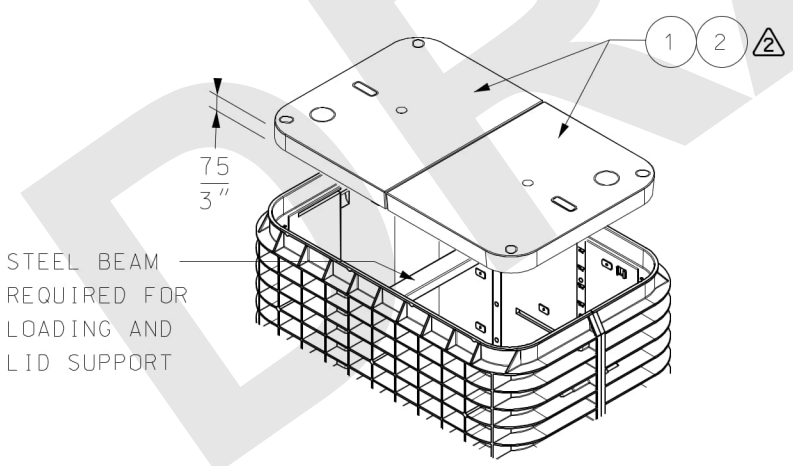

ISOMETRIC VIEW

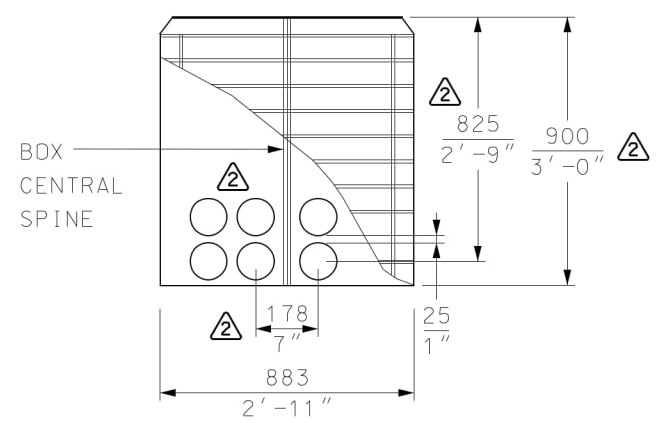

BOX SIDE VIEW - SHORT SIDEWALL

DISTRIBUTION CONSTRUCTION STANDARD Civil Construction		SPLICE/TAP BOX				
Approved By:		TYPE 'B' - FOR PRIMARY OR SECONDARY CABLES				
	Drafted By:	Designed By:	Original Issue:	Scale:	Rev:	
	J. D.	B. D.	B. D. 2019-08-26	N. T. S.	2	
					31-3150	
					1/3	

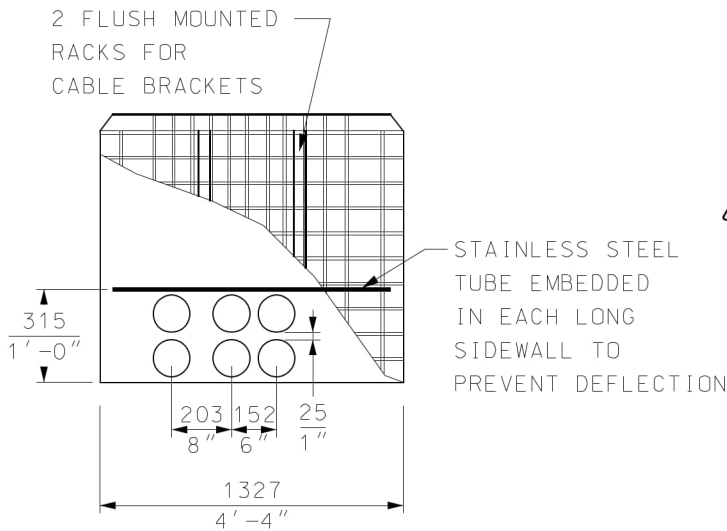

BOX SIDE VIEW - LONG SIDEWALL ⚠

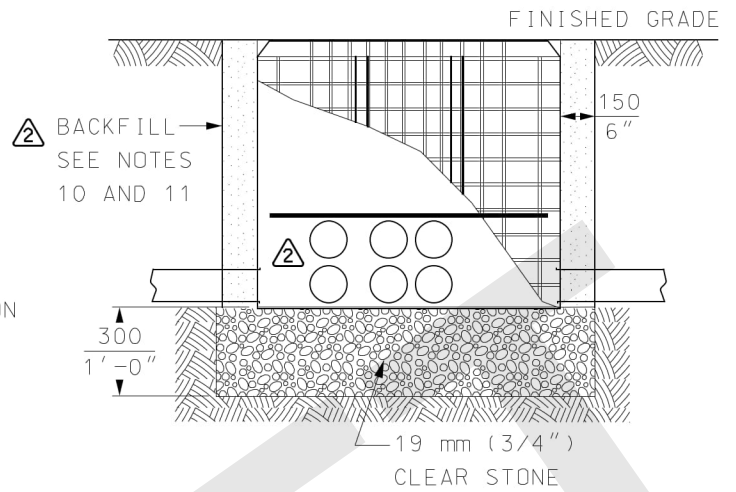

BOX SIDE VIEW - INSTALLATION DETAIL



LID DETAIL

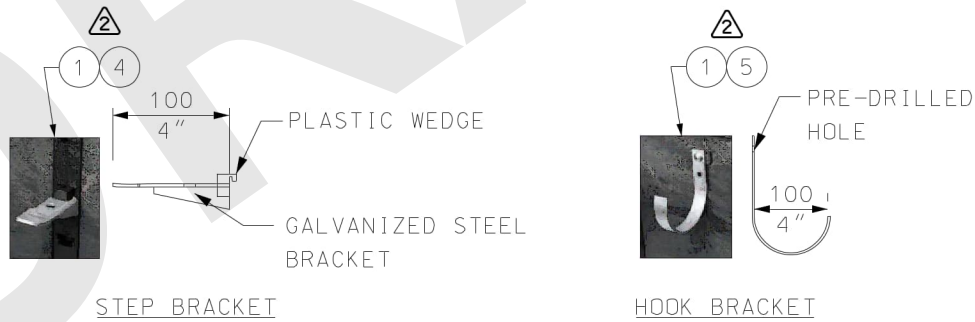

CABLE BRACKETS

BOM LEGEND	
A	SPLICE/TAP BOX TYPE 'B'
B	REPLACEMENT ACCESSORIES



DISTRIBUTION CONSTRUCTION STANDARD
Civil Construction

SPLICE/TAP BOX

TYPE 'B' - FOR PRIMARY OR SECONDARY CABLES



Approved By:

Drafted By:
J.D.

Designed By:
B.D.

Original Issue:
B.D. 2019-08-26





Scale:
N.T.S.

Rev: **2**

31-3150

2/3

BILL OF MATERIALS FOR 31-3150

ITEM NO.	DESCRIPTION	ITEM I.D.	QTY	
			A	B
1	1 - 760x1220x900 mm HDPE BOX  1 - COMPOSITE POLYMER LID 4 - 8 mm PENTA HEAD BOLTS 4 - WASHERS 2 - 4" STEP BRACKETS 2 - 4" HOOK BRACKETS	9665467	1	-
	2 LID KIT CW 1-600X900 LID, 2-PENTA BOLTS, 2-RETAINERS, 2-WASHERS	100001693	-	1
	3 BOLT DOWN KIT CW - PENTA LAG W/RETAINERS AND WASHERS (2/PACKAGE)	100001689	-	1
	4 4" STEP BRACKETS	100001690	-	1
	5 4" HOOK BRACKETS	100001691	-	1

 * WHEN REQUIRED

NOTES:

- 1) FOR LEGACY LID REPLACEMENTS ONLY, REFER TO FOLLOWING STOCK CODES:
 - COVER GREEN HDPE WITH LOCKING ASSEMBLY: ID# 9656868
 - GREEN EXTENSION RING 75mm: ID# 9662996
 - COVER POLYMER CONCRETE (GREY COLOR) WITH LOCKING ASSEMBLY: ID# 9662430
 - GREY EXTENSION RING 75mm: ID# 9662997
 - PENTA HEAD BOLT LOCKING ASSEMBLY: ID# 9663408
-  2) AS SHOWN, BOX COMES WITH PRE DRILLED 125 mm (5") HOLES ON EACH SIDEWALL. IF REQUIRED A MAX. OF 2 ADDITIONAL HOLES CAN BE DRILLED IN ALL SIDEWALLS BY USING A STANDARD HOLE SAW OR A DRILL BIT. AVOID DRILLING HOLES OR CUTTING AT THE FOLLOWING LOCATIONS:
 - THE BOX'S CENTRAL SPINE (LOCATED IN THE SHORT SIDEWALLS),
 - TOP 300 mm (1'-0") OF THE BOX.
- 3) BOX SHALL BE INSTALLED IN GRASSY OR PAVED BOULEVARDS. FOR INSTALLATION IN SIDEWALKS, APPROVAL IS REQUIRED FROM THE CITY OF TORONTO. FOR OPERATIONAL REASONS, BOX SHALL NOT BE INSTALLED IN ROADS, DRIVEWAYS OR AREAS WITH CONSISTENT VEHICULAR TRAFFIC.
- 4) TO REMOVE A FROZEN LID, MANUFACTURER RECOMMENDS HITTING AROUND PENTA BOLT LOCATIONS WITH SLEDGE HAMMER TO LOOSEN BOLTS.
- 5) LIFTING HOOK SHALL BE USED TO REMOVE LID (ITEM ID# 9666054).

INSTALLATION NOTES:

- 6) EXCAVATE 150 mm (6") LARGER THAN THE WIDTH AND LENGTH OF THE BOX.
- 7) EXCAVATE 300 mm (1'-0") DEEPER THAN THE OVERALL DEPTH OF THE BOX. TAMP THE BOTTOM OF THE EXCAVATION TO COMPRESS AND FLATTEN ANY LOOSE SOIL.
- 8) PLACE 300 mm (1'-0") OF 19 mm (3/4") CRUSHED STONE BEDDING OVER THE ENTIRE FLOOR OF THE EXCAVATION. THE CRUSHED STONE SHALL BE FREE OF SOIL AND OTHER ORGANIC MATTER. THIS PREVENTS SETTLEMENT, AIDS IN DRAINAGE, AND PROVIDES A SOLID BEDDING. AS AN ALTERNATIVE, A DRY MIX OF CEMENT AND CRUSHED ROCK IN A 1:10 RATIO MAY BE USED TO FORM A HIGHER STRENGTH BEDDING.
- 9) PLACE THE BOX IN THE EXCAVATION AND LEVEL SO THAT THE BOX IS FLUSH WITH FINISHED GRADE BY ADDING/ADJUSTING THE BEDDING.
- 10) COMPLETE EXCAVATION SHALL BE BACKFILLED WITH UNSHRINKABLE FILL TO WITHIN 100 mm (4") FROM FINISHED GRADE. CARE SHALL BE TAKEN SO NOT TO CAUSE EXCESSIVE DAMAGE TO THE BOX'S CELLULAR RIBS DURING THE BACKFILLING PROCESS.
- 11) BACKFILL THE REMAINING 100 mm (4") TO FINISHED GRADE AS PER SPECIFICATION #CV-CON-01 AND/OR CITY OF TORONTO'S LATEST BACKFILLING REQUIREMENT.

DISTRIBUTION CONSTRUCTION STANDARD
Civil Construction



Approved By:

Drafted By:
J.D.

Designed By:
B.D.

Original Issue:
B.D. 2019-08-26

Scale:
N. T. S.

Rev: **2**

31-3150

3/3

SPLICE/TAP BOX

TYPE 'B' - FOR PRIMARY OR SECONDARY CABLES

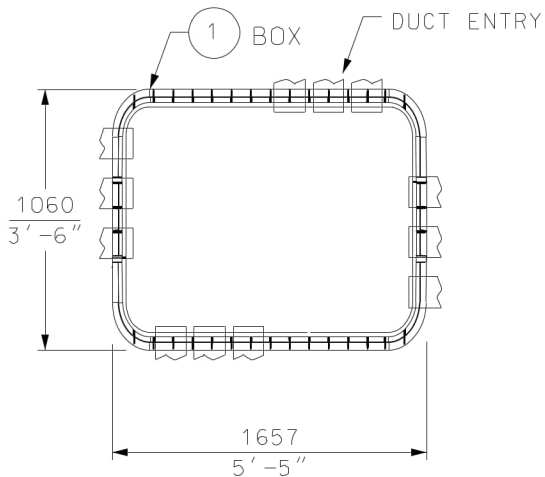

BOX PLAN VIEW ⚠

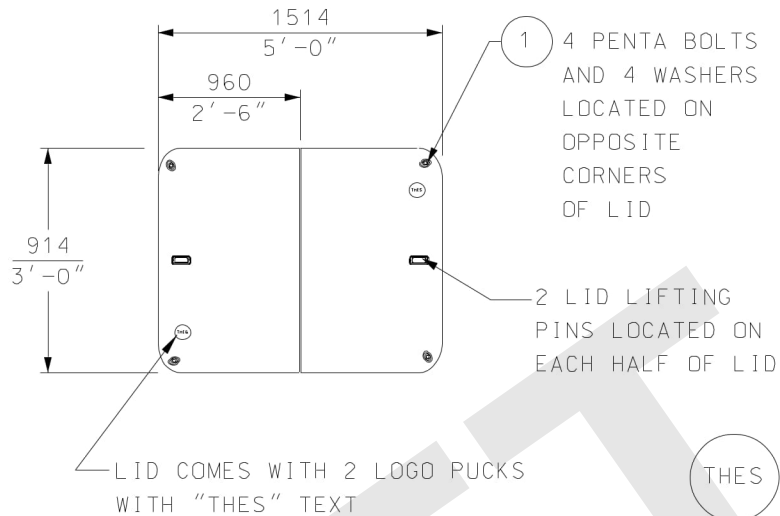

LID PLAN VIEW ⚠
COMPOSITE POLYMER LID



LOGO PUCK DETAIL

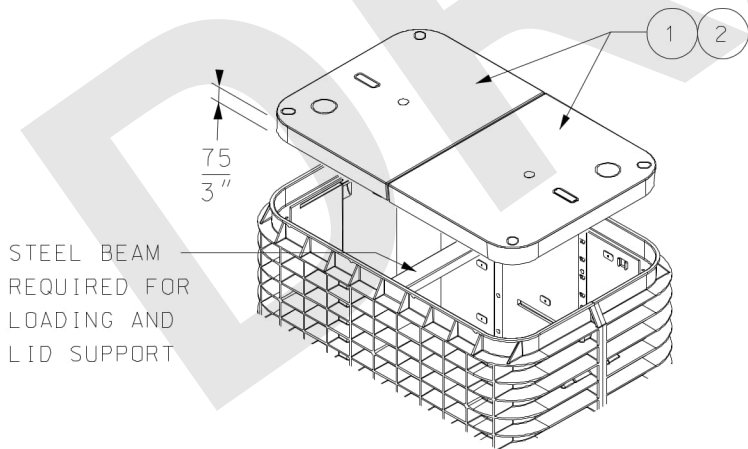

ISOMETRIC VIEW

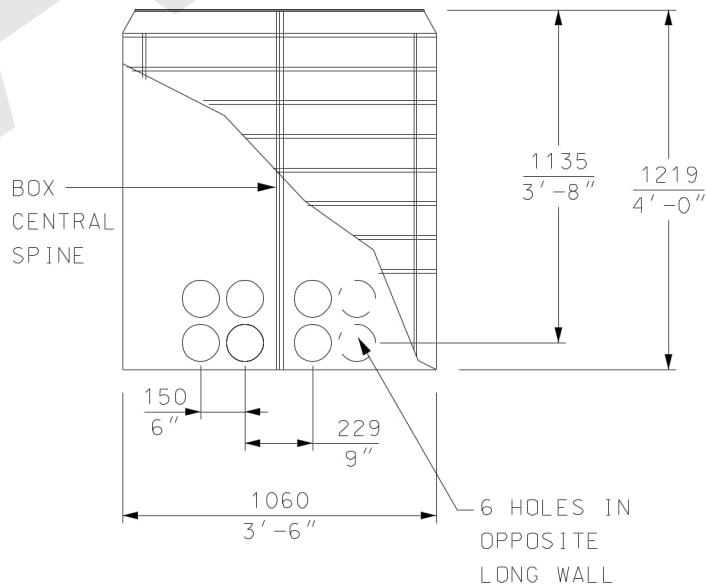

BOX SIDE VIEW - SHORT SIDEWALL

DISTRIBUTION CONSTRUCTION STANDARD
Civil Construction

SPLICE/TAP BOX ⚠

TYPE 'C' - 914 mm (3'-0") x 1514 mm (5'-0") - FOR PRIMARY CABLES



Approved By:

Drafted By:
J.D.

Designed By:
B.D.

Original Issue:
B.D. 2022-01-31

Scale:
N.T.S.

Rev:

1

31-3170

1/3

© CERTIFIED BY TORONTO HYDRO STANDARD <STANDARDS@TORONTOHYDRO.COM>, THIS DOCUMENT IS FOR USE BY TORONTO HYDRO AND AUTHORIZED PERSONS ONLY AS PER THE TERMS IN TORONTO HYDRO STANDARD 00-0002.

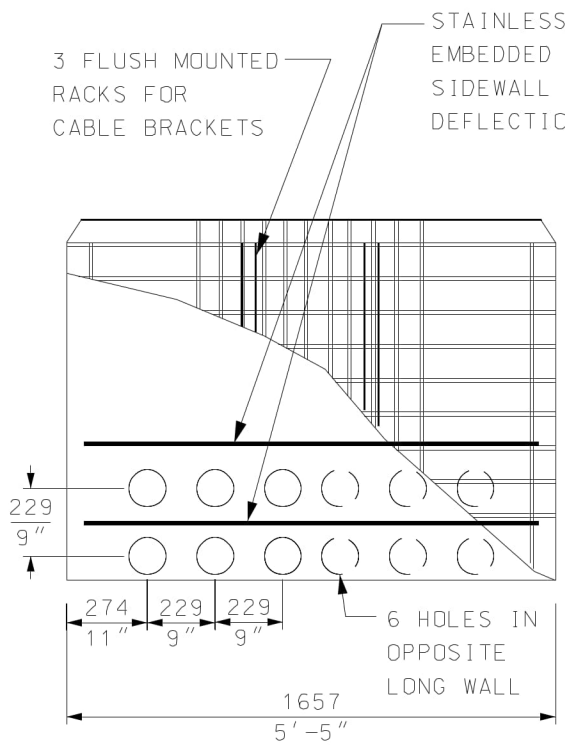

BOX SIDE VIEW ⚠️
LONG SIDEWALL

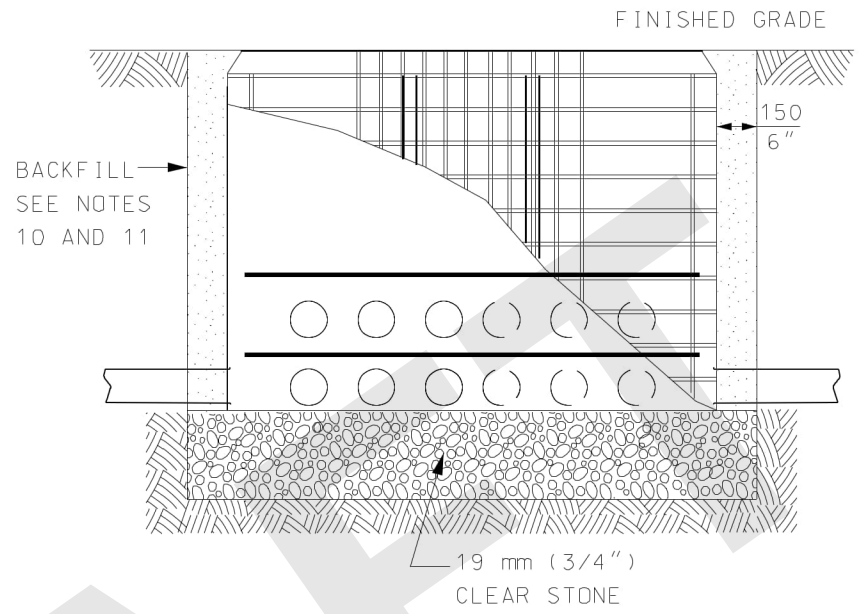

BOX SIDE VIEW
INSTALLATION DETAIL



LID DETAIL

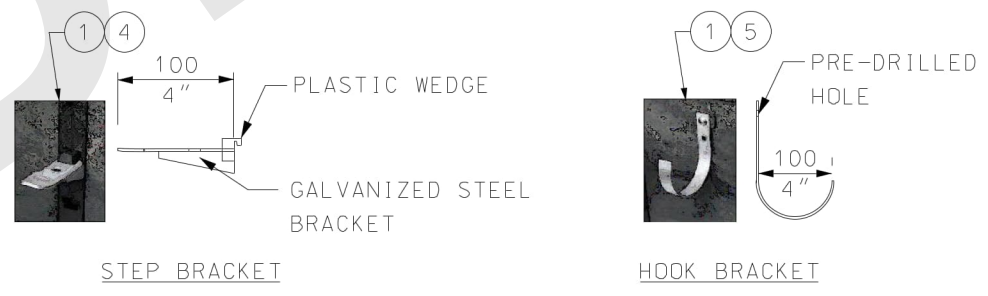

CABLE BRACKETS

DISTRIBUTION CONSTRUCTION STANDARD Civil Construction		⚠️				
		SPLICE/TAP BOX				
		TYPE 'C' - 914 mm (3'-0") x 1514 mm (5'-0") - FOR PRIMARY CABLES				
Approved By:		Original Issue:	Scale:	Rev:		
J. D.	B. D.	B. D. 2022-01-31	N. T. S.	1	31-3170 2/3	

BOM LEGEND	
A	SPLICE/TAP BOX TYPE 'C'
B	REPLACEMENT ACCESSORIES



BILL OF MATERIALS FOR 31-3170				
ITEM NO.	DESCRIPTION	ITEM I.D.	QTY	
			A	B
1	1 - 1060x1657x1219 mm HDPE BOX 1 - COMPOSITE POLYMER LID 4 - 8 mm PENTA HEAD BOLTS 4 - WASHERS 2 - 4" STEP BRACKETS (WITH 2 WEDGES) 2 - 4" HOOK BRACKETS		1	-
2	LID KIT CW 1-915x1514 LID, 2-PENTA BOLTS, 2-RETAINERS, 2-WASHERS		-	1
3	BOLT DOWN KIT CW - PENTA LAG W/RETAINERS AND WASHERS (2/PACKAGE)	100001689	-	1
4	4" STEP BRACKETS	100001690	-	1
5	4" HOOK BRACKETS	100001691	-	1

* WHEN REQUIRED

NOTES:

- FOR LEGACY LID REPLACEMENTS ONLY, REFER TO FOLLOWING STOCK CODES:
 - COVER GREEN HDPE WITH LOCKING ASSEMBLY: ID# 9663405
 - PENTA HEAD BOLT LOCKING ASSEMBLY: ID# 9663408
- AS SHOWN, BOX COMES WITH PRE DRILLED 125 mm (5") HOLES ON EACH SIDEWALL. IF REQUIRED, A MAX. OF 2 ADDITIONAL HOLES CAN BE DRILLED IN ALL SIDEWALLS BY USING A STANDARD HOLE SAW OR A DRILL BIT. AVOID DRILLING HOLES OR CUTTING AT THE FOLLOWING LOCATIONS:
 - THE BOX'S CENTRAL SPINE (LOCATED IN THE SHORT SIDEWALLS).
 - TOP 300 mm (1'-0") OF THE BOX.
- BOX SHALL BE INSTALLED IN GRASSY OR PAVED BOULEVARDS. FOR INSTALLATION IN SIDEWALKS, APPROVAL IS REQUIRED FROM THE CITY OF TORONTO. FOR OPERATIONAL REASONS, BOX SHALL NOT BE INSTALLED IN ROADS, DRIVEWAYS OR AREAS WITH CONSISTENT VEHICULAR TRAFFIC.
- TO REMOVE A FROZEN LID, MANUFACTURER RECOMMENDS HITTING AROUND PENTA BOLT LOCATIONS WITH SLEDGE HAMMER TO LOOSEN BOLTS.
- LIFTING HOOK SHALL BE USED TO REMOVE LID (ITEM ID# 9666054).

INSTALLATION NOTES:

- EXCAVATE 150 mm (6") LARGER THAN THE WIDTH AND LENGTH OF THE BOX.
- EXCAVATE 300 mm (1'-0") DEEPER THAN THE OVERALL DEPTH OF THE BOX. TAMP THE BOTTOM OF THE EXCAVATION TO COMPRESS AND FLATTEN ANY LOOSE SOIL.
- PLACE 300 mm (1' -0") OF 19 mm (3/4") CRUSHED STONE BEDDING OVER THE ENTIRE FLOOR OF THE EXCAVATION. THE CRUSHED STONE SHALL BE FREE OF SOIL AND OTHER ORGANIC MATTER. THIS PREVENTS SETTLEMENT, AIDS IN DRAINAGE, AND PROVIDES A SOLID BEDDING. AS AN ALTERNATIVE, A DRY MIX OF CEMENT AND CRUSHED ROCK IN A 1:10 RATIO MAY BE USED TO FORM A HIGHER STRENGTH BEDDING.
- PLACE THE BOX IN THE EXCAVATION AND LEVEL SO THAT THE BOX IS FLUSH WITH FINISHED GRADE BY ADDING/ADJUSTING THE BEDDING.
- COMPLETE EXCAVATION SHALL BE BACKFILLED WITH UNSHRINKABLE FILL TO WITHIN 100 mm (4") FROM FINISHED GRADE. CARE SHALL BE TAKEN SO NOT TO CAUSE EXCESSIVE DAMAGE TO THE BOX'S CELLULAR RIBS DURING THE BACKFILLING PROCESS.
- BACKFILL THE REMAINING 100 mm (4") TO FINISHED GRADE AS PER SPECIFICATION #CV-CON-01 AND/OR CITY OF TORONTO'S LATEST BACKFILLING REQUIREMENT.

DISTRIBUTION CONSTRUCTION STANDARD Civil Construction		SPLICE/TAP BOX			
Approved By:		TYPE 'C' - 914 mm (3'-0") x 1514 mm (5'-0") - FOR PRIMARY CABLES			
	Drafted By:	Designed By:	Original Issue:	Scale:	Rev:
	J. D.	B. D.	B. D. 2022-01-31	N. T. S.	1
			31-3170		3/3

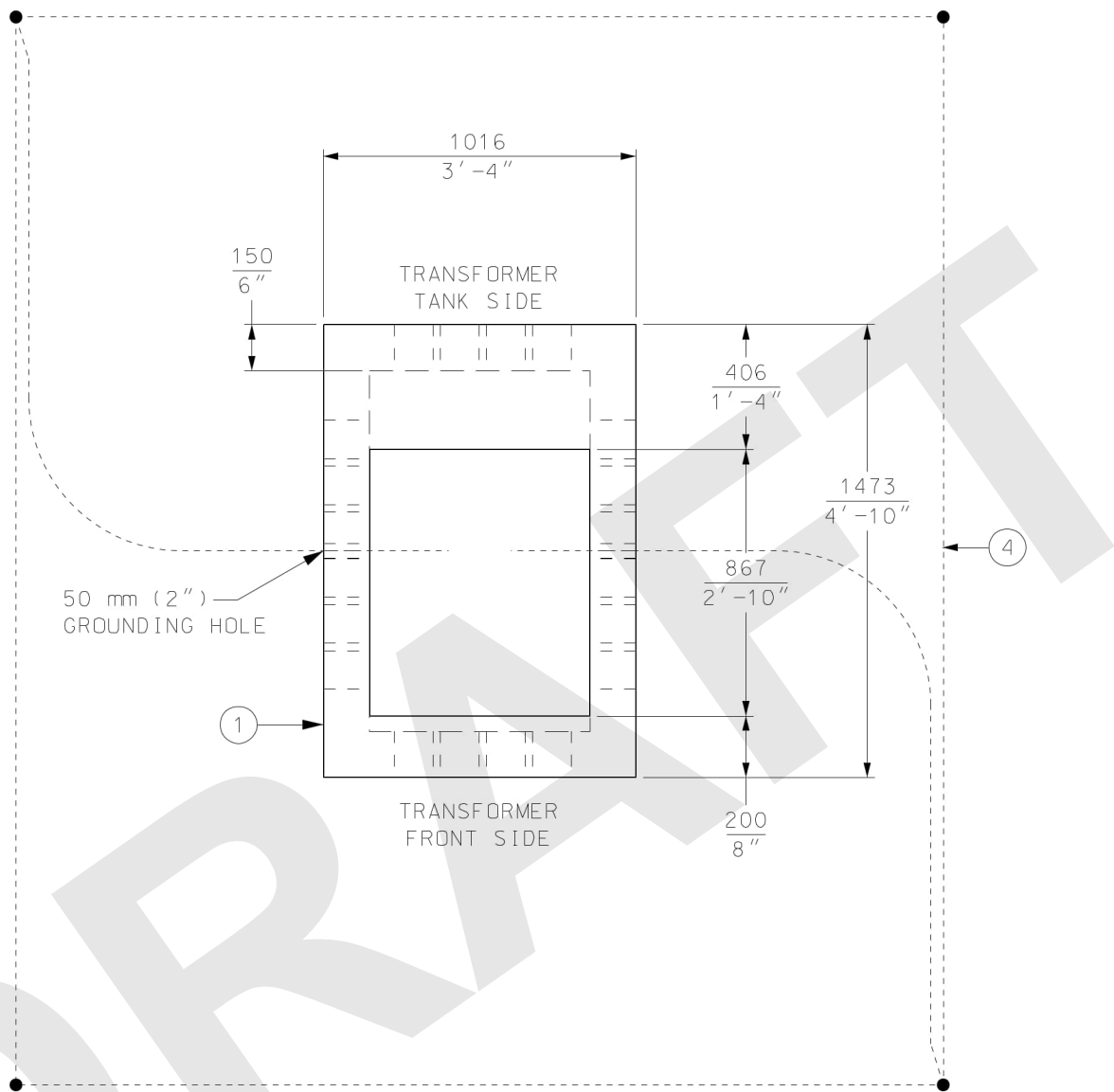

14 PAD-MOUNT PLAN VIEW

DISTRIBUTION CONSTRUCTION STANDARD
Civil Construction



Approved By:

Drafted By:
J.D.

Designed By:
B.D.

Original Issue:
G.D./C.P. 2002-07-11

Scale:
N.T.S.

Rev: 14

31-4020

1/4

PAD-MOUNTS
SINGLE PHASE
1016 mm (3'-4") x 1473 mm (4'-10")



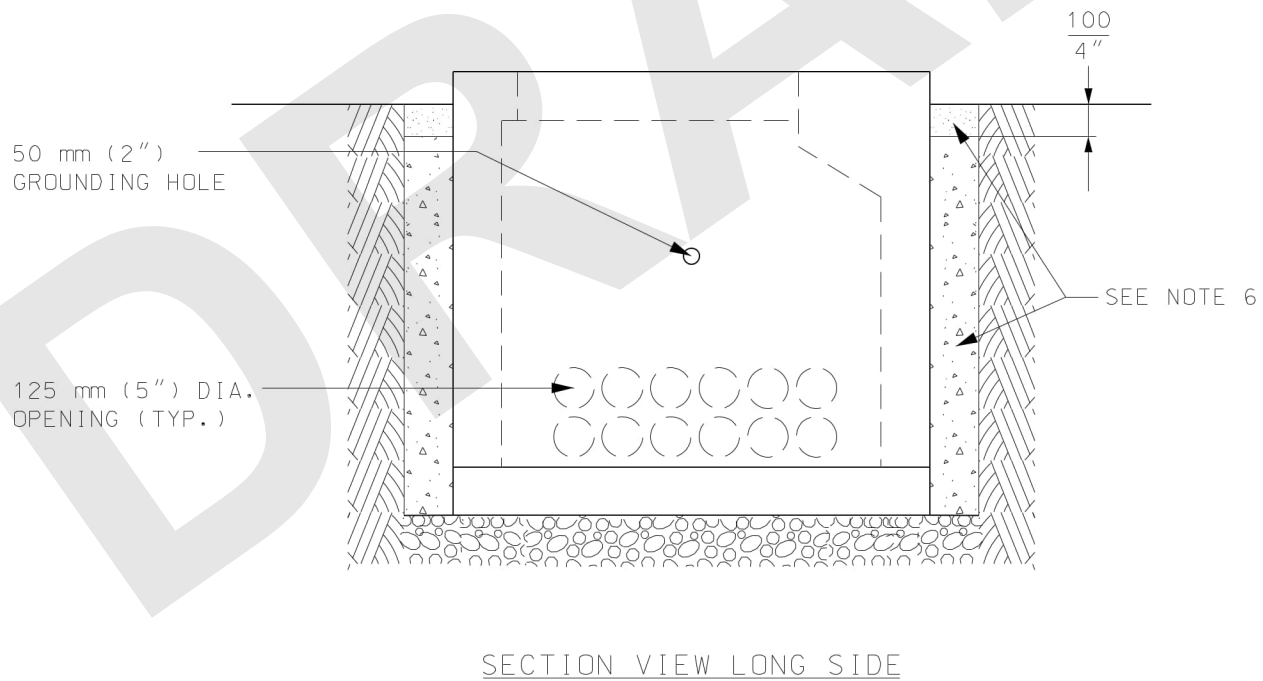
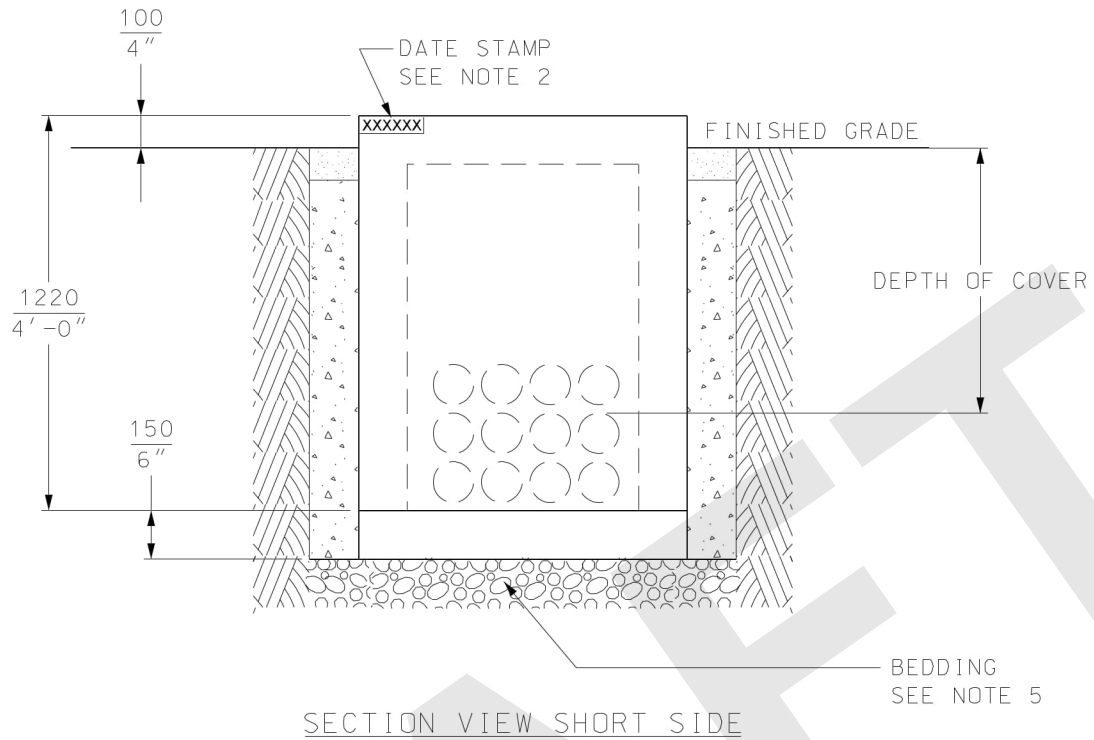

DISTRIBUTION CONSTRUCTION STANDARD
Civil Construction



Approved By:

Drafted By:
J.D.

Designed By:
B.D.

Original Issue:
G.D./C.P. 2002-07-11

PAD-MOUNTS
SINGLE PHASE

1016 mm (3'-4") x 1473 mm (4'-10")

Scale:
N.T.S.

Rev: 14

31-4020

2/4



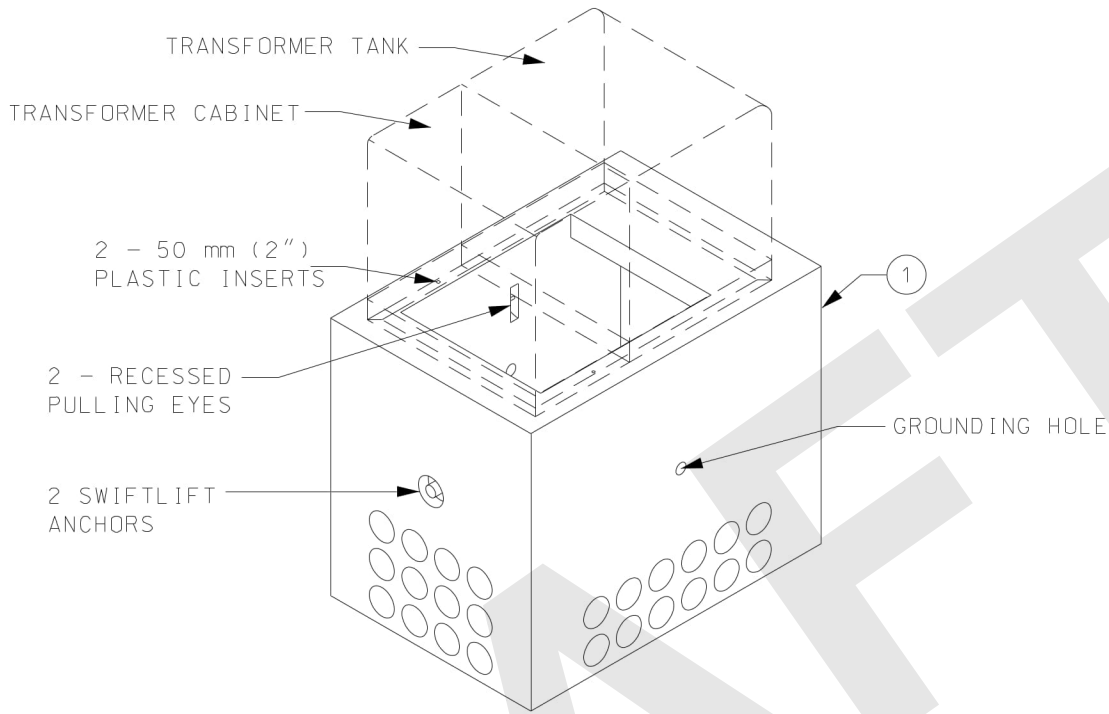

14 PAD ISOMETRIC VIEW

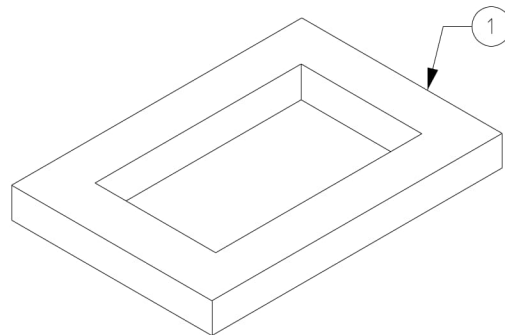
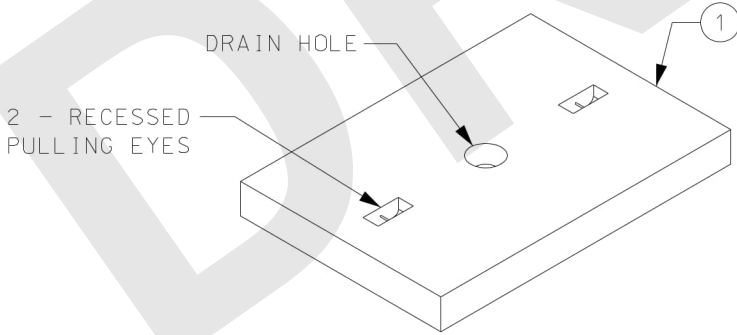

BOTTOM SLAB ISOMETRIC VIEW

DISTRIBUTION CONSTRUCTION STANDARD
Civil Construction



Approved By:

Drafted By:
J. D.

Designed By:
B. D.

Original Issue:
G. D. / C. P. 2002-07-11

PAD-MOUNTS
SINGLE PHASE
1016 mm (3'-4") x 1473 mm (4'-10")

Scale:
N. T. S.

Rev: **14**

31-4020

3/4





BILL OF MATERIALS FOR 31-4020			
ITEM NO.	DESCRIPTION	ITEM I.D.	QTY A
1	PAD-MOUNT WITH BOTTOM SLAB 1016 (3'-4") X 1473 (4'-10")	100002162	1
ASSOCIATED STANDARDS			
2	GUARD POSTS (BOLLARDS)	STD. 31-4080	1
3	CLEARANCE ZONE	STD. 31-4100	1
4	GROUNDING REQUIREMENTS	STD. 18-5500	1

NOTES:

MATERIALS:

- 1) CONCRETE SHALL HAVE A MIN. 28-DAY COMPRESSIVE STRENGTH OF 35 MPa. CONCRETE PRODUCTION AND PLACEMENT SHALL CONFORM TO LATEST CSA-A23.1. ALL TESTING SHALL CONFORM TO LATEST CSA-A23.2.
- 2) MANUFACTURER SHALL ADD DATE OF MANUFACTURE STAMP ON ALL PRECAST UNITS.
- 3) CONCRETE EXPOSURE CLASSIFICATION SHALL BE C-1.
- 4) ALL REINFORCING TO CONFORM TO LATEST CSA STANDARD G30.18, Fy = 400 MPa.

INSTALLATION:

- 5) PLACE 19 mm (3/4") CLEAR STONE BEDDING ON UNDISTURBED SOIL CAPABLE OF SUSTAINING 175 kPa AND COMPACT TO 98% STANDARD PROCTOR DENSITY.
- 6) EXCAVATION SHALL BE BACKFILLED WITH UNSHRINKABLE FILL TO WITHIN 100 MM (4") FROM FINISHED GRADE. BACKFILL THE REMAINING 100 MM (4") TO FINISHED GRADE AS PER TORONTO HYDRO CIVIL SPECIFICATION CV-CON-01.
- 7) FOR VEHICULAR TRAFFIC REFER TO GUARD POSTS (BOLLARDS) STD. 31-4080.
- 8) FOR CLEARANCE ZONE AROUND PAD-MOUNT REFER TO STD. 31-4100.
- 9) PAD-MOUNT LOCATION SHALL BE KEPT CLEAR OF OBSTRUCTIONS FOR ACCESS BY TORONTO HYDRO PERSONNEL AND EQUIPMENT.
- 10) UNUSED CABLE ENTRY DUCTS SHALL BE PLUGGED WITH DUCT PLUGS AND PARGED PRIOR TO BACKFILLING.
- 11) CONTRACTOR SHALL PLUG GROUNDING HOLES AND PARGED PRIOR TO BACKFILLING.
- 12) PRECAST UNITS ARE DELIVERED BY CRANE-EQUIPPED TRUCKS. EXCAVATION MUST BE READY, SAFE AND ACCESSIBLE FOR UNLOADING FROM THE REAR OF THE TRUCK. MIN. OVERHEAD CLEARANCE OF 5.5 m (18'-0") IS REQUIRED. CONTRACTOR SHALL ASSIST SUPPLIER IN LOWERING THE UNITS INTO EXCAVATION.

DISTRIBUTION CONSTRUCTION STANDARD
Civil Construction

PAD-MOUNTS
SINGLE PHASE
1016 mm (3'-4") x 1473 mm (4'-10")



Approved By:

Drafted By:
J.D.

Designed By:
B.D.

Original Issue:
G.D./C.P. 2002-07-11

Scale:
N.T.S.

Rev: **14**

31-4020

4/4

© CERTIFIED BY TORONTO HYDRO STANDARD <STANDARDS@TORONTOHYDRO.COM>; THIS DOCUMENT IS FOR USE BY TORONTO HYDRO AND AUTHORIZED PERSONS ONLY AS PER THE TERMS IN TORONTO HYDRO STANDARD 00-0002.

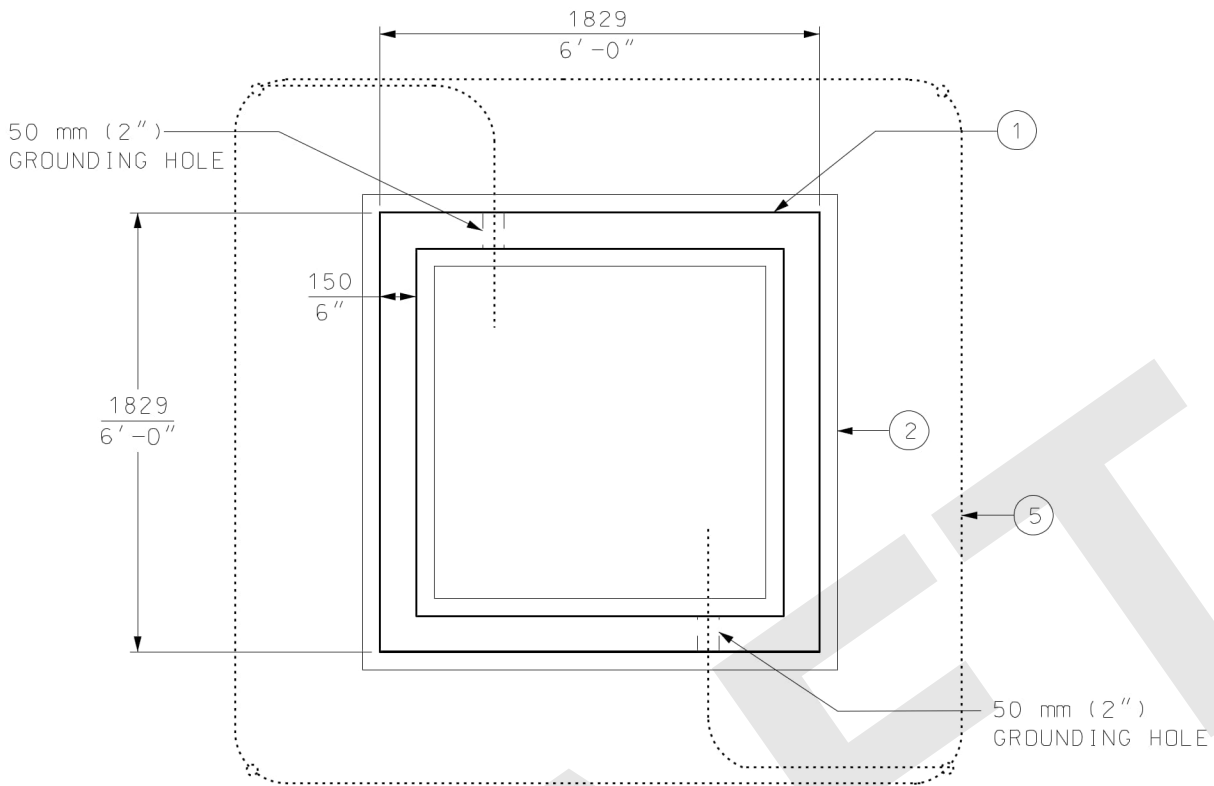

**PAD-MOUNT AND FOOTING
PLAN VIEW**

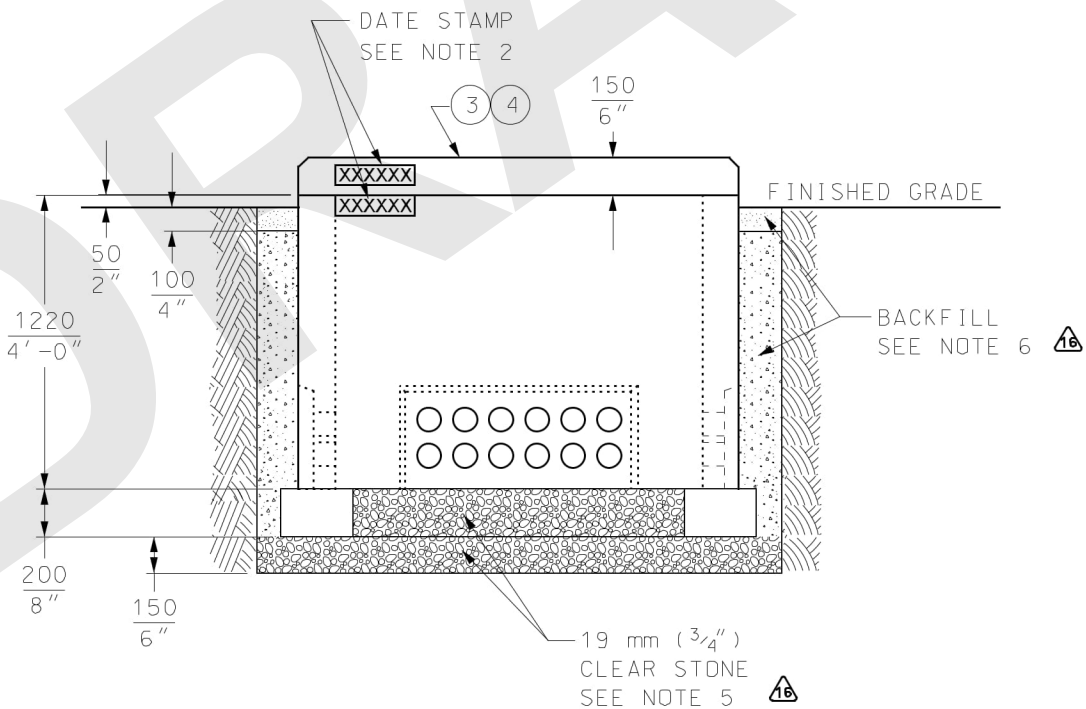

SECTION VIEW

DISTRIBUTION CONSTRUCTION STANDARD
Civil Construction



Approved By:

Drafted By:
J. D.

Designed By:
B. D.

Original Issue:
C. P. / G. D. 2002-07-11

Scale:
N. T. S.

Rev. 16

31-4030

1/3

PAD-MOUNTS
THREE PHASE PRECAST PAD-MOUNT
1830 mm (6'-0") x 1830 mm (6'-0")



© CERTIFIED BY TORONTO HYDRO STANDARD <STANDARDS@TORONTOHYDRO.COM>, THIS DOCUMENT IS FOR USE BY TORONTO HYDRO AND AUTHORIZED PERSONS ONLY AS PER THE TERMS IN TORONTO HYDRO STANDARD 00-0002.

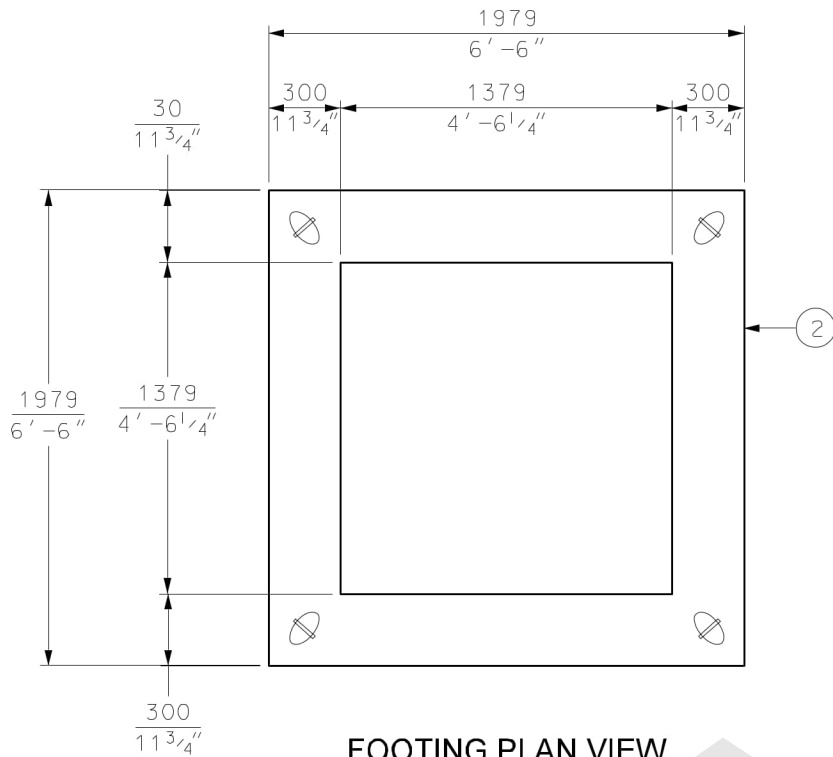

FOOTING PLAN VIEW

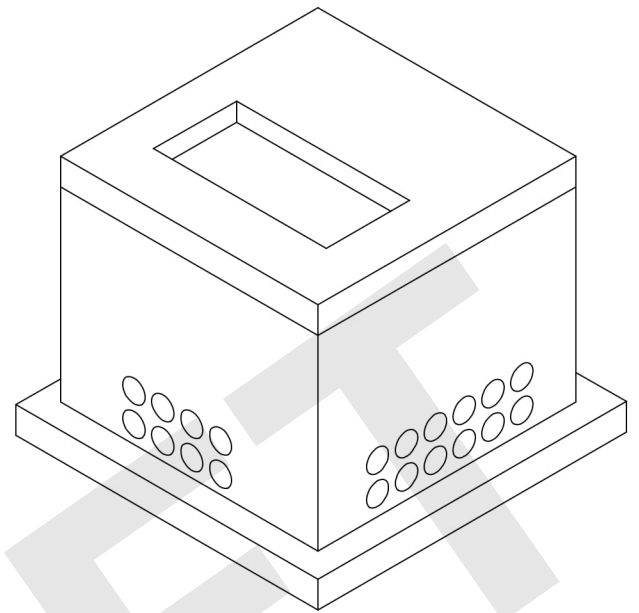

ISOMETRIC VIEW

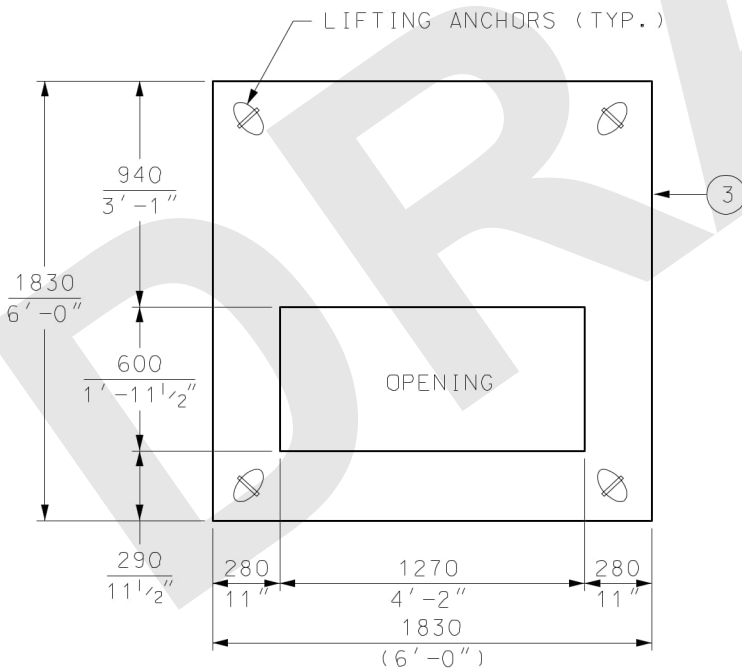

**THREE PHASE TRANSFORMER LID
PLAN VIEW**

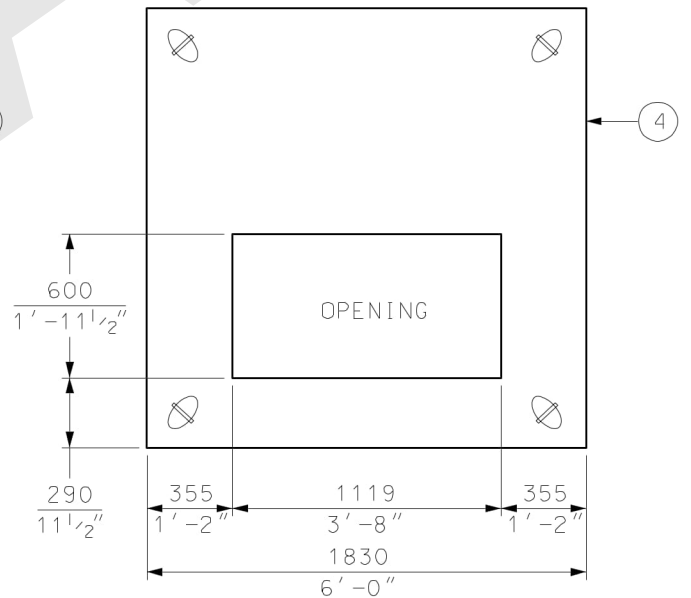

**METERING LID
PLAN VIEW**

DISTRIBUTION CONSTRUCTION STANDARD
Civil Construction



Approved By:

Drafted By:
J. D.

Designed By:
B. D.

Original Issue:
C. P. / G. D. 2002-07-11

Scale:
N. T. S.

Rev.

16

31-4030

2/3

PAD-MOUNTS
THREE PHASE PRECAST PAD-MOUNT
1830 mm (6'-0") x 1830 mm (6'-0")



BILL OF MATERIALS FOR 31-4030

ITEM NO.	DESCRIPTION	ITEM I.D.	QTY
1	FOUNDATION PAD 1830 mm x 1830 mm x 1220 mm DEEP	3540014	1
2	STRIP FOOTING (FLOOR) 1980 mm x 1980 mm x 200 mm, 300 mm WIDE	9656479	1
3	LID (COVER) 1830 mm x 1830 mm x 150 mm DEEP - FOR THREE PHASE TRANSFORMER PAD	3540022	1
4	LID (COVER) 1830 mm X 1830 mm X 150 mm - FOR THREE PHASE METERING PAD	9662541	1
ASSOCIATED STANDARDS			
5	GUARD POSTS (BOLLARDS)	STD. 31-4080	1
6	CLEARANCE ZONE	STD. 31-4100	1
7	GROUNDING REQUIREMENTS	STD. 18-5500	1

NOTES:

MATERIALS: 

- 1) CONCRETE SHALL HAVE A MINIMUM 28-DAY COMPRESSIVE STRENGTH OF 35 MPa. CONCRETE PRODUCTION AND PLACEMENT SHALL CONFORM TO LATEST EDITION OF CSA-A23.1. ALL TESTING SHALL CONFORM TO LATEST CSA-A23.2.
- 2) MANUFACTURER SHALL ADD DATE OF MANUFACTURE STAMP ON ALL PRECAST UNITS.
- 3) CONCRETE EXPOSURE CLASSIFICATION SHALL BE C-1.
- 4) ALL REINFORCING TO CONFORM TO LATEST CSA STANDARD G30.18, Fy = 400 MPa.

INSTALLATION:

- 5) PLACE 19 mm (³/₄") CLEAR STONE BEDDING ON UNDISTURBED SOIL CAPABLE OF SUSTAINING 175 kPa AND COMPACT TO 98% STANDARD PROCTOR DENSITY.
- 6) EXCAVATION SHALL BE BACKFILLED WITH UNSHRINKABLE FILL TO WITHIN 100 MM (4") FROM FINISHED GRADE. BACKFILL THE REMAINING 100 MM (4") TO FINISHED GRADE AS PER TORONTO HYDRO CIVIL SPECIFICATION CV-CON-01.
- 7) FOR VEHICULAR TRAFFIC REFER TO GUARD POSTS (BOLLARDS) STD. 31-4080.
- 8) PAD-MOUNT LOCATION SHALL BE KEPT CLEAR OF OBSTRUCTIONS FOR ACCESS BY TORONTO HYDRO PERSONNEL AND EQUIPMENT.
- 9) UNUSED CABLE ENTRY DUCTS SHALL BE PLUGGED WITH DUCT PLUGS AND PARGED PRIOR TO BACKFILLING.
- 10) CONTRACTOR SHALL PLUG GROUNDING HOLES AND PARGED PRIOR TO BACKFILLING. CONTRACTOR SHALL PLUG TOP SLAB LIFTING ANCHOR OPENINGS WITH CAULKING PRIOR TO PLACEMENT OF TRANSFORMER.
- 11) PRECAST UNITS SHALL BE DELIVERED BY CRANE-EQUIPPED TRUCKS. EXCAVATION SHALL BE READY, SAFE AND ACCESSIBLE FOR UNLOADING FROM THE REAR OF THE TRUCK. MINIMUM OVERHEAD CLEARANCE OF 5500 mm (18'-0") IS REQUIRED. CONTRACTOR SHALL ASSIST SUPPLIER IN LOWERING THE PRECAST UNITS INTO EXCAVATION.
- 12) CUSTOMER TO PROVIDE 3000 mm (10'-0") OF FLAT LEVEL GROUND SURFACE ON OPERATING SIDE (IN-FRONT) OF TRANSFORMER FOR OPERATIONAL NEEDS.

DISTRIBUTION CONSTRUCTION STANDARD
Civil Construction



Approved By:

Drafted By:
J. D.

Designed By:
B. D.

Original Issue:
C. P. / G. D. 2002-07-11

Scale:
N. T. S.

Rev:

16

31-4030

3/3

PAD-MOUNTS
THREE PHASE PRECAST PAD-MOUNT
1830 mm (6'-0") x 1830 mm (6'-0")



© CERTIFIED BY TORONTO HYDRO STANDARD <STANDARDS@TORONTOHYDRO.COM>, THIS DOCUMENT IS FOR USE BY TORONTO HYDRO AND AUTHORIZED PERSONS ONLY AS PER THE TERMS IN TORONTO HYDRO STANDARD 00-0002.

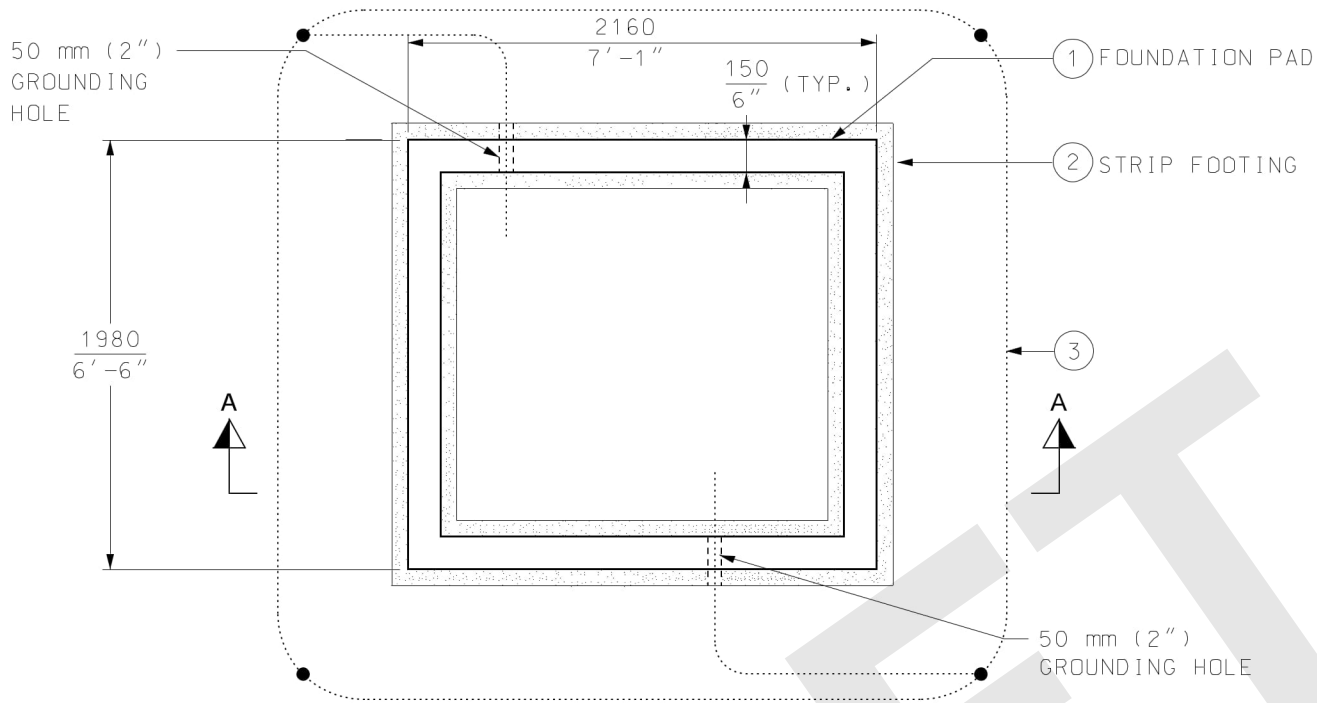

PLAN VIEW

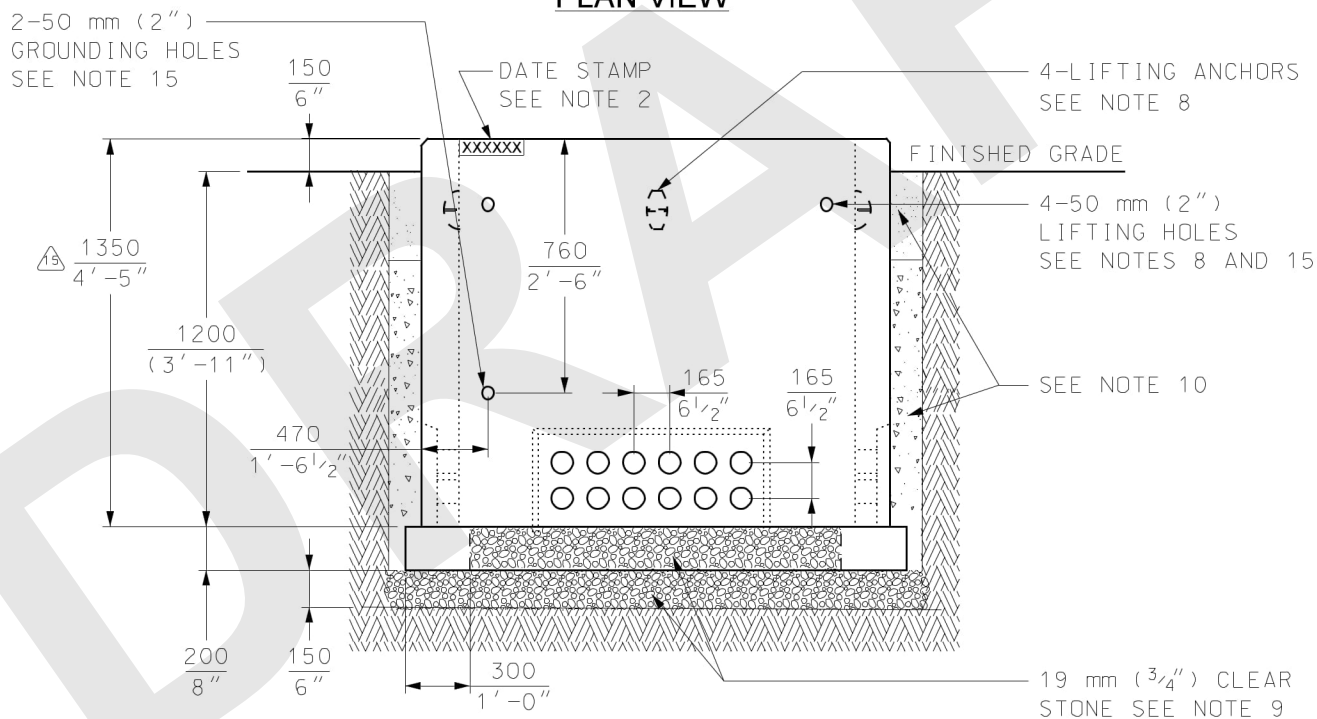

SECTION 'A-A'

BILL OF MATERIALS FOR 31-4050			
ITEM NO.	DESCRIPTION	ITEM I.D.	QTY A
1	FOUNDATION PAD 1980 mm x 2160 mm x 1350 mm DEEP	3540024	1
2	STRIP FOOTING (FLOOR) 2130 mm x 2310 mm x 200 mm, 300 mm WIDE	9656481	1
ASSOCIATED STANDARDS			
3	GROUNDING REQUIREMENTS	STD. 18-5500	1

DISTRIBUTION CONSTRUCTION STANDARD
Civil Construction



Approved By:
B. D. 2020-09-25

Drafted By: B. D.
Designed By: B. D.

Original Issue:
G. D. / C. P. 2002-07-11

Scale:
N. T. S.

Rev: 15

31-4050

1/2

PAD-MOUNTS
THREE PHASE PMH 9/11 SWITCHGEAR
1980 mm x 2160 mm x 1350 mm

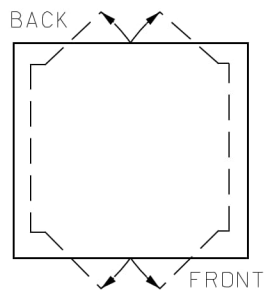

PAD DETAIL

* DOORS TO BE ON LONGER SIDES

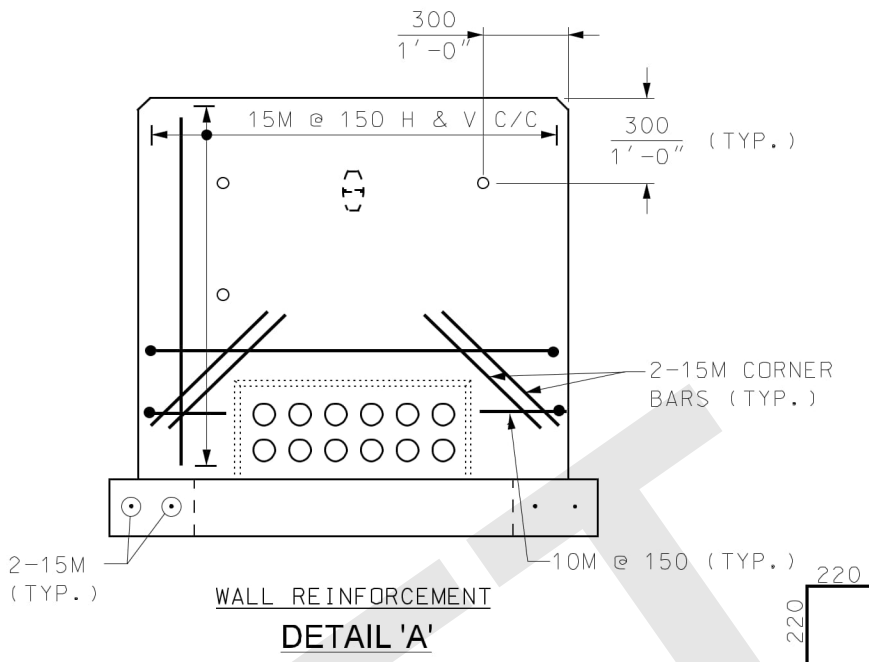

NOTES:

MATERIALS:

- 1) CONCRETE SHALL HAVE A MIN. 28-DAY COMPRESSIVE STRENGTH OF 35 MPa. CONCRETE PRODUCTION AND PLACEMENT SHALL CONFORM TO LATEST CSA-A23.1. ALL TESTING SHALL CONFORM TO LATEST CSA-A23.2.
- 2) MANUFACTURER SHALL ADD DATE OF MANUFACTURE STAMP ON ALL PRECAST UNITS.
- 3) EXPOSURE CLASSIFICATION TO FREEZING AND THAWING IN A SATURATED CONDITION BUT WITH NO CHLORIDES SHALL BE F-1.
- 4) ALL REINFORCING TO CONFORM TO LATEST CSA STANDARD G30.18, Fy = 400 MPa.
- 5) CONCRETE COVER ON PRECAST STRIP FOOTING SHALL BE 50 mm (2"), ALL OTHERS SHALL BE 30 mm (1 1/4"). ALL EXPOSED EDGES SHALL HAVE 25 mm (1") CHAMFER.
- 6) PROVIDE 90° STANDARD HOOK FOR WALL HORIZONTAL REINFORCING BARS.
- 7) 4 - 13 mm (1/2") THREADED INSERTS FOR TRANSFORMER MOUNTING SHALL BE ADDED. THE INSERTS TO BE PLUGGED BY THE MANUFACTURER TO PREVENT ENTRY OF FOREIGN MATTER DURING TRANSIT.
- 8) LIFTING HOLES CAN BE INSTALLED IN FOUNDATION WALLS FOR MANUFACTURER'S LIFTING PREFERENCE. IN ADDITION, 4-LIFTING ANCHORS FOR LIFTING PURPOSES SHALL BE PROVIDED ON THE INSIDE OF ALL FOUNDATION WALLS AND ON TOP OF STRIP FOOTING AS SHOWN IN THIS STANDARD. LIFTING ANCHORS SHALL BE GALVANIZED. LIFTING ANCHORS SHALL BE CAPABLE OF LIFTING THE PRECAST UNITS AND THIS SHALL BE CERTIFIED BY MANUFACTURER'S PROFESSIONAL ENGINEER.

INSTALLATION:

- 9) PLACE 19 mm (3/4") CLEAR STONE BEDDING ON UNDISTURBED SOIL CAPABLE OF SUSTAINING 75 kPa AND COMPACT TO 98% STANDARD PROCTOR DENSITY.
- 10) EXCAVATION SHALL BE BACKFILLED TO FINISHED GRADE AS PER TORONTO HYDRO CIVIL SPECIFICATION CV-CON-01 CLAUSE 5.1.17 AND/OR CITY OF TORONTO'S LATEST BACKFILLING REQUIREMENT.
- 11) TORONTO HYDRO INSPECTOR SHALL BE PRESENT DURING THE INSTALLATION, 24-HOUR NOTICE IS REQUIRED PRIOR TO STARTING THE INSTALLATION.
- 12) FOR VEHICULAR TRAFFIC REFER TO GUARD POSTS (BOLLARDS) STD. 31-4080.
- 13) PAD-MOUNT LOCATION SHALL BE KEPT CLEAR OF OBSTRUCTIONS FOR ACCESS BY TORONTO HYDRO PERSONNEL AND EQUIPMENT.
- 14) UNUSED CABLE ENTRY DUCTS SHALL BE PLUGGED WITH DUCT PLUGS AND PARGED PRIOR TO BACKFILLING.
- 15) CONTRACTOR TO PLUG ALL HOLES (LIFTING AND GROUNDING) AND PARGED PRIOR TO BACKFILLING.
- 16) PRECAST UNITS ARE DELIVERED BY CRANE-EQUIPPED TRUCKS. EXCAVATION MUST BE READY, SAFE AND ACCESSIBLE FOR UNLOADING FROM THE REAR OF THE TRUCK. MIN. OVERHEAD CLEARANCE OF 5.5 m (18'-0") IS REQUIRED. CONTRACTOR SHALL ASSIST SUPPLIER IN LOWERING THE UNITS INTO EXCAVATION.
- 17) WHEN LOCATING PAD-MOUNT, A 3.0 m (10'-0") AREA OF FLAT GROUND SURFACE IS REQUIRED INFRONT OF THE OPERATING SIDE (DOOR SIDE) OF TRANSFORMER FOR OPERATIONAL NEEDS.
- 18) THE FOUNDATION SHALL BE ORIENTED WITH THE LONG SIDE (DOOR SIDE OF SWITCHGEAR) PARALLEL TO THE CURB. FOR SCADA-OPERATED SWITCHGEARS ENSURE THAT LOW VOLTAGE AND SWITCHING COMPARTMENTS ARE NOT IN CONFLICT WITH VEHICULAR AND PEDESTRIAN TRAFFIC.

DISTRIBUTION CONSTRUCTION STANDARD
Civil Construction

PAD-MOUNTS
THREE PHASE PMH 9/11 SWITCHGEAR
1980 mm x 2160 mm x 1350 mm



Approved By:
B.D. 2020-09-25

Drafted By: B.D.
Designed By: B.D.

Original Issue:
G.D./C.P. 2002-07-11

Scale:
N.T.S.

Rev: 15

31-4050

2/2

© CERTIFIED BY TORONTO HYDRO STANDARD <STANDARDS@TORONTOHYDRO.COM>; THIS DOCUMENT IS FOR USE BY TORONTO HYDRO AND AUTHORIZED PERSONS ONLY AS PER THE TERMS IN TORONTO HYDRO STANDARD 00-0002.

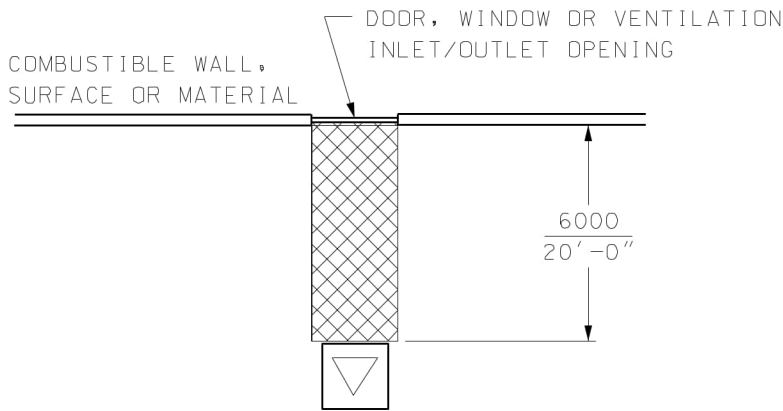

DETAIL 'A' - PLAN VIEW

SEE NOTE 2A

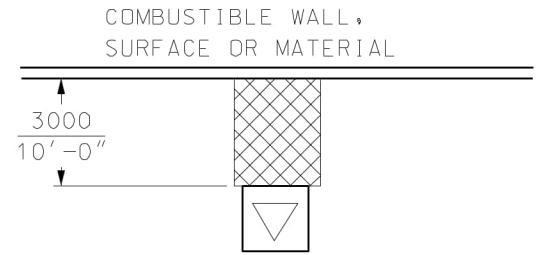

DETAIL 'B' - PLAN VIEW

SEE NOTE 2B

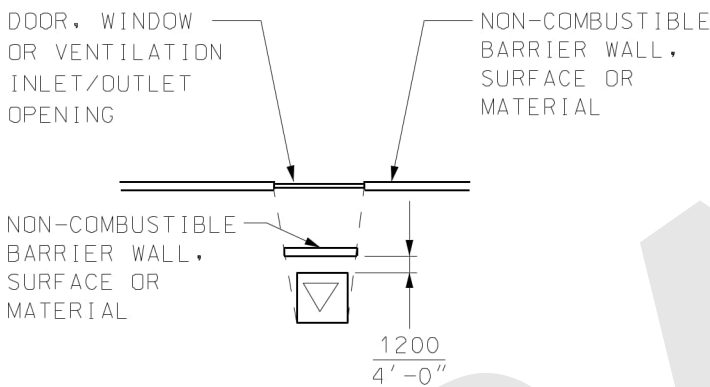

DETAIL 'C' - PLAN VIEW

SEE NOTE 2C

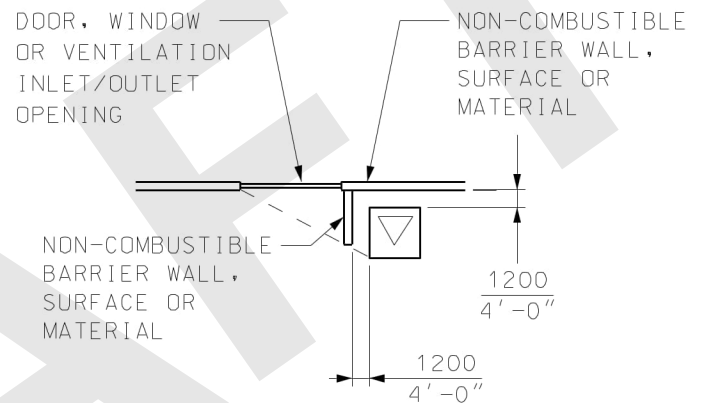

DETAIL 'D' - PLAN VIEW

SEE NOTE 2C

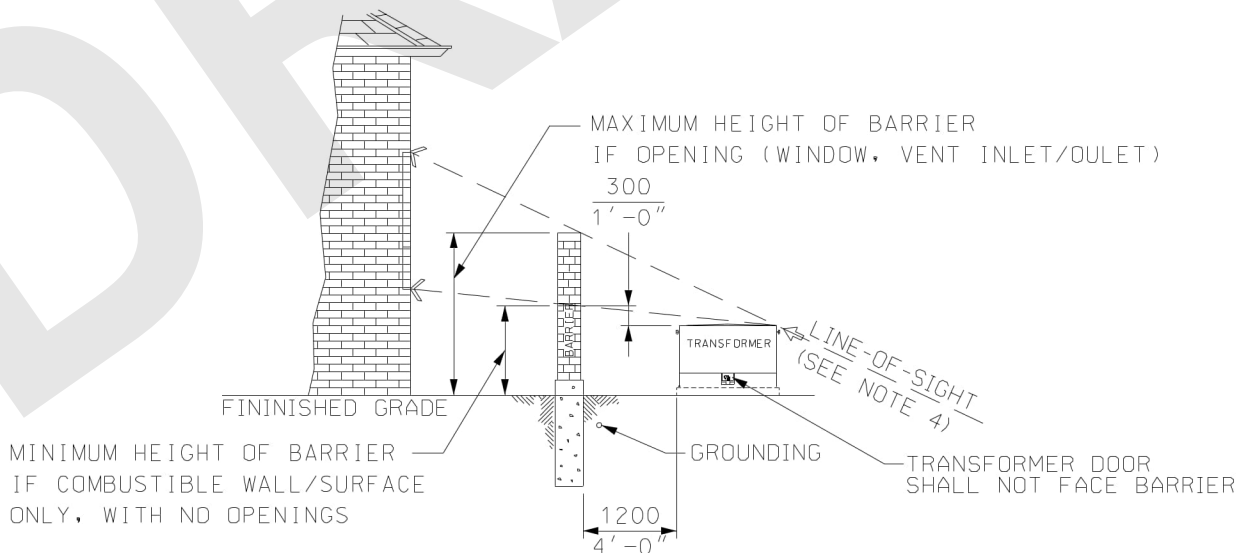

DETAIL 'E' - SECTION VIEW

SINGLE PHASE PADMOUNT TRANSFORMER, LINE OF SIGHT

DISTRIBUTION CONSTRUCTION STANDARD
Civil Construction



Approved By:
B.D. 2022-01-31
Drafted By:
J.D.
Designed By:
B.D.

Original Issue:
G.D./L.G. 2004-11-30

Scale:
N.T.S.

Rev:

5

31-4070

1/2

**PADMOUNT TRANSFORMERS
WITHOUT INTERNAL CURRENT LIMITING FUSE AND
PRESSURE RELIEF DEVICE**



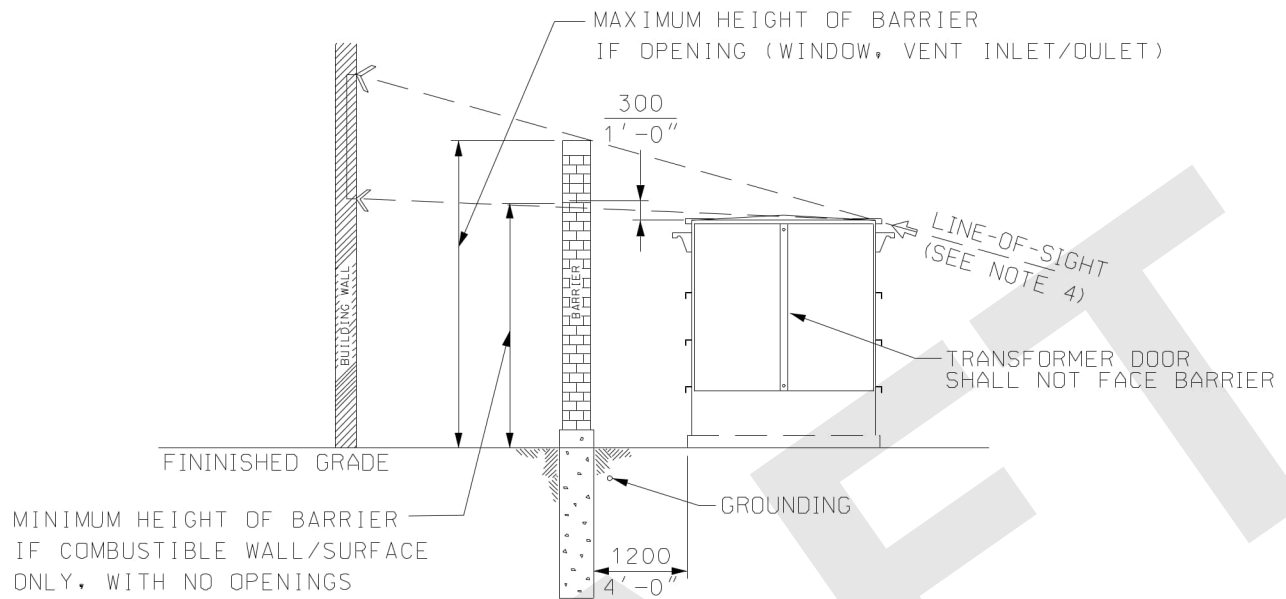

DETAIL 'F' - SECTION VIEW

THREE PHASE PADMOUNT TRANSFORMER, LINE OF SIGHT

NOTES:

- 1) PADMOUNT TRANSFORMERS WITH AN INTERNAL CURRENT LIMITING FUSE AND PRESSURE RELIEF DEVICE SHALL FOLLOW CLEARANCES AS SPECIFIED IN STD 31-4100. THIS SHALL APPLY TO ALL NEW PADMOUNT TRANSFORMERS.
- 2) PADMOUNT TRANSFORMERS WITHOUT AN INTERNAL CURRENT LIMITING FUSE AND PRESSURE RELIEF DEVICE (WHICH INCLUDES ALL LEGACY PADMOUNT TRANSFORMERS) SHALL FOLLOW CLEARANCES AS SPECIFIED IN THIS STANDARD:
 - A) 6000 mm (20'-0") FROM ANY DOOR, WINDOW OR VENTILATION INLET/OUTLET OPENING, OR
 - B) 3000 mm (10'-0") FROM ANY COMBUSTIBLE WALL, SURFACE OR MATERIAL ON A BUILDING, OR
 - C) IF 3A AND 3B CANNOT BE MET, A BARRIER WITH NON-COMBUSTIBLE SURFACE OR MATERIAL IS CONSTRUCTED BETWEEN THE TRANSFORMER AND ANY DOOR, WINDOW, VENTILATION INLET/OUTLET OPENING.
- 3) NON-COMBUSTIBLE BARRIER SURFACE OR MATERIAL SHALL PROVIDE A MINIMUM OF 3 HOUR FIRE RATING.
- 4) NON-COMBUSTIBLE BARRIER SURFACE OR MATERIAL SHALL EXTEND TO A PROJECTION LINE FURTHEST FROM THE CORNER OF THE TRANSFORMER AS PER DETAILS 'E' AND 'F'.
- 5) NON-COMBUSTIBLE BARRIER SHALL BE DESIGNED AND INSTALLED BY CUSTOMER.
- 6) NON-COMBUSTIBLE BARRIER WALL SHALL BE REINFORCED CONCRETE, BRICK OR CONCRETE BLOCK.
- 7) REFERENCE RULE 26-242 ONTARIO ELECTRICAL SAFETY CODE.

DISTRIBUTION CONSTRUCTION STANDARD
Civil Construction

**PADMOUNT TRANSFORMERS
WITHOUT INTERNAL CURRENT LIMITING FUSE AND
PRESSURE RELIEF DEVICE**



Approved By:
B.D. 2022-01-31

Drafted By:
J.D.

Designed By:
B.D.

Original Issue:
G.D./L.G. 2004-11-30

Scale:
N.T.S.

Rev:

5

31-4070

2/2



© CERTIFIED BY TORONTO HYDRO STANDARD <STANDARDS@TORONTOHYDRO.COM>; THIS DOCUMENT IS FOR USE BY TORONTO HYDRO AND AUTHORIZED PERSONS ONLY AS PER THE TERMS IN TORONTO HYDRO STANDARD 00-0002.

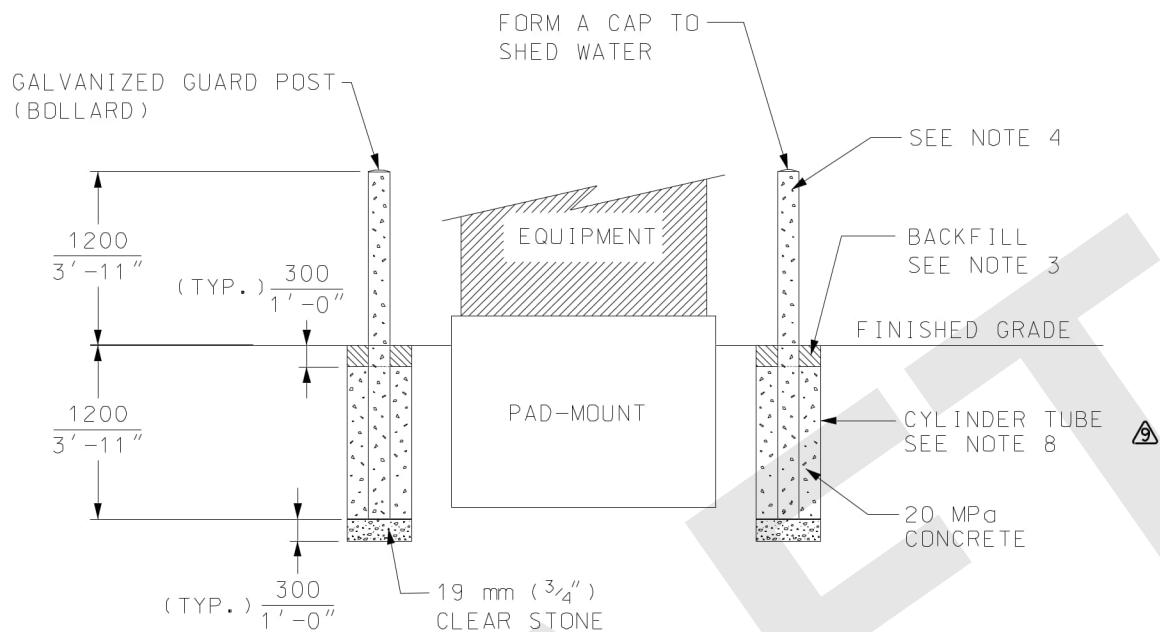

⚠ PAD-MOUNT ELEVATION VIEW

NOTES:

- 1) INSTALL GUARD POSTS (BOLLARDS) IF THE EQUIPMENT IS LESS THAN 1000 mm (3'-4") FROM THE CURB OR ANYWHERE TORONTO HYDRO DEEMS NECESSARY.
- ⚠ 2) NUMBER OF GUARD POSTS AND LOCATIONS SHOWN ARE TYPICAL ARRANGEMENTS. ACTUAL NUMBER OF GUARD POSTS AND LOCATIONS SHALL BE DETERMINED BY TORONTO HYDRO DESIGNER OR INSPECTOR, USING THE FOLLOWING CRITERIA:
 - A) GUARD POST INSTALLATIONS SHALL ALLOW EQUIPMENT DOORS TO BE OPENED THROUGH THEIR FULL RANGE.
 - B) DISTANCE BETWEEN GUARD POSTS AND OUTSIDE EDGE OF THE PAD-MOUNT SHALL BE AS INDICATED IN THIS STANDARD UNLESS OTHERWISE NOTED.
 - C) GUARD POST INSTALLATIONS SHALL ALLOW TORONTO HYDRO PERSONNEL UNIMPEDED ACCESS TO THE EQUIPMENT.
 - D) THE MAX. DISTANCE BETWEEN TWO GUARD POSTS SHALL BE AS INDICATED IN THIS STANDARD.
- 3) BACKFILL REMAINING EXCAVATION AND COMPACT AS PER CIVIL SPECIFICATION CV-CON-01.
- 4) FILL GUARD POSTS WITH 20 MPa CONCRETE.
- 5) PAINT GUARD POST WITH SAFETY YELLOW PAINT. FOR PROPER ADHESION OF PAINT, GUARD POST SHALL BE CLEANED AND PRIMED PRIOR TO PAINTING. A REFLECTIVE STRIP IF REQUIRED SHALL BE PLACED AT EACH POST.
- 6) ALL GUARD POSTS SHALL BE GROUNDED. REFER TO STD. 18-5000 FOR GROUNDING DETAILS. REFER TO STANDARDS 31-4020, 31-4030, 31-4050 FOR PAD-MOUNT CIVIL DETAILS.
- ⚠ 7) CONTRACTOR TO INSTALL A CONSTRUCTION JOINT AROUND THE GUARD POSTS EXCEPT IN GRASSY BOULEVARDS.
- ⚠ 8) CYLINDER TUBE SIZES:
 - 200 mm (8") FOR 100 mm (4") AND 125 mm (5") GUARD POST
 - 250 mm (10") FOR 150 mm (6") GUARD POST
- ⚠ 9) USE 100 mm (4") GUARD POSTS FOR 1-PHASE PADS AND 125 mm (5") OR 150 mm (6") FOR 3-PHASE AND SWITCHGEAR PADS.

DISTRIBUTION CONSTRUCTION STANDARD
Civil Construction

**PAD-MOUNTS
GUARD POSTS (BOLLARDS)**



Approved By:

Drafted By:
J. D.

Designed By:
B. D.

Original Issue:
G. D. / L. G. 2000-12-19

Scale:
N. T. S.

Rev:

9

31-4080

1/3

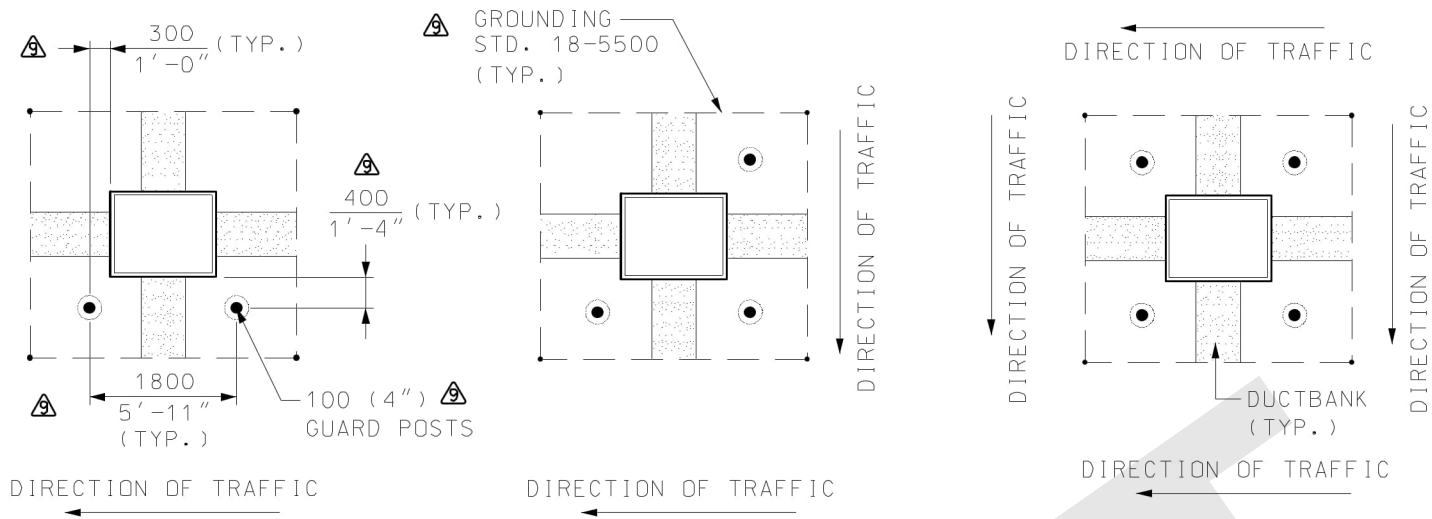

1-PHASE PAD-MOUNT

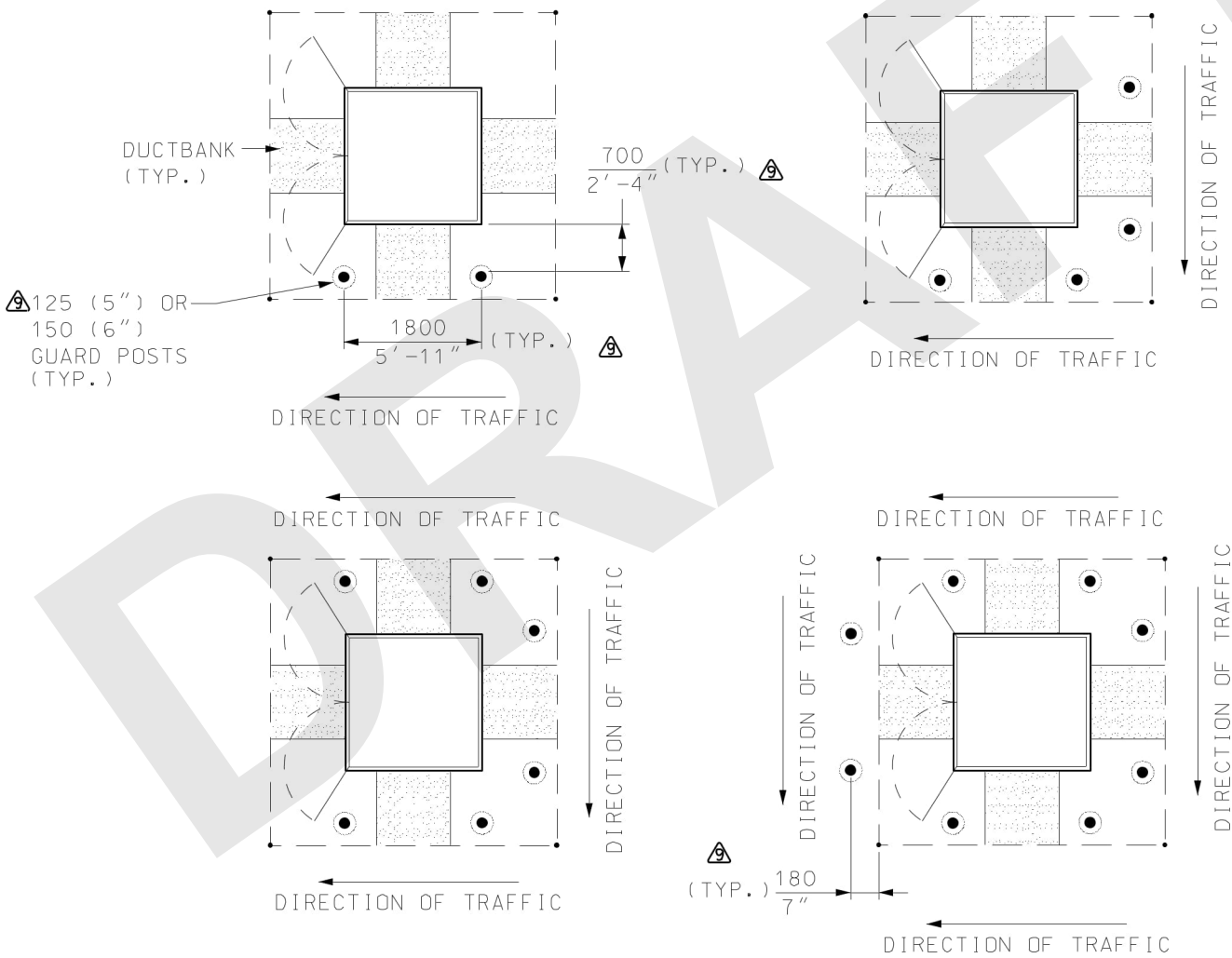

3-PHASE PAD-MOUNT

DISTRIBUTION CONSTRUCTION STANDARD
Civil Construction

**PAD-MOUNTS
GUARD POSTS (BOLLARDS)**



Approved By:

Drafted By:
J. D.

Designed By:
B. D.

Original Issue:
G. D. / L. G. 2000-12-19

Scale:
N. T. S.

Rev:

9

31-4080

2/3

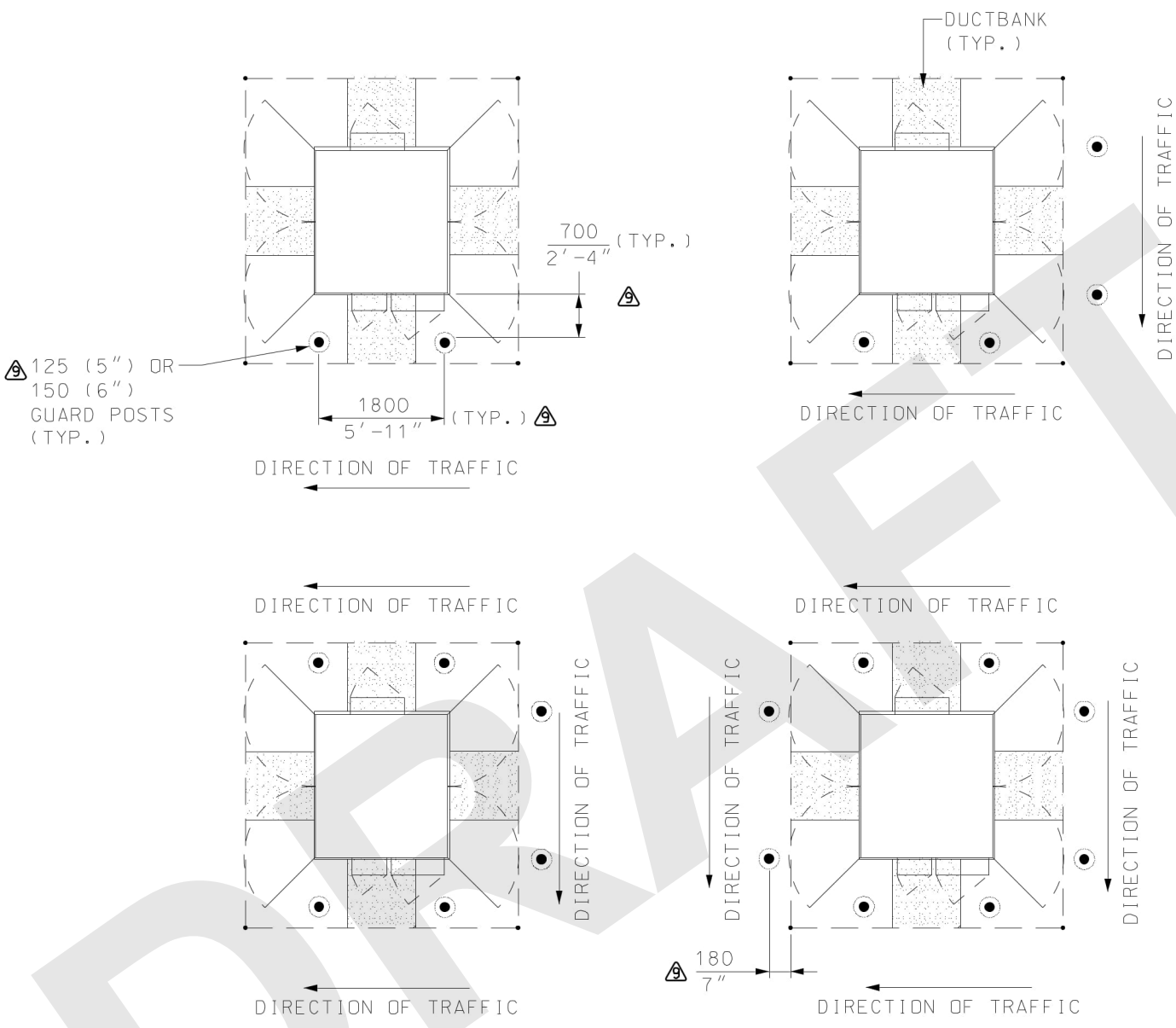

SWITCHGEAR PAD-MOUNT

DISTRIBUTION CONSTRUCTION STANDARD
Civil Construction

**PAD-MOUNTS
GUARD POSTS (BOLLARDS)**

	Approved By:		Original Issue:		Scale:	Rev:	9	31-4080	3/3
	Drafted By:	Designed By:	G. D. / L. G.	2000-12-19	N. T. S.				

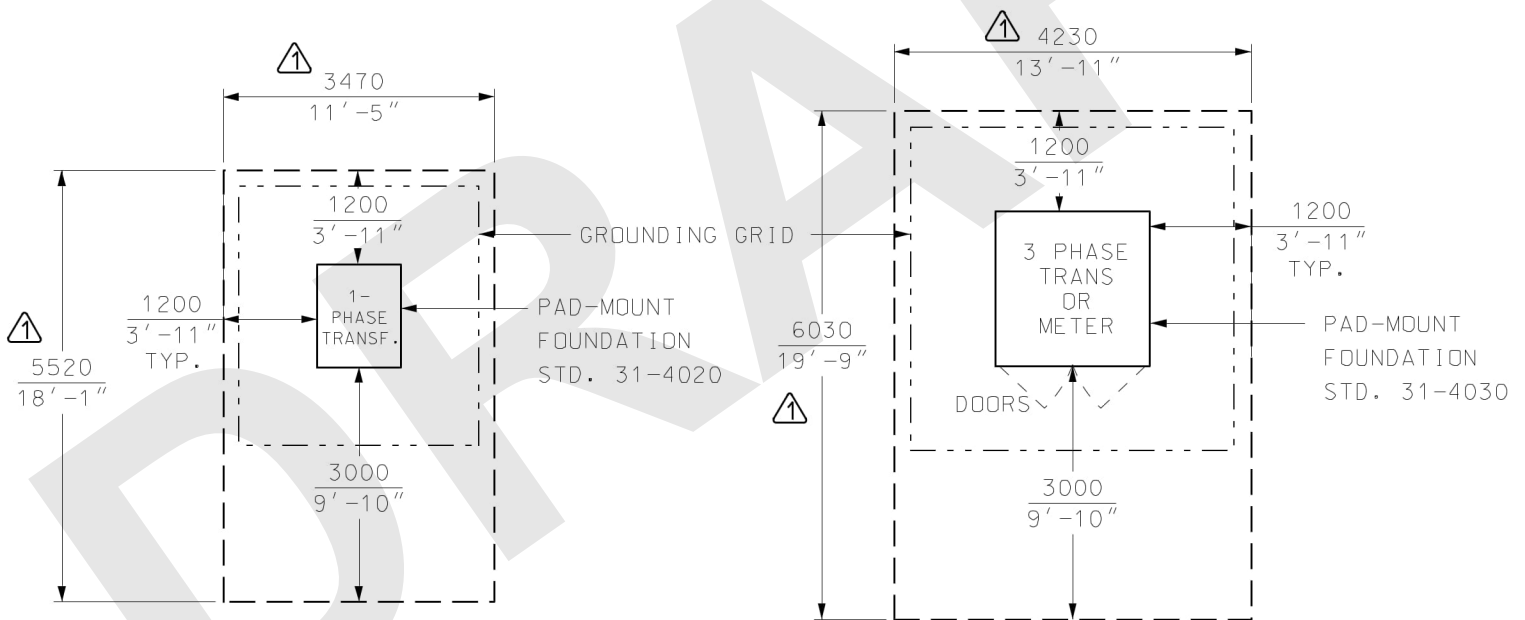
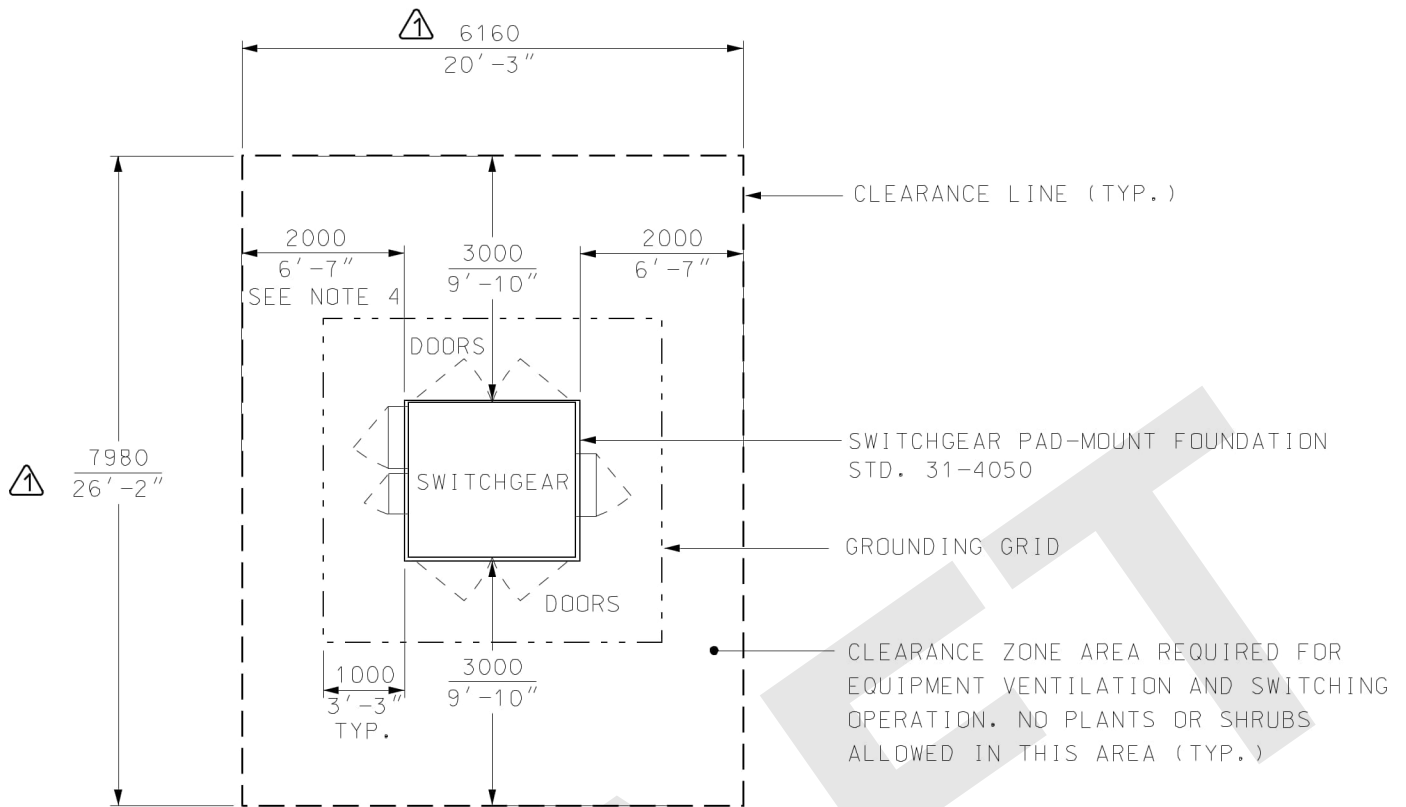

NOTES:

- 1) ANY AND ALL OBJECTS WITHIN THE CLEARANCE ZONE AREA, ARE SUBJECT TO REMOVAL WITHOUT ANY PRIOR NOTICE SHOULD OPERATIONAL OR EMERGENCY CONDITIONS EXIST.
- 2) TORONTO HYDRO SHALL NOT BE HELD RESPONSIBLE FOR ANY COSTS ASSOCIATED WITH THE REMOVAL OR RESULTING DAMAGE TO ANY OBJECTS WITHIN THE CLEARANCE ZONE AREA. THE DEVELOPER/OWNER ASSUMES ALL RESPONSIBILITY FOR ENCRDACHING WITHIN THE CLEARANCE ZONE AREA.
- 3) FINAL FINISHED GRADE WITHIN CLEARANCE ZONE SHALL NOT BE ALTERED.
- 4) IN CASES WHERE THE DESIGN REQUIRES A VALUE LESS THAN THE SPECIFIED LIMITATION, CONTACT STANDARDS AND MATERIALS FOR APPROVAL PRIOR TO IMPLEMENTATION.
- 5) REFER TO STANDARD 31-4080 GUARD POSTS (BOLLARDS) PLACEMENT FOR DETAILS.
- 6) REFER TO STANDARD 18-5500 FOR PAD-MOUNTED EQUIPMENT GROUNDING DETAILS.

DISTRIBUTION CONSTRUCTION STANDARD
Civil Construction

**PAD-MOUNTS
CLEARANCE ZONE**



Approved By:

Drafted By:
J. D.

Designed By:
B. D.

Original Issue:
B. D. 2019-08-26

Scale:
N. T. S.

Rev:
1

31-4100

1/1

© CERTIFIED BY TORONTO HYDRO STANDARD <STANDARDS@TORONTOHYDRO.COM>, THIS DOCUMENT IS FOR USE BY TORONTO HYDRO AND AUTHORIZED PERSONS ONLY AS PER THE TERMS IN TORONTO HYDRO STANDARD 00-0002.

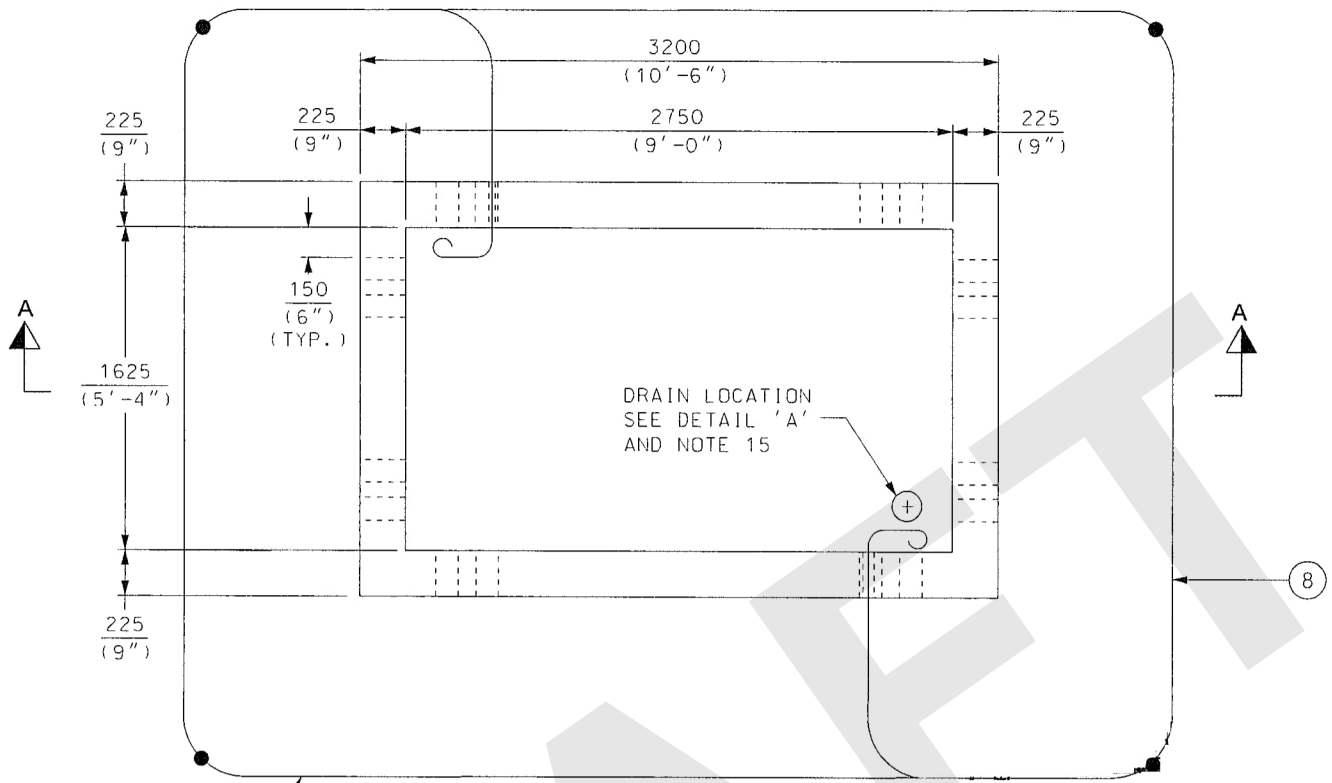

GROUNDING ALSO APPLIES TO PRECAST OPTION. REFER TO STD. 18-5200

CAST-IN PLACE OPTION **PLAN VIEW**

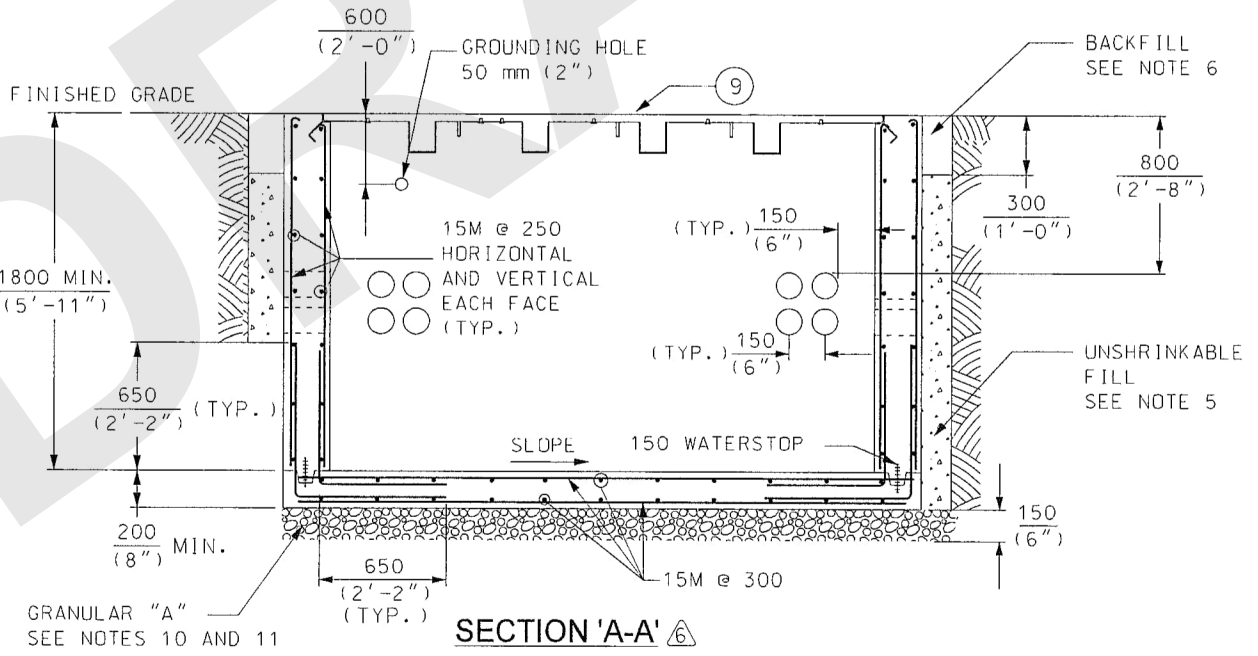

SECTION 'A-A'

DISTRIBUTION CONSTRUCTION STANDARD Civil Construction		SPLICE VAULT 'A' FOR 1000 kcmil CABLES 1625 mm (5'-4") X 2750 mm (9'-0")				
	Approved By: <i>[Signature]</i> 2017/02/10				Scale:	Rev: 6
	Drafted By: B. D.	Designed By: J. D.	Original Issue: G. D. / C. P.	2003-05-30	N. T. S.	31-5120
						1/5

© CERTIFIED BY TORONTO HYDRO STANDARD <STANDARDS@TORONTOHYDRO.COM>, THIS DOCUMENT IS FOR USE BY TORONTO HYDRO AND AUTHORIZED PERSONS ONLY AS PER THE TERMS IN TORONTO HYDRO STANDARD 00-0002.

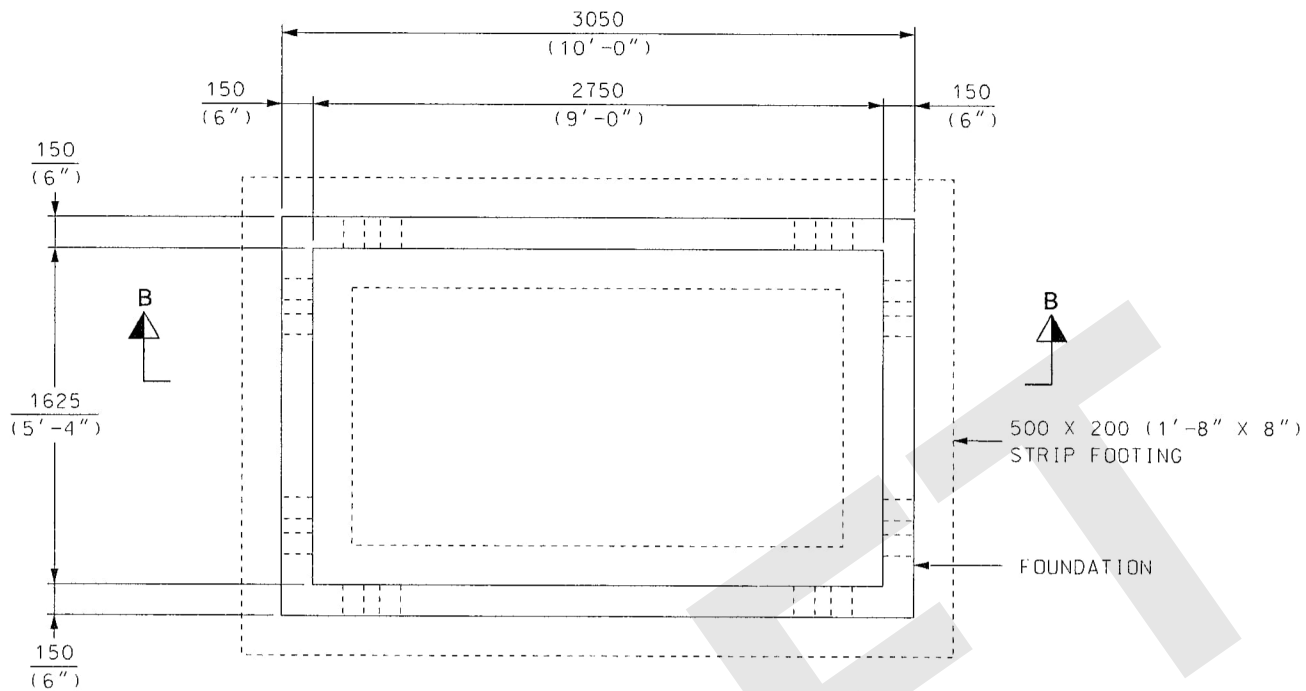

PRECAST OPTION ⚠
PLAN VIEW

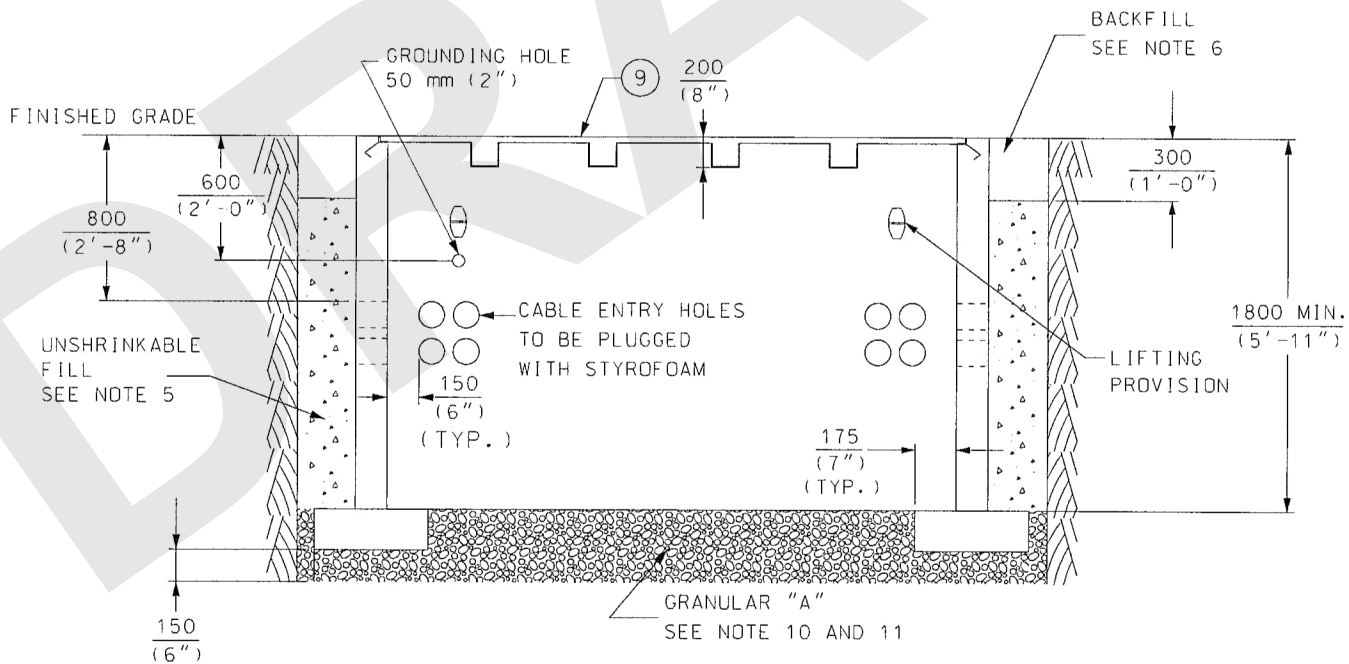

SECTION 'B-B' ⚠

DISTRIBUTION CONSTRUCTION STANDARD
 Civil Construction

SPLICE VAULT 'A'
 FOR 1000 kcmil CABLES
 1625 mm (5'-4") X 2750 mm (9'-0")



Approved By:
J. D. 2017/02/10

Drafted By:
 B. D.

Designed By:
 J. D.

Original Issue:
 G. D. / C. P. 2003-05-30

Scale:
 N. T. S.

Rev:
6

31-5120

2/5

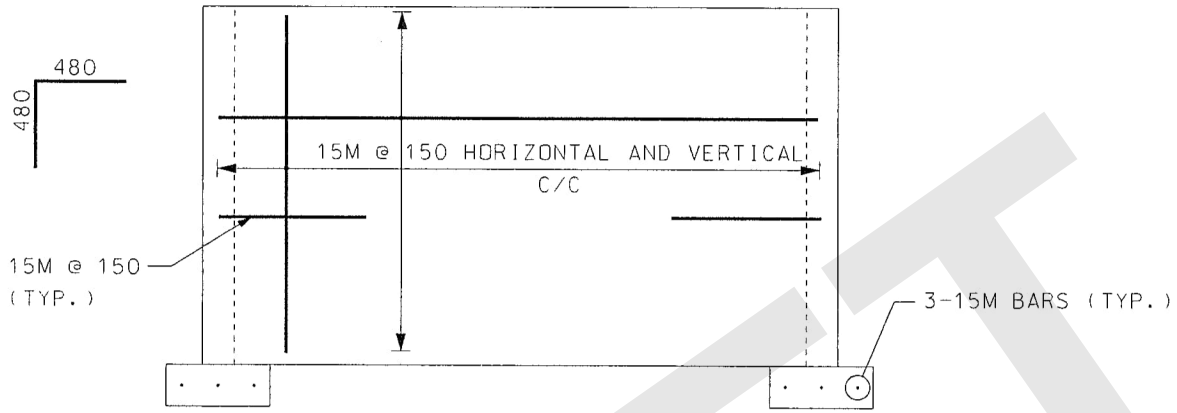

PRECAST OPTION STRUCTURE REINFORCING DETAIL ⚠

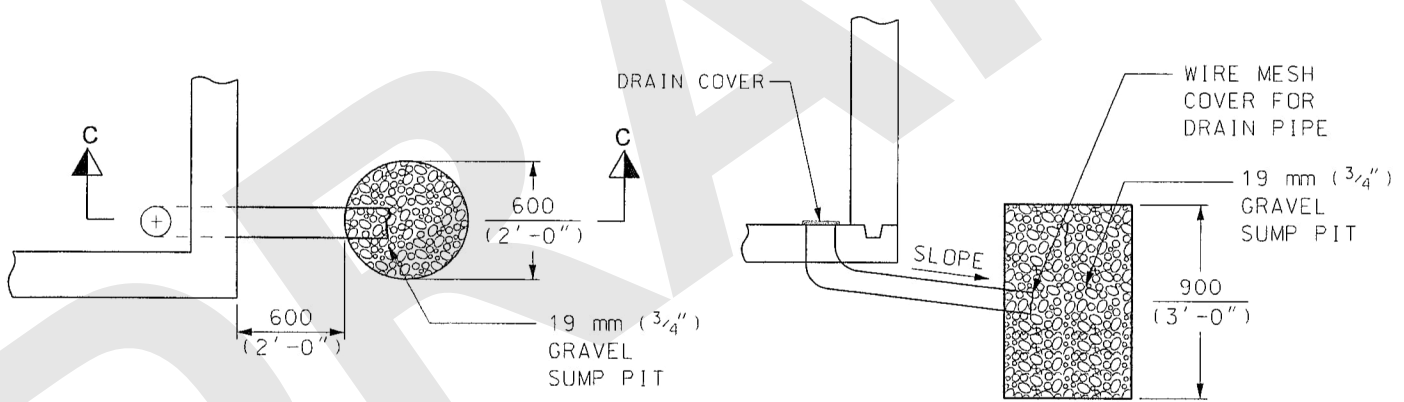

DETAIL 'A' ⚠

ALTERNATIVE DRAIN PIT FOR
CAST-IN PLACE OPTION

SECTION 'C-C' ⚠

DISTRIBUTION CONSTRUCTION STANDARD
Civil Construction

SPLICE VAULT 'A'
FOR 1000 kcmil CABLES
1625 mm (5'-4") X 2750 mm (9'-0")



Approved By:
Deined 2017/02/10

Drafted By:
B. D.

Designed By:
J. D.

Original Issue:
G. D. / C. P. 2003-05-30

Scale:
N. T. S.

Rev: **6**

31-5120

3/5

675 mm (2'-3")
BENDING RADIUS
FOR 1000 kcmil
CABLE

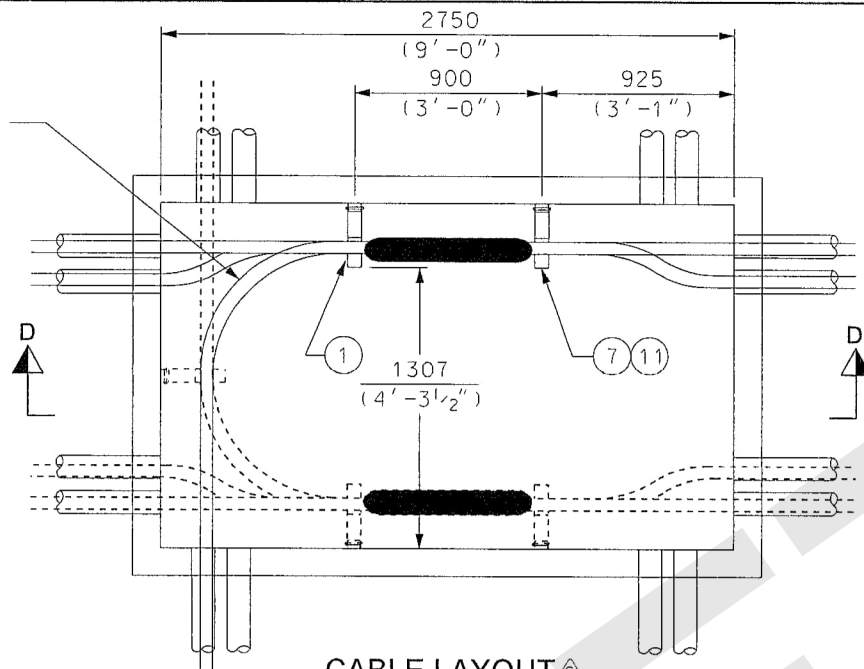

CABLE LAYOUT Ⓐ

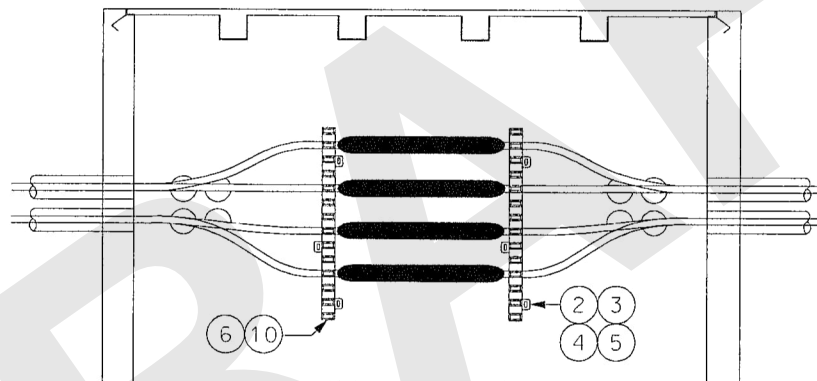

SECTION 'D-D' Ⓐ

BILL OF MATERIALS FOR 31-5120

ITEM NO.	DESCRIPTION	ITEM I.D.	QTY
1	TIE CABLE TY-RAP 14.6" LENGTH	2320047	6
2	ANCHOR DROP-IN FOR 1/2" BOLTS 2" LONG	2500018	6
3	BOLT MACHINE HEX 1/2" X 2" STAINLESS STEEL	2550245	6
4	WASHER ROUND FOR 1/2" STAINLESS STEEL BOLT	2530036	6
5	WASHER LOCK 1/2" STAINLESS STEEL	2530128	6
6	CABLE RACK TYPE C	7360300	4 Ⓐ
7	CABLE ARM 2 WAY TYPE C	7340303	16 Ⓐ
ASSOCIATED STANDARDS			
8	GROUNDING REQUIREMENTS	STD. 18-5200	1
9	SPLICE VAULT COVER	STD. 31-8310	1
10	CABLE RACK	STD. 31-8260	1
11	CABLE ARMS	STD. 31-8270	1
12	SUPPORT OF CABLES ON CABLE ARMS	STD. 16-4540	1
13	TYPICAL DRAIN CONNECTION TO SEWER	STD. 31-7100	1

DISTRIBUTION CONSTRUCTION STANDARD
Civil Construction

SPLICE VAULT 'A'
FOR 1000 kcmil CABLES
1625 mm (5'-4") X 2750 mm (9'-0")



Approved By: *[Signature]* 2017/02/10
Drafted By: B.D.
Designed By: J.D.

Original Issue: G.D./C.P. 2003-05-30

Scale: N.T.S.

Rev: 6

31-5120

4/5

NOTES:

GENERAL NOTES:

- 1) DESIGN IN ACCORDANCE WITH CANADIAN HIGHWAY BRIDGE DESIGN CODE CAN/CSA-S6-06, CL-625-DNT LIVE LOADING.
- 2) CONCRETE SHALL HAVE A MINIMUM 28-DAY COMPRESSIVE STRENGTH OF 35 MPa. CONCRETE PRODUCTION AND PLACEMENT SHALL CONFORM TO LATEST CSA-A23.1, ALL TESTING SHALL CONFORM TO LATEST CSA-A23.2. EXPOSURE CLASSIFICATION TO BE C-1 DUE TO EXPOSURE TO CHLORIDES WITH OR WITHOUT FREEZING AND THAWING CONDITIONS. ALL REINFORCING TO CONFORM TO LATEST CSA STANDARD G30.18, Fy = 400 MPa.
- 3) CONCRETE COVER SHALL BE:
 - A) BARS AT INSIDE FACES.....40 mm (1½")
 - B) BARS AT OUTSIDE FACES.....50 mm (2")
 - C) CONCRETE PLACED AGAINST THE EARTH.....75 mm (3")
- 4) ALL EXPOSED EDGES SHALL HAVE 25 mm CHAMFER.
- 5) EXCAVATION SHALL BE BACKFILLED WITH UNSHRINKABLE FILL TO WITHIN 300 mm (1'-0") FROM FINISHED GRADE.
- 6) BACKFILL THE REMAINING 300 mm (1'-0") TO FINISHED GRADE AS PER SPEC. #CV-CON-01 CLAUSE 5.1.17.
- 7) TORONTO HYDRO INSPECTOR SHALL BE PRESENT DURING THE INSTALLATION, 24-HOUR NOTICE IS REQUIRED PRIOR TO STARTING THE INSTALLATION.
- 8) FOR VEHICULAR TRAFFIC REFER TO GUARD POSTS (BOLLARDS) STD. 31-4080. LOCATION SHALL BE KEPT CLEAR OF OBSTRUCTIONS FOR ACCESS BY TORONTO HYDRO PERSONNEL AND EQUIPMENT.
- 9) SPLICE VAULT 'A' CAN BE USED TO ACCOMMODATE THE INSTALLATION OF 1000 kcmil CABLES WITH THE FOLLOWING CONDITIONS:
 - EDGE OF DUCTS ENTER AND EXIT THE VAULT 150 mm (6") FROM THE ADJACENT WALL TO ELIMINATE THE INTRODUCTION OF BENDS IN THE CABLES,
 - NO LOOPING OF CABLES INSIDE THE VAULT,
 - SPLICES ARE DONE ALONG THE LONGER WALLS,
 - MAXIMUM OF TWO CIRCUITS.
- 10) ANY SOFT SPOTS ENCOUNTERED UNDER VAULT SHALL BE REMOVED AND FILLED WITH MASS CONCRETE OF 15 MPa MINIMUM STRENGTH TO UNDERSIDE OF FLOOR SLAB. IF NOT ENCOUNTERED, PLACE 150 mm (6") GRANULAR "A" BEDDING AND COMPACT TO 95% STANDARD PROCTOR DENSITY.
- 11) DO NOT PLACE FLOOR SLAB IN FROZEN GROUND.
- 12) STRUCTURAL STEEL SHALL CONFORM TO CSA STANDARD G40.21 LATEST EDITION GRADE 300W.
- 13) ALL EXPOSED STRUCTURAL STEEL SHALL BE HOT DIP GALVANIZED AS PER CSA SEC. G164 LATEST EDITION.
- 14) UNUSED CABLE ENTRY DUCTS SHALL BE PLUGGED WITH DUCT PLUGS AND PARGED PRIOR TO BACKFILLING.

CAST-IN-PLACE OPTION:

- 15) VAULT SHALL BE DRAINED AS FOLLOWS:
 - OPTION 1 - DRAIN INTO CITY'S SEWERS AS PER STD. 31-7100.
 - OPTION 2 - DRAIN INTO A TO GRAVEL SUMP PIT AS SHOWN IN THIS STANDARD.
- 16) LOCATION OF DRAIN PIPE SHALL BE DETERMINED AS PER PROJECT'S SITE CONDITIONS.

PRECAST OPTION:

- 17) MANUFACTURER SHALL ADD DATE OF MANUFACTURE STAMP ON ALL PRECAST UNITS.
- 18) PROVIDE 90° STANDARD HOOK FOR WALL HORIZONTAL REINFORCING BARS.
- 19) LIFTING HOLES CAN BE INSTALLED IN FOUNDATION WALLS FOR MANUFACTURER'S LIFTING PREFERENCE.
- 20) 4-LIFTING ANCHORS FOR LIFTING PURPOSES BY OTHERS SHALL BE PROVIDED ON THE INSIDE OF ALL FOUNDATION WALLS AND ON TOP OF STRIP FOOTING AS SHOWN IN THIS STANDARD. LIFTING ANCHORS SHALL BE GALVANIZED. LIFTING ANCHORS SHALL BE CAPABLE OF LIFTING THE PRECAST UNITS.
- 21) CONTRACTOR TO PLUG ALL HOLES (LIFTING AND GROUNDING) AND PARGED PRIOR TO BACKFILLING.
- 22) PRECAST UNITS ARE DELIVERED BY CRANE-EQUIPPED TRUCKS. EXCAVATION MUST BE READY, SAFE AND ACCESSIBLE FOR UNLOADING FROM THE REAR OF THE TRUCK. MINIMUM OVERHEAD CLEARANCE OF 5500 mm (18'-0") IS REQUIRED. CONTRACTOR SHALL ASSIST SUPPLIER IN LOWERING THE PRECAST UNITS INTO EXCAVATION.

DISTRIBUTION CONSTRUCTION STANDARD Civil Construction		SPLICE VAULT 'A' FOR 1000 kcmil CABLES 1625 mm (5'-4") X 2750 mm (9'-0")					
	Approved By: <i>[Signature]</i> 2017/02/10		Original Issue:		Scale:	Rev:	
	Drafted By: B.D.	Designed By: J.D.	G.D./C.P. 2003-05-30		N.T.S.	6	31-5120 5/5

© CERTIFIED BY TORONTO HYDRO STANDARD <STANDARDS@TORONTOHYDRO.COM>; THIS DOCUMENT IS FOR USE BY TORONTO HYDRO AND AUTHORIZED PERSONS ONLY AS PER THE TERMS IN TORONTO HYDRO STANDARD 00-0002.

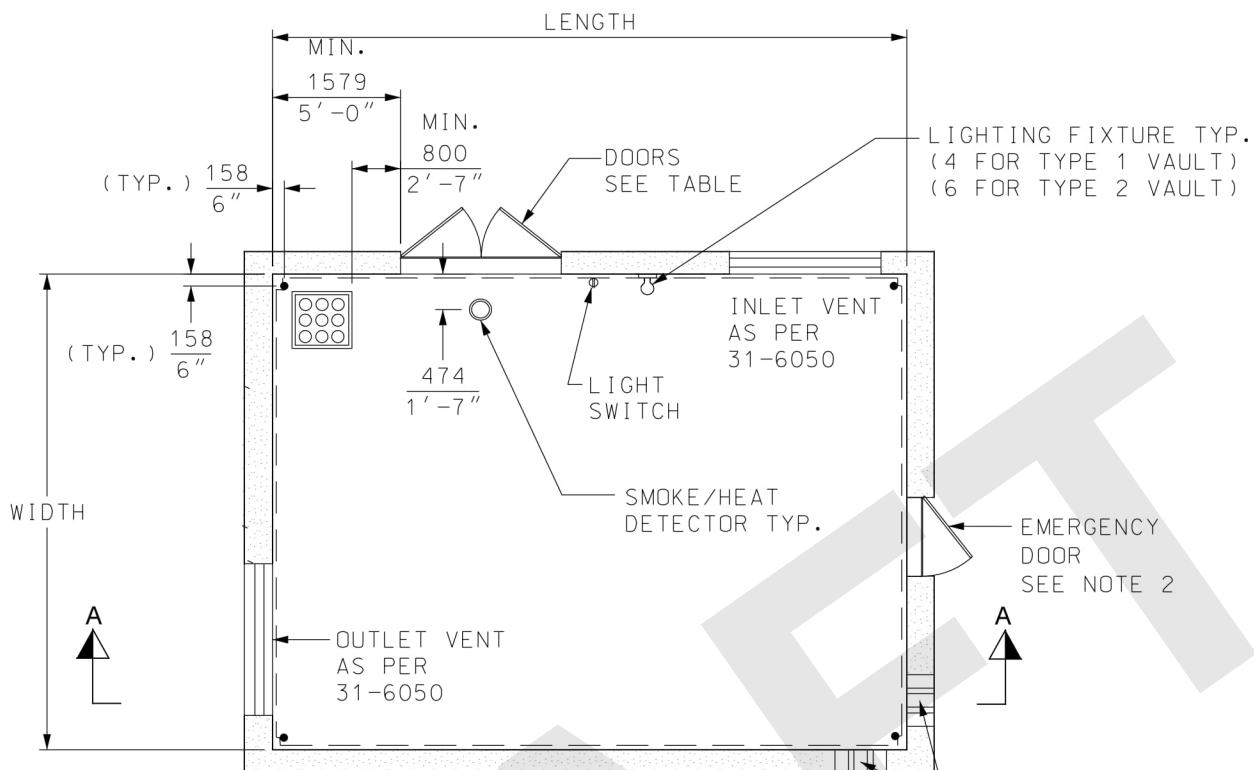

PLAN VIEW

GENERAL VAULT LAYOUT

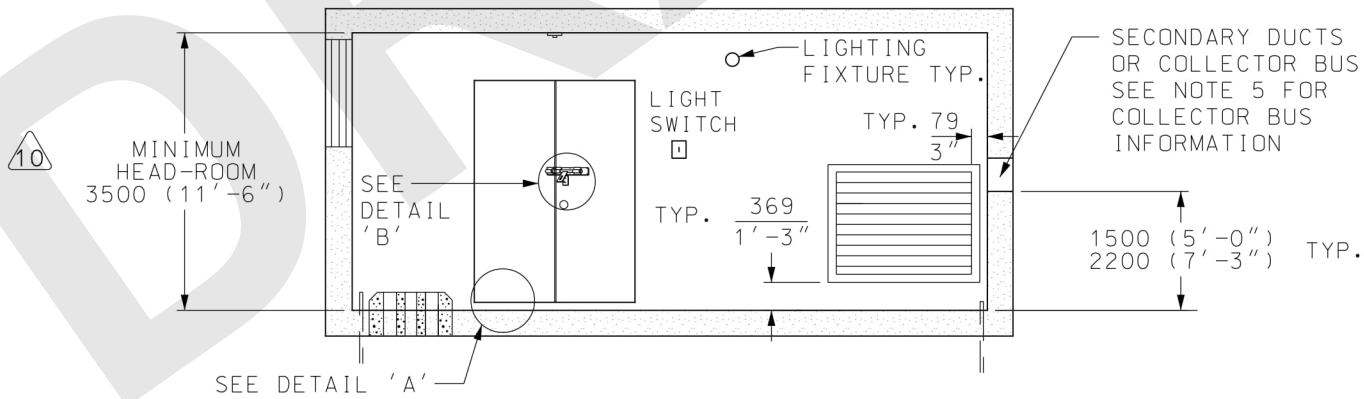

SECTION 'A-A'

DISTRIBUTION CONSTRUCTION STANDARD
Civil Construction

CUSTOMER-OWNED STRUCTURES
ABOVE GRADE - WALK-IN VAULT



Approved By:

Drafted By:
J. D.

Designed By:
B. D.

Original Issue:
C. P. 2003-11-27

Scale:
N. T. S.

Rev: 10

31-6020

1/4

© CERTIFIED BY TORONTO HYDRO STANDARD <STANDARDS@TORONTOHYDRO.COM>, THIS DOCUMENT IS FOR USE BY TORONTO HYDRO AND AUTHORIZED PERSONS ONLY AS PER THE TERMS IN TORONTO HYDRO STANDARD 00-0002.

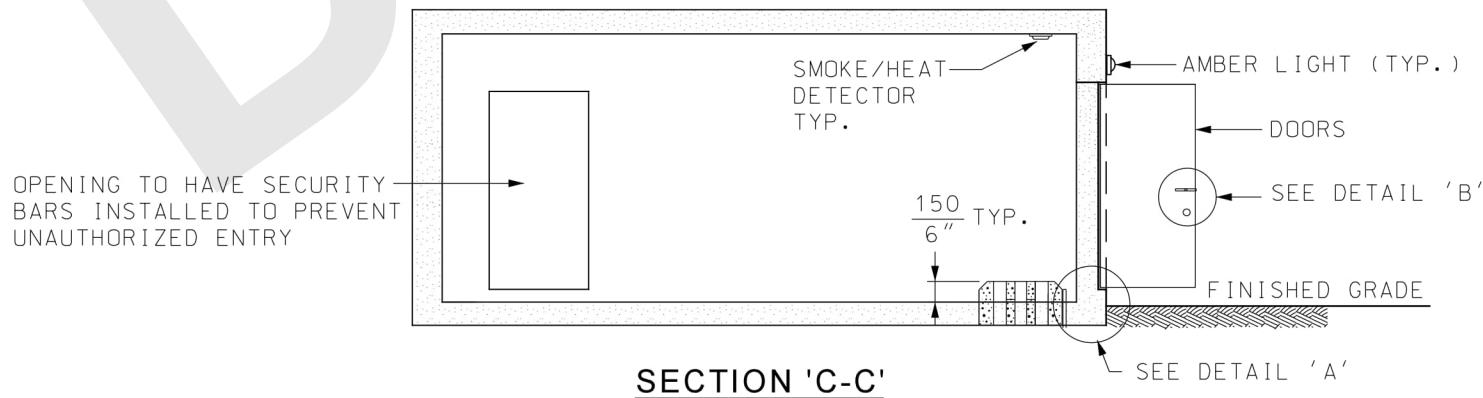
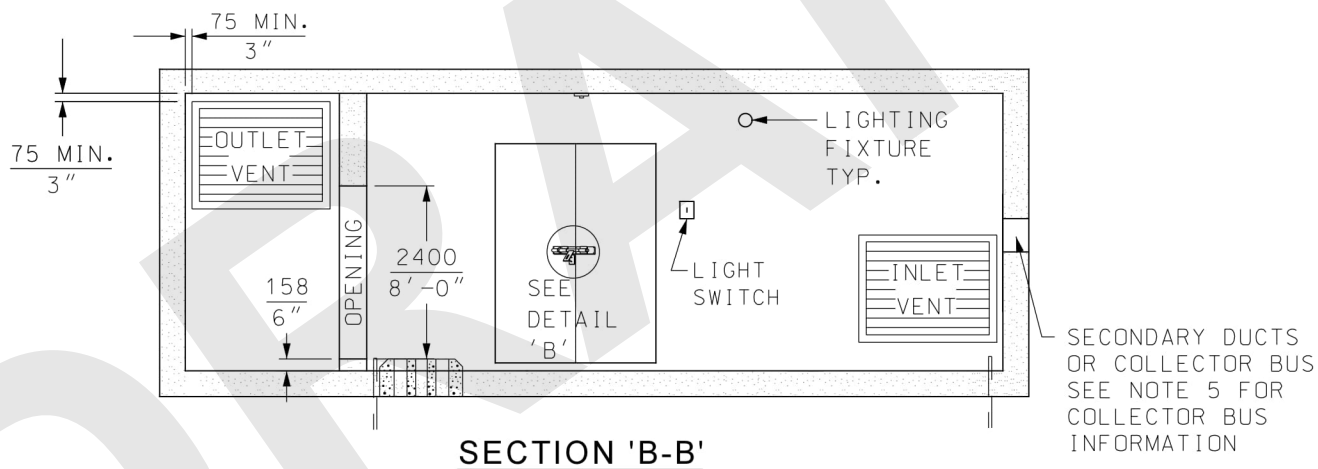
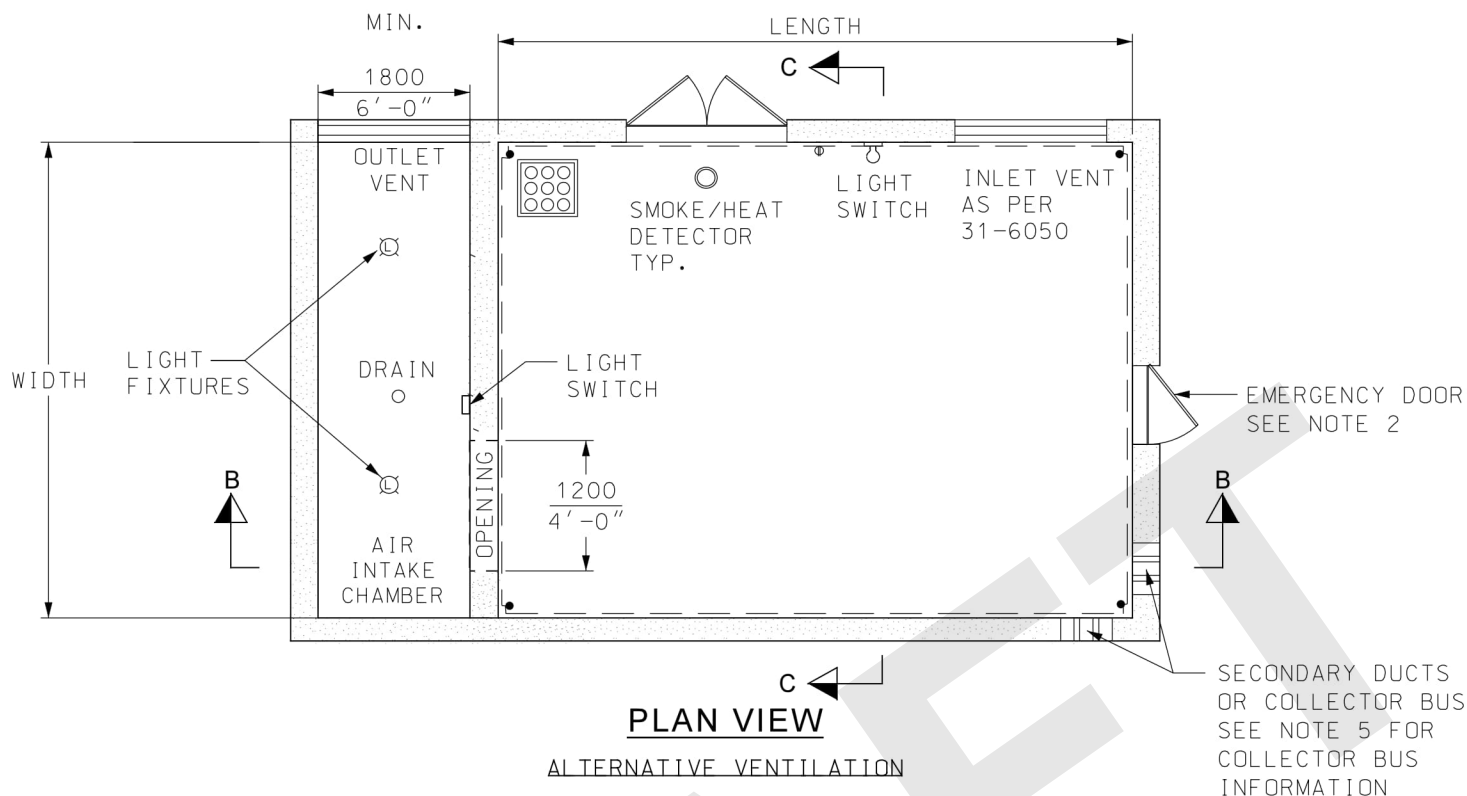

DISTRIBUTION CONSTRUCTION STANDARD
Civil Construction

CUSTOMER-OWNED STRUCTURES
ABOVE GRADE - WALK-IN VAULT



Approved By:

Drafted By:
J. D.

Designed By:
B. D.

Original Issue:
C. P. 2003-11-27

Scale:
N. T. S.

Rev: 10

31-6020

2/4

© CERTIFIED BY TORONTO HYDRO STANDARD <STANDARDS@TORONTOHYDRO.COM>; THIS DOCUMENT IS FOR USE BY TORONTO HYDRO AND AUTHORIZED PERSONS ONLY AS PER THE TERMS IN TORONTO HYDRO STANDARD 00-0002.

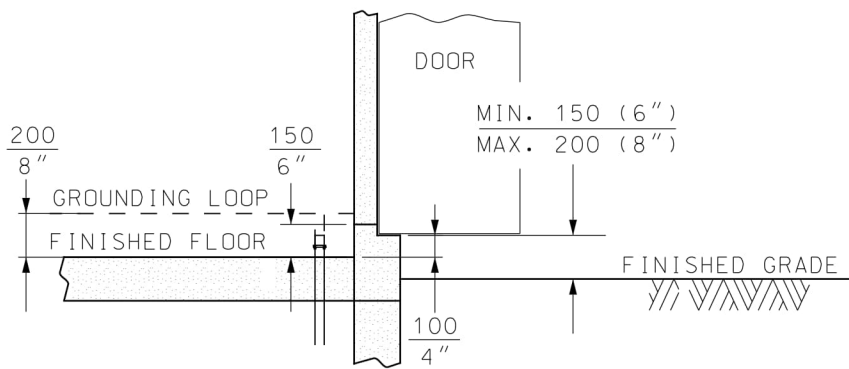

10 **DETAIL 'A'**
DOOR AND GROUNDING DETAIL

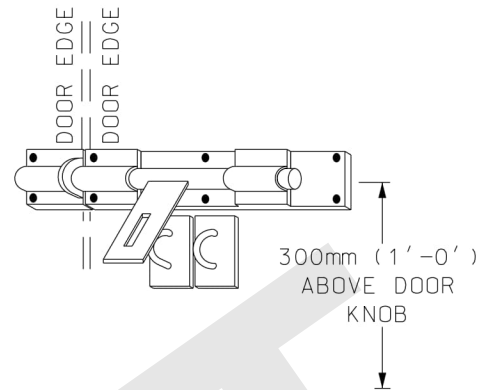

DETAIL 'B'
DOOR PAD BOLT
250 mm (10") BOLT

ABOVE GRADE - WALK-IN VAULT SIZES					
TYPE	TX. RATING	LENGTH	WIDTH	DOORS	ELECTRICAL EQUIPMENT
1	UP TO 2000 kVA	8000 (26'-3")	6000 (19'-8")	1200x2400 HIGH (4'x8')	10 REFER TO SECTION 13 STANDARDS FOR DETAILS
2	2500 - 4000 kVA	10000 (32'-0")	8000 (26'-3")	1200x3000 HIGH (4'x10')	

ABOVE GRADE - WALK-IN VAULT MIN. LOADING (SUSPENDED SLAB)					
TYPE	TX. RATING	ROOM AREA	10 * DEAD LOAD (APPROXIMATE)	10 LIVE LOAD	
1	UP TO 2000 kVA	48 m ²	10 17,110 kg	REFER TO ONATRIO BUILDING CODE FOR DETAILS	
2	2500 - 4000 kVA	80 m ²	10 30,200 kg		

10 * DEAD LOAD = TOTAL AGGREGATE WEIGHT OF ELECTRICAL EQUIPMENT X 1.2 SAFETY FACTOR (ELECTRICAL EQUIPMENT = TRANSFORMERS WITH OR WITHOUT PROTECTORS)

DISTRIBUTION CONSTRUCTION STANDARD
Civil Construction

CUSTOMER-OWNED STRUCTURES
ABOVE GRADE - WALK-IN VAULT



Approved By:

Drafted By:
J. D.

Designed By:
B. D.

Original Issue:
C. P. 2003-11-27

Scale:
N. T. S.

Rev: **10**

31-6020

3/4

NOTES:

10

- 1) THIS DRAWING SHALL BE READ IN CONJUNCTION WITH THE LATEST REVISION OF TORONTO HYDRO REQUIREMENTS FOR THE DESIGN AND CONSTRUCTION OF CUSTOMER-OWNED STRUCTURES DOCUMENT CONDITION OF SERVICE REF. 5.
- 2) EMERGENCY DOOR IS REQUIRED IN NEW TRANSFORMER VAULTS, LOCATION OF WHICH SHALL BE APPROVED BY TORONTO HYDRO REPRESENTATIVE. EMERGENCY DOOR SHALL HAVE PANIC HARDWARE INSTALLED TO ALLOW DOOR TO OPEN FROM THE INSIDE. THERE SHALL BE NO METHOD OF OPENING AN EMERGENCY DOOR FROM THE OUTSIDE.
- 3) LOCATION OF ELECTRICAL LIGHT FIXTURE CAN BE INSTALLED AS SHOWN OR AN ALTERNATE LOCATION CAN BE CHOSEN PROVIDED ADEQUATE SPACE AND CLEARANCE IS PROVIDED TO ALLOW FOR PROPER OPERATION AND MAINTENANCE OF ELECTRICAL EQUIPMENT.
- 4) DOORS, LOUVER, SECURITY BARS AND ANY METAL PRODUCT SHALL BE GROUNDED BY CONNECTING 2/0 FLEX STRANDED COPPER TO THE GROUNDING LOOP. CONNECTION SHALL BE BY USING PARALLEL GROOVE CLAMPS AND GROUNDING LUG.
- 5) FOR ADJACENT ELECTRICAL ROOMS, COLLECTOR BUSES OR BUS STUBS CAN BE INSTALLED INSTEAD OF DUCTS AT A MINIMUM HEIGHT OF 2134 mm (7'-0") ABOVE FINISHED FLOOR WITH 600 mm (1'-11⁵/₈") CLEARANCE ON EITHER SIDE TO ALLOW PROPER TERMINATION OF CABLES. COLLECTOR BUS TO BE INSTALLED AS PER SECTION 13 AND ALLOW PROPER UNHINDERED OPERATION AND ACCESS OF EQUIPMENT. SEE STD. 15-1500 FOR COLLECTOR BUS DETAILS.
- 6) FOR SUSPENDED SLAB DESIGN, DEFINED LOAD CAPACITY IS TO BE A MINIMUM. THE VAULT DESIGN MUST COMPLY WITH THE MOST RECENT VERSION OF THE ONTARIO BUILDING CODE (OBC) AND BE SEALED BY A PROFESSIONAL ENGINEER OF ONTARIO. INCREASED CAPACITY MAY BE REQUIRED DEPENDING ON EXTERNAL FACTORS OR JOINT USE EQUIPMENT ROOMS.
- 7) ALL LISTED KVA RATINGS ARE AGGREGATED.
- 8) SAFETY FACTOR (S.F.) OF 1.2 SHALL BE ASSUMED IN THE DEAD LOAD CALCULATIONS
- 9) FOR SCENARIOS WITH TRANSFORMER CAPACITY GREATER THAN 4 MVA, CUSTOMER TO ATTAIN EQUIPMENT SHOP DRAWINGS AND DETERMINE THE REQUIRED LOADING OUTSIDE OF THE LISTED REQUIREMENTS.
- 10) GROUND RODS SHALL BE A MINIMUM 3000 mm (10'-0") APART.

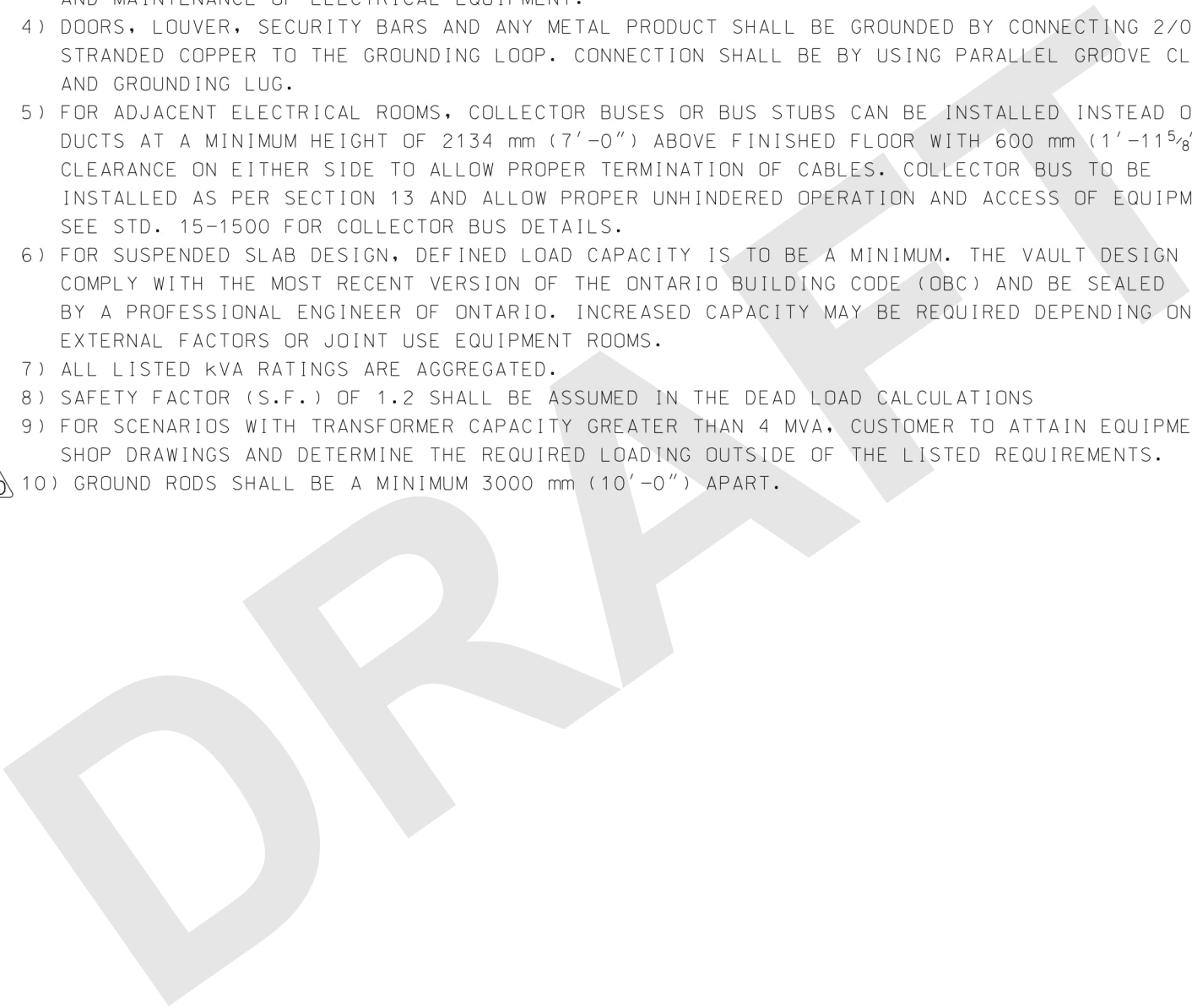

DISTRIBUTION CONSTRUCTION STANDARD
Civil Construction

**CUSTOMER-OWNED STRUCTURES
ABOVE GRADE - WALK-IN VAULT**



Approved By:

Drafted By:
J. D.

Designed By:
B. D.

Original Issue:
C. P. 2003-11-27

Scale:
N. T. S.

Rev: 10

31-6020

4/4

© CERTIFIED BY TORONTO HYDRO STANDARD <STANDARDS@TORONTOHYDRO.COM>, THIS DOCUMENT IS FOR USE BY TORONTO HYDRO AND AUTHORIZED PERSONS ONLY AS PER THE TERMS IN TORONTO HYDRO STANDARD 00-0002.

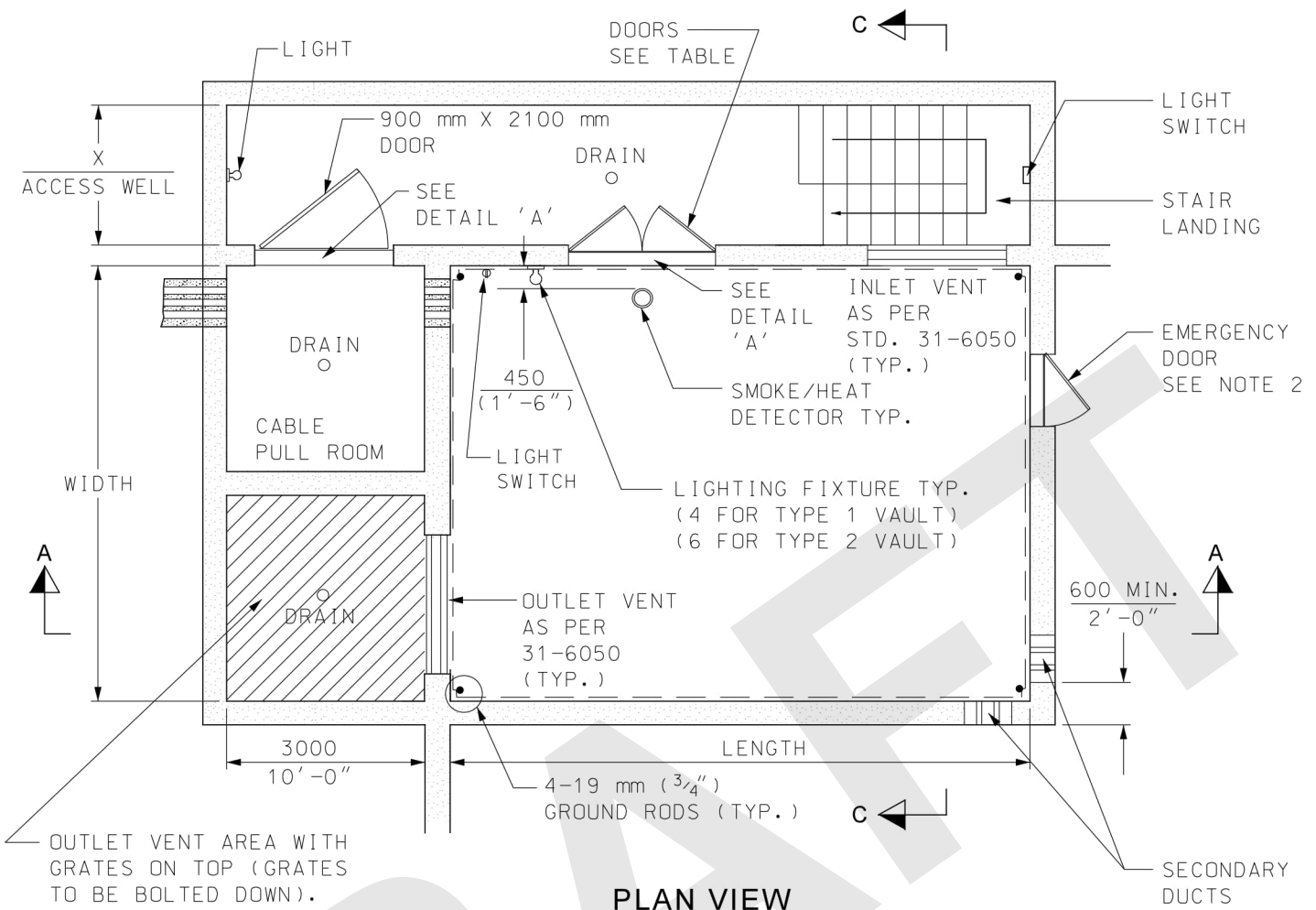

PLAN VIEW
NATURAL CROSS-VENTILATION

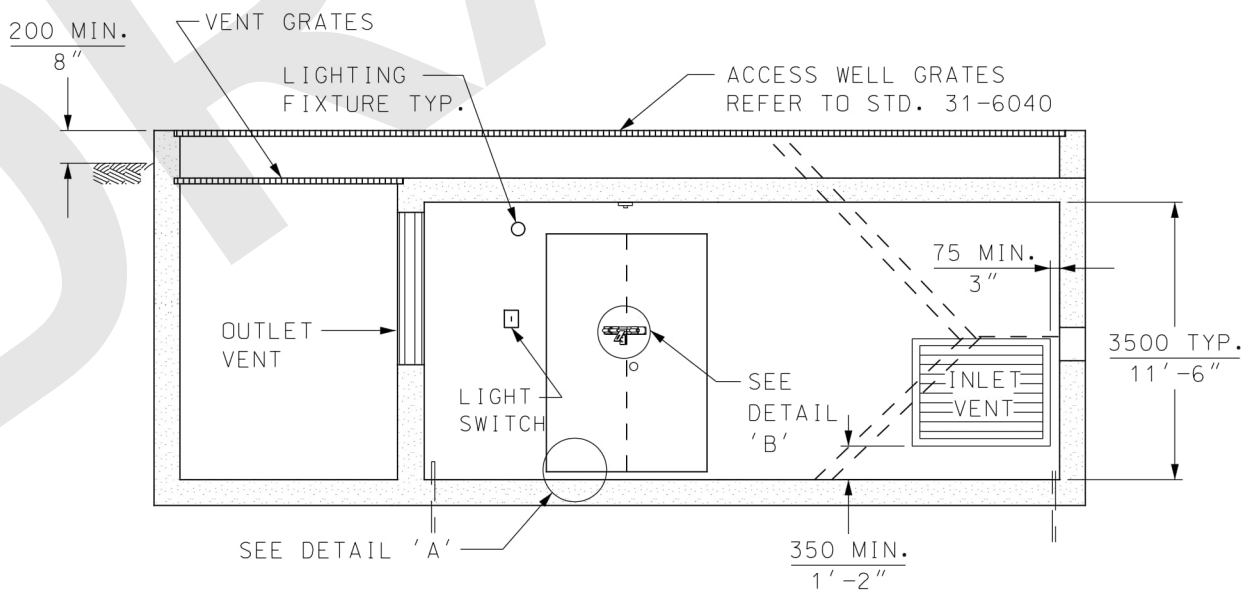

SECTION 'A-A'

DISTRIBUTION CONSTRUCTION STANDARD
Civil Construction

CUSTOMER-OWNED STRUCTURES
BELOW-GRADE WALK-IN VAULT



Approved By:

Drafted By:
B. D.

Designed By:
B. D.

Original Issue:
C. P. 2003-11-27

Scale:
N. T. S.

Rev: 12

31-6030

1/4

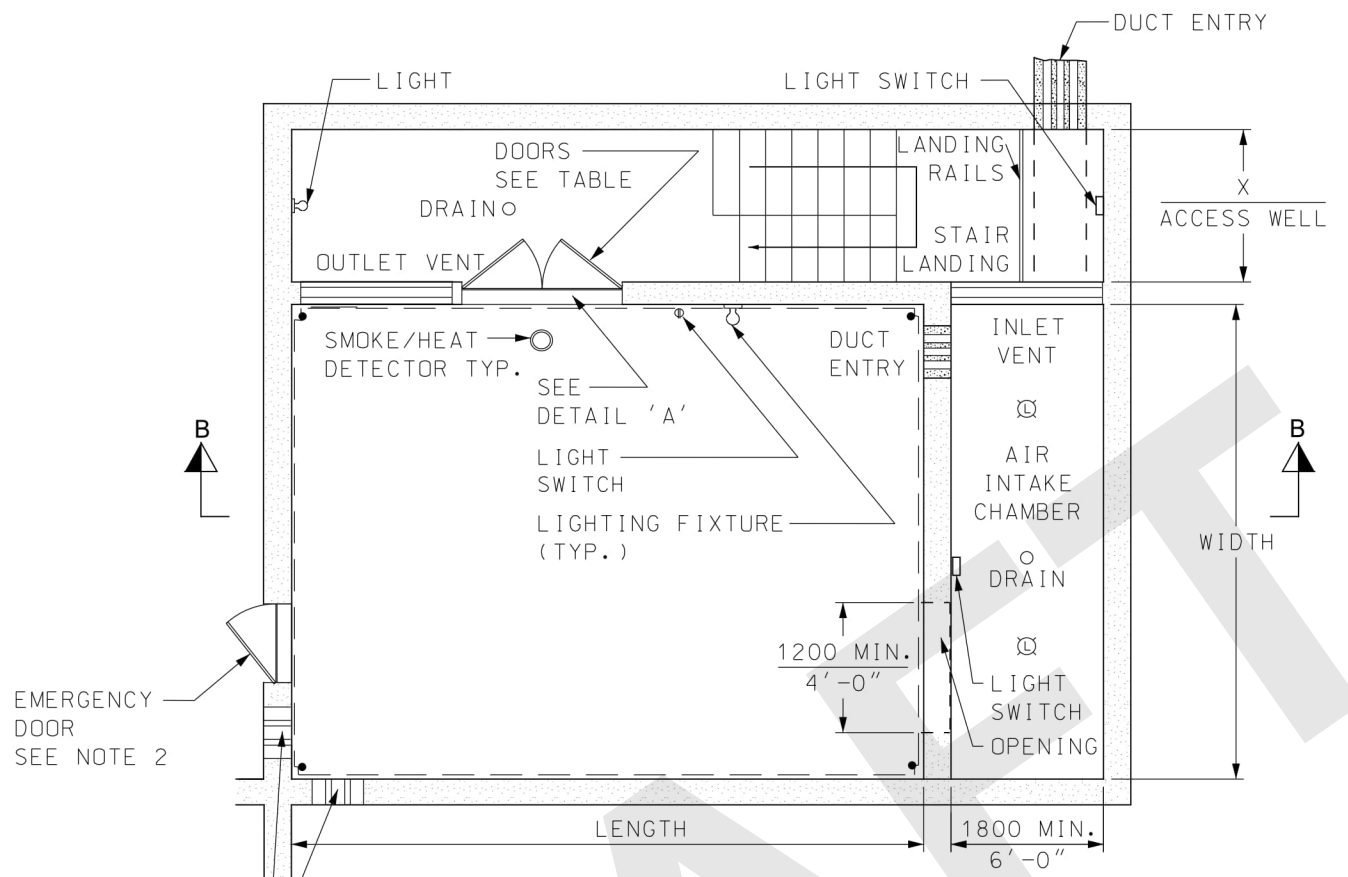

PLAN VIEW
ALTERNATIVE VENTILATION

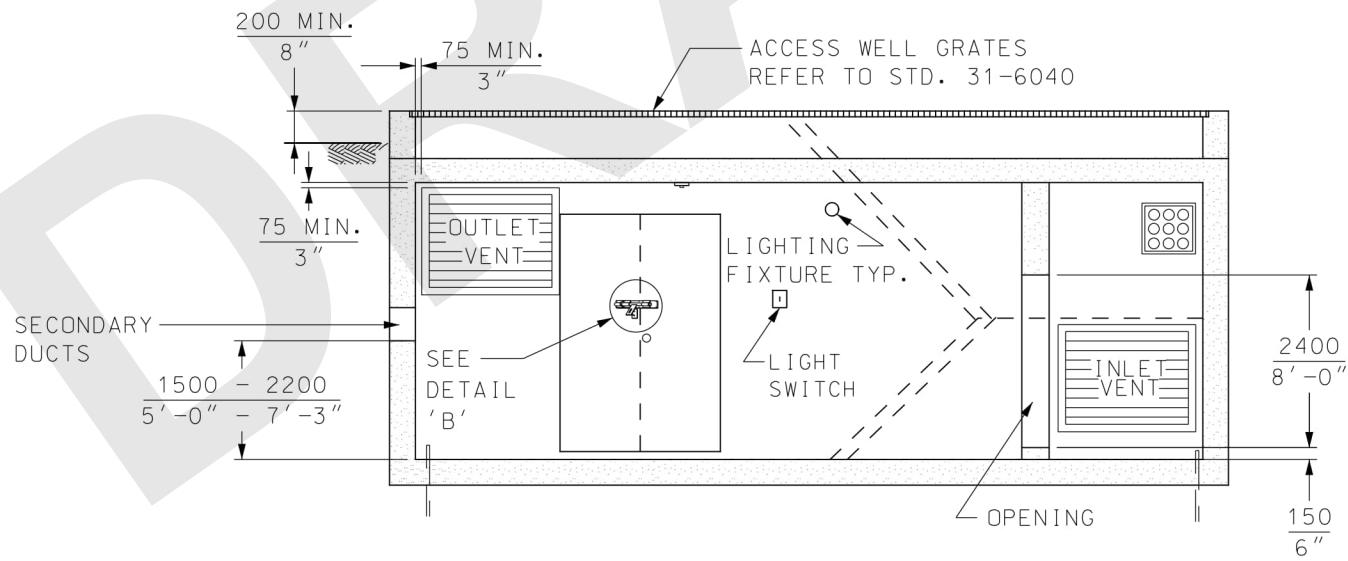

SECTION 'B-B'

DISTRIBUTION CONSTRUCTION STANDARD
Civil Construction

CUSTOMER-OWNED STRUCTURES
BELOW-GRADE WALK-IN VAULT



Approved By:

Drafted By:
B. D.

Designed By:
B. D.

Original Issue:
C. P. 2003-11-27

Scale:
N. T. S.

Rev: 12

31-6030

2/4

© CERTIFIED BY TORONTO HYDRO STANDARD <STANDARDS@TORONTOHYDRO.COM>; THIS DOCUMENT IS FOR USE BY TORONTO HYDRO AND AUTHORIZED PERSONS ONLY AS PER THE TERMS IN TORONTO HYDRO STANDARD 00-0002.

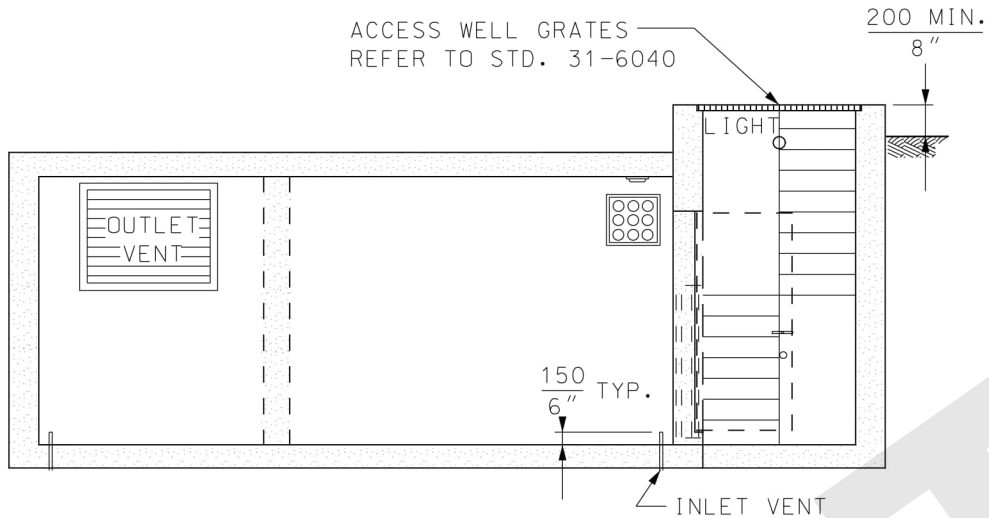

SECTION 'C-C'

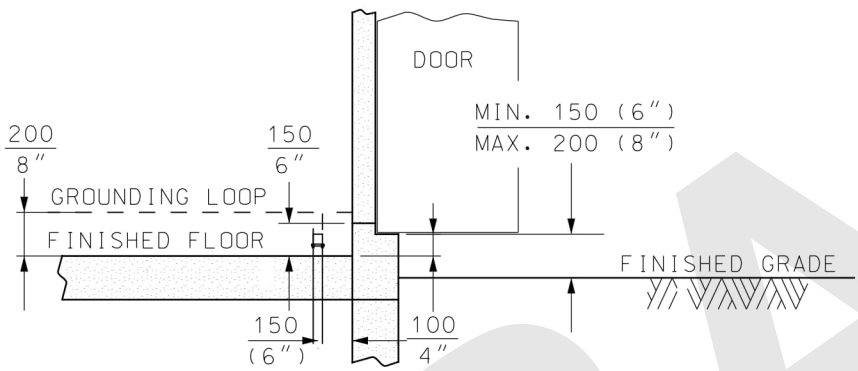

12 **DETAIL 'A'**
DOOR AND GROUNDING DETAIL

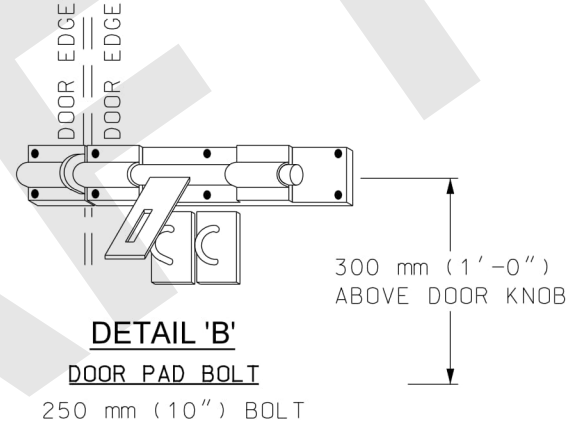

ABOVE GRADE - WALK-IN VAULT SIZES						
TYPE	TX. RATING	LENGTH	WIDTH	X ACCESS WELL	DOORS	ELECTRICAL EQUIPMENT
1	UP TO 2000 kVA	8000 (26'-3")	6000 (19'-8")	1900 (6'-3")	1200x2400 HIGH (4'x8')	12 REFER TO SECTION 13 STANDARDS FOR DETAILS
2	2500 - 4000 kVA	10000 (32'-0")	8000 (26'-3")	3000 (10'-0")	1200x3000 HIGH (4'x10')	

ABOVE GRADE - WALK-IN VAULT MIN. LOADING (SUSPENDED SLAB)				
TYPE	TX. RATING	ROOM AREA	12 * DEAD LOAD (APPROXIMATE)	12 LIVE LOAD
1	UP TO 2000 kVA	48 m ²	12 17,110 kg	REFER TO ONATRIO BUILDING CODE FOR DETAILS
2	2500 - 4000 kVA	80 m ²	12 30,200 kg	

12 * DEAD LOAD = TOTAL AGGREGATE WEIGHT OF ELECTRICAL EQUIPMENT X 1.2 SAFETY FACTOR (ELECTRICAL EQUIPMENT = TRANSFORMERS WITH OR WITHOUT PROTECTORS)

DISTRIBUTION CONSTRUCTION STANDARD
Civil Construction

CUSTOMER-OWNED STRUCTURES
BELOW-GRADE WALK-IN VAULT



Approved By:

Drafted By:
B. D.

Designed By:
B. D.

Original Issue:
C. P. 2003-11-27

Scale:
N. T. S.

Rev: 12

31-6030

3/4

© CERTIFIED BY TORONTO HYDRO STANDARD <STANDARDS@TORONTOHYDRO.COM>; THIS DOCUMENT IS FOR USE BY TORONTO HYDRO AND AUTHORIZED PERSONS ONLY AS PER THE TERMS IN TORONTO HYDRO STANDARD 00-0002.

NOTES:

- 12 1) THIS DRAWING SHALL BE READ IN CONJUNCTION WITH THE LATEST REVISION OF TORONTO HYDRO REQUIREMENTS FOR THE DESIGN AND CONSTRUCTION OF CUSTOMER-OWNED STRUCTURES DOCUMENT CONDITION OF SERVICE REF. 5.
- 2) EMERGENCY DOOR IS REQUIRED IN NEW TRANSFORMER VAULTS, LOCATION OF WHICH SHALL BE APPROVED BY TORONTO HYDRO REPRESENTATIVE. EMERGENCY DOOR SHALL HAVE PANIC HARDWARE INSTALLED TO ALLOW DOOR TO OPEN FROM THE INSIDE. THERE SHALL BE NO METHOD OF OPENING AN EMERGENCY DOOR FROM THE OUTSIDE.
- 3) LOCATION OF ELECTRICAL LIGHT FIXTURE CAN BE INSTALLED AS SHOWN OR AN ALTERNATE LOCATION CAN BE CHOSEN PROVIDED ADEQUATE SPACE AND CLEARANCE IS PROVIDED TO ALLOW FOR PROPER OPERATION AND MAINTENANCE OF ELECTRICAL EQUIPMENT.
- 4) DOORS, LOUVER, SECURITY BARS AND ANY METAL PRODUCT SHALL BE GROUNDED BY CONNECTING 2/0 FLEX STRANDED COPPER TO THE GROUNDING LOOP. CONNECTION SHALL BE BY USING PARALLEL GROOVE CLAMPS AND GROUNDING LUG.
- 5) FOR ADJACENT ELECTRICAL ROOMS, COLLECTOR BUSES OR BUS STUBS CAN BE INSTALLED INSTEAD OF DUCTS AT A MINIMUM HEIGHT OF 2134 mm (7'-0") ABOVE FINISHED FLOOR WITH 600 mm (1'-11⁵/₈") CLEARANCE ON EITHER SIDE TO ALLOW PROPER TERMINATION OF CABLES. COLLECTOR BUS TO BE INSTALLED AS PER SECTION 13 AND ALLOW PROPER UNHINDERED OPERATION AND ACCESS OF EQUIPMENT. SEE STD. 15-1500 FOR COLLECTOR BUS DETAILS.
- 6) FOR SUSPENDED SLAB DESIGN, DEFINED LOAD CAPACITY IS TO BE A MINIMUM. THE VAULT DESIGN MUST COMPLY WITH THE MOST RECENT VERSION OF THE ONTARIO BUILDING CODE (OBC) AND BE SEALED BY A PROFESSIONAL ENGINEER OF ONTARIO. INCREASED CAPACITY MAY BE REQUIRED DEPENDING ON EXTERNAL FACTORS OR JOINT USE EQUIPMENT ROOMS.
- 7) ALL LISTED KVA RATINGS ARE AGGREGATED.
- 8) SAFETY FACTOR (S.F.) OF 1.2 SHALL BE ASSUMED IN THE DEAD LOAD CALCULATIONS
- 9) FOR SCENARIOS WITH TRANSFORMER CAPACITY GREATER THAN 4 MVA, CUSTOMER TO ATTAIN EQUIPMENT SHOP DRAWINGS AND DETERMINE THE REQUIRED LOADING OUTSIDE OF THE LISTED REQUIREMENTS.
- 12 10) GROUND RODS SHALL BE A MINIMUM 3000 mm (10'-0") APART.

DRAFT

DISTRIBUTION CONSTRUCTION STANDARD
Civil Construction

**CUSTOMER-OWNED STRUCTURES
BELOW-GRADE WALK-IN VAULT**



Approved By:

Drafted By:
B. D.

Designed By:
B. D.

Original Issue:
C. P. 2003-11-27

Scale:
N. T. S.

Rev: 12

31-6030

4/4

© CERTIFIED BY TORONTO HYDRO STANDARD <STANDARDS@TORONTOHYDRO.COM>; THIS DOCUMENT IS FOR USE BY TORONTO HYDRO AND AUTHORIZED PERSONS ONLY AS PER THE TERMS IN TORONTO HYDRO STANDARD 00-0002.

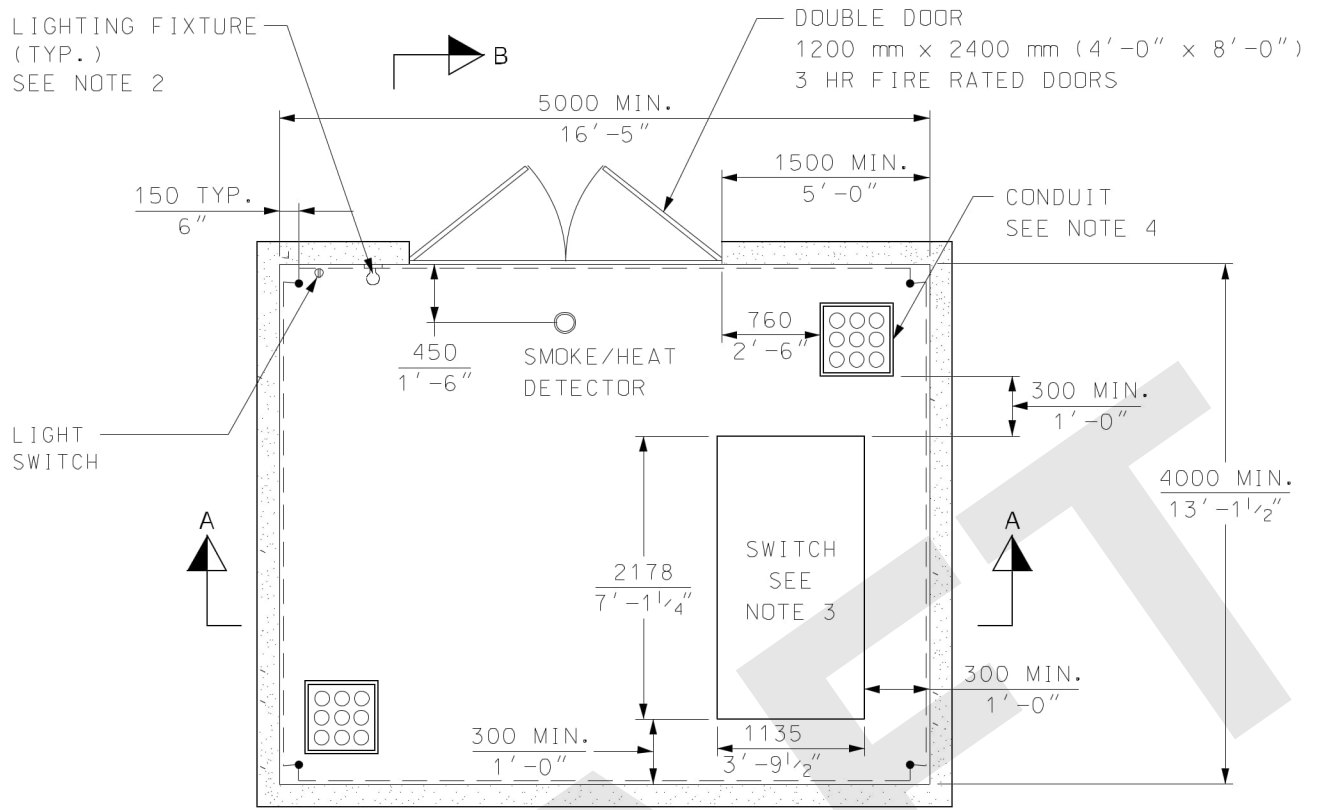

PLAN VIEW

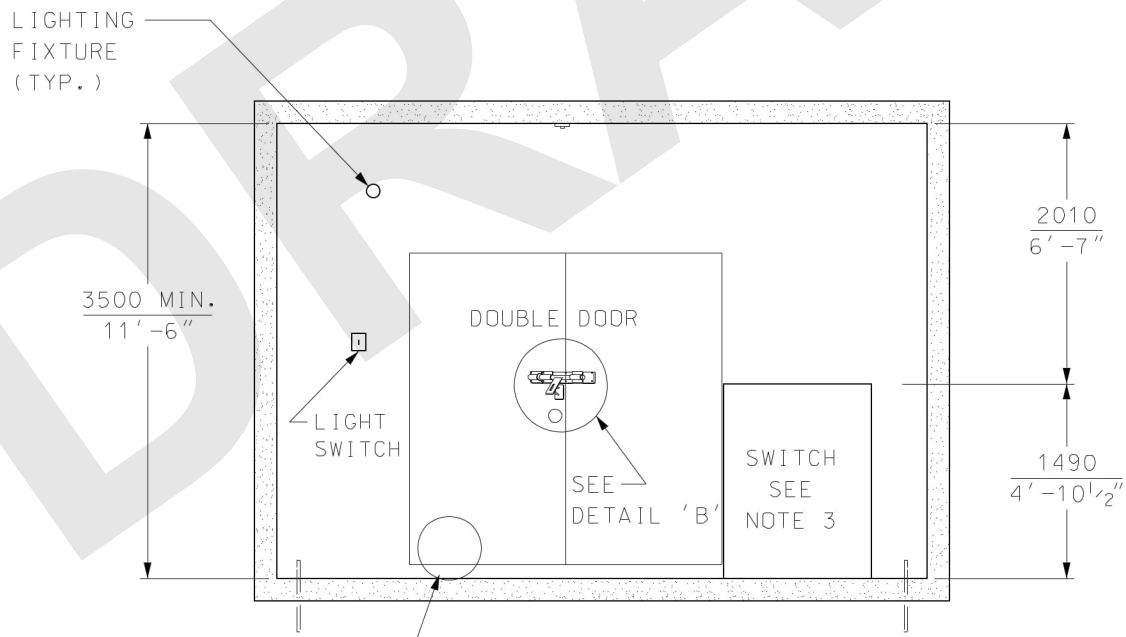

SECTION 'A-A'

DISTRIBUTION CONSTRUCTION STANDARD
Civil Construction

CUSTOMER-OWNED STRUCTURES

ABOVE-GRADE WALK-IN OR BELOW GRADE SWITCHING VAULT



Approved By:
B.D. 2020-09-25

Drafted By: B.D.
Designed By: B.D.

Original Issue:
J.D. 2013-02-11

Scale:
N.T.S.

Rev:

3

31-6035

1/2

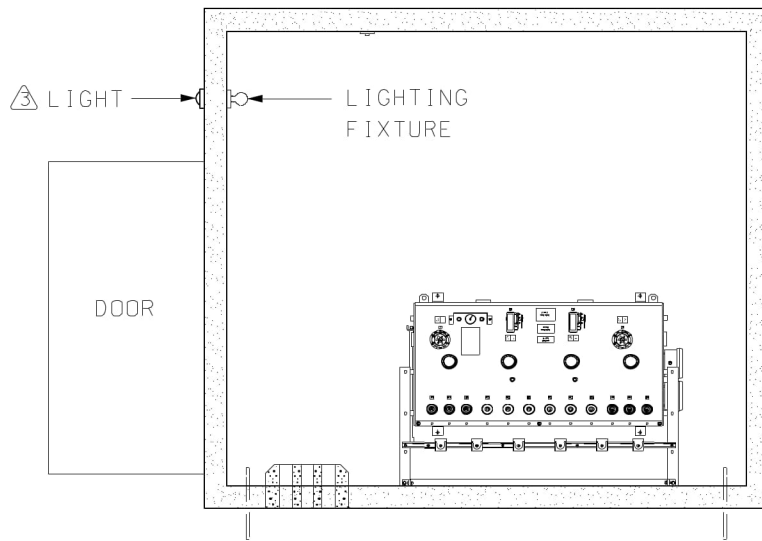

SECTION 'B-B'

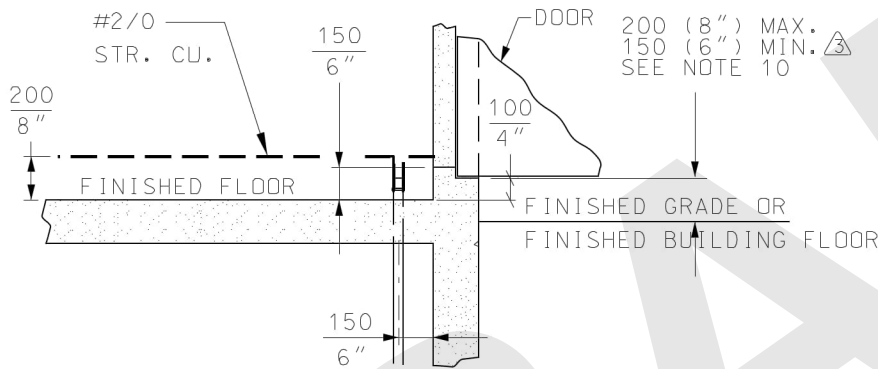

DETAIL 'A'

DOOR AND GROUNDING DETAIL

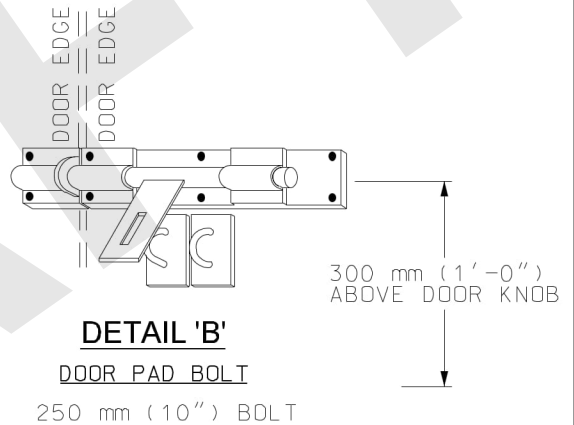

DETAIL 'B'

DOOR PAD BOLT

250 mm (10") BOLT

NOTES:

- 1) THIS DRAWING SHALL BE READ IN CONJUNCTION WITH THE TORONTO HYDRO REQUIREMENTS FOR THE DESIGN AND CONSTRUCTION OF CUSTOMER-OWNED STRUCTURES DOCUMENT.
- 2) LIGHTING SHALL BE INSTALLED AS PER CUSTOMER-OWNED STRUCTURES DOCUMENT. LIGHTING SHALL BE LOCATED SO THAT THERE IS ADEQUATE SPACE FOR THE RELAMPING OR MAINTENANCE.
- 3) LOCATION OF ELECTRICAL EQUIPMENT CAN BE INSTALLED AS SHOWN OR AN ALTERNATE LOCATION CAN BE CHOSEN PROVIDED ADEQUATE SPACE AND CLEARANCE IS PROVIDED TO ALLOW FOR PROPER OPERATION AND MAINTENANCE OF ELECTRICAL EQUIPMENT. REFER TO STD. 13-7840 FOR SWITCH DIMENSIONS.
- 4) LOCATION OF INCOMING AND OUTGOING CONDUIT ONLY SHOWN FOR GUIDELINE PURPOSES.
- 5) SWITCH VAULTS DO NOT REQUIRE VENTILATION.
- 6) REFER TO STD. 31-6040 FOR BELOW GRADE VAULT STAIR AND ACCESS WELL DETAILS.
- 7) IF REQUIRED, AN EMERGENCY DOOR CAN BE INSTALLED WITH APPROVAL FROM TORONTO HYDRO.
- 8) EMERGENCY DOOR SHALL HAVE PANIC HARDWARE INSTALLED TO ALLOW DOOR TO OPEN FROM THE INSIDE. THERE SHALL BE NO METHOD OF OPENING AN EMERGENCY DOOR FROM THE OUTSIDE.
- 9) DOORS, LOUVER, SECURITY BARS AND ANY METAL PRODUCT SHALL BE GROUNDED BY CONNECTING #2/0 FLEX STRANDED COPPER TO THE GROUNDING LOOP. CONNECTION SHALL BE BY USING PARALLEL GROOVE CLAMPS AND GROUNDING LUG.
- 10) HEIGHT OF CURB AT EXTERIOR THRESHOLD OF DOOR SHALL BE MINIMUM 150 mm (6") AND MAXIMUM 200 mm (8") WHEN FACING EXTERIOR FINISHED GRADE. IF VAULT EXIT IS WITHIN BUILDING, MINIMUM 100 mm (4") CURB SHALL BE MAINTAINED.

DISTRIBUTION CONSTRUCTION STANDARD
Civil Construction

CUSTOMER-OWNED STRUCTURES

ABOVE-GRADE WALK-IN OR BELOW GRADE SWITCHING VAULT



Approved By:
B.D. 2020-09-25

Drafted By:
B.D.

Designed By:
B.D.

Original Issue:
J.D. 2013-02-11

Scale:
N.T.S.

Rev. **3**

31-6035

2/2

© CERTIFIED BY TORONTO HYDRO STANDARD <STANDARDS@TORONTOHYDRO.COM>, THIS DOCUMENT IS FOR USE BY TORONTO HYDRO AND AUTHORIZED PERSONS ONLY AS PER THE TERMS IN TORONTO HYDRO STANDARD 00-0002.

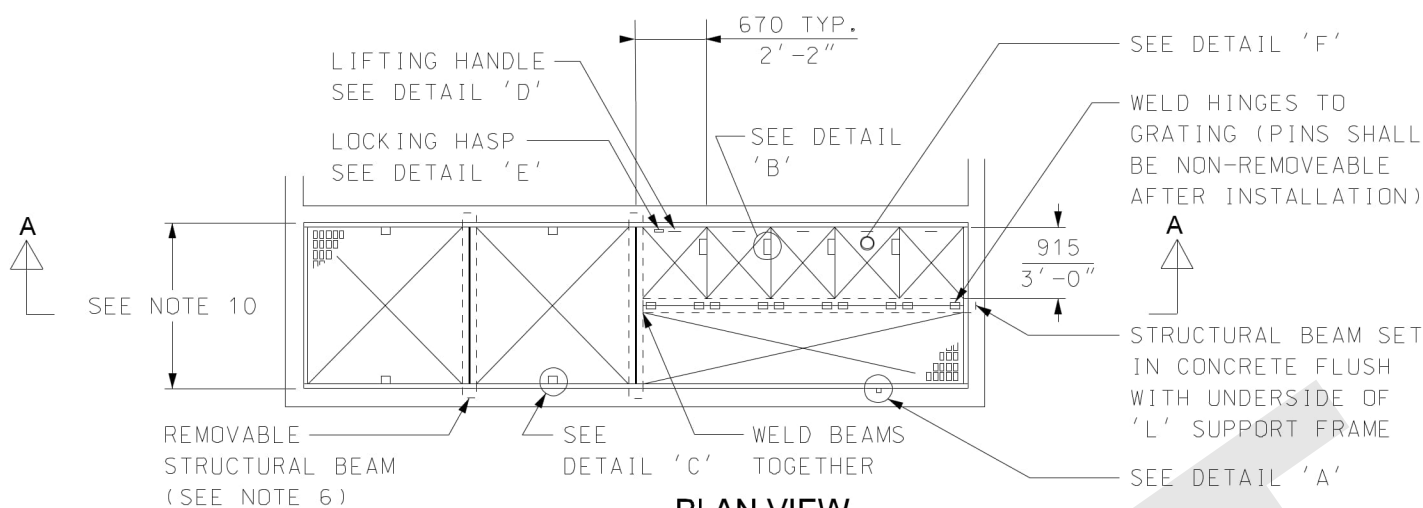

**PLAN VIEW
ACCESS WELL COVER ASSEMBLY**

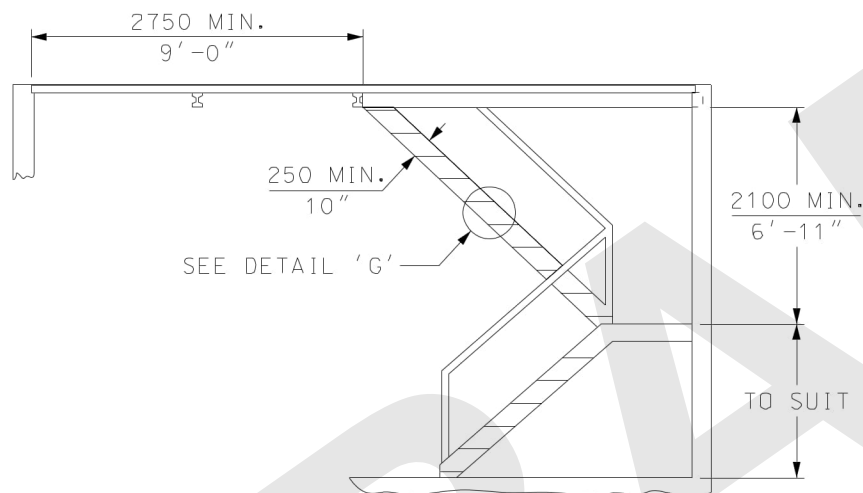

SECTION 'A-A'

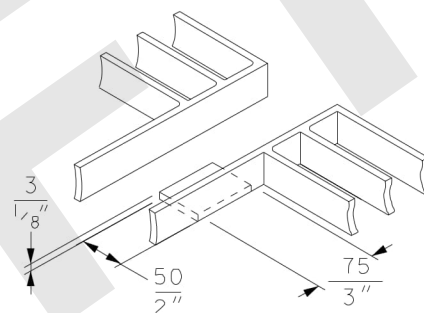

**DETAIL 'B'
HOLD DOWN PLATES**

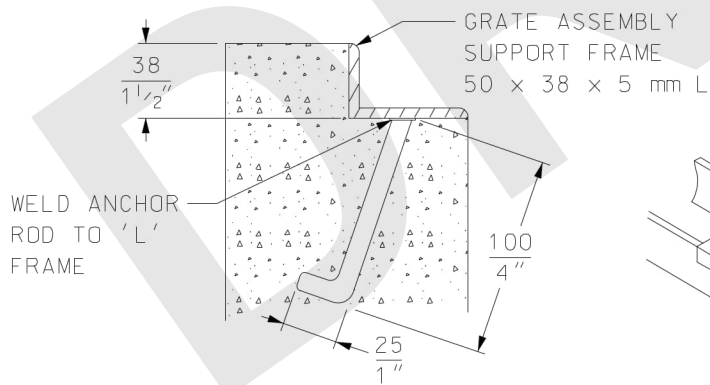

ANCHOR ROD MATERIAL SHALL BE 10M REINFORCING STEEL SPACED AT 1.0 m (3'-4") MAX. COMPLETELY AROUND FRAME.

**DETAIL 'A'
ANCHOR ROD**

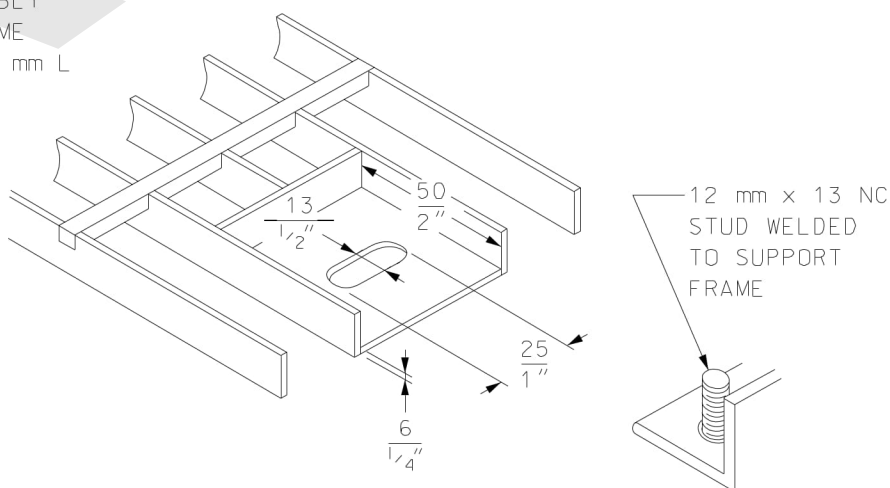

**DETAIL 'C'
BOLT PAD FOR STUD AND PENTA-HEAD NUT**

DISTRIBUTION CONSTRUCTION STANDARD
Civil Construction



Approved By:
B.D. 2019-03-22
Drafted By:
N.H.
Designed By:
B.D.

Original Issue:
G.D./C.P. 2003-11-27

Scale:
N.T.S.

Rev:
4

31-6040

1/2

**CUSTOMER-OWNED STRUCTURES
STAIR AND ACCESS WELL DETAIL
FOR BELOW-GRADE VAULTS**

© CERTIFIED BY TORONTO HYDRO STANDARD <STANDARDS@TORONTOHYDRO.COM>; THIS DOCUMENT IS FOR USE BY TORONTO HYDRO AND AUTHORIZED PERSONS ONLY AS PER THE TERMS IN TORONTO HYDRO STANDARD 00-0002.

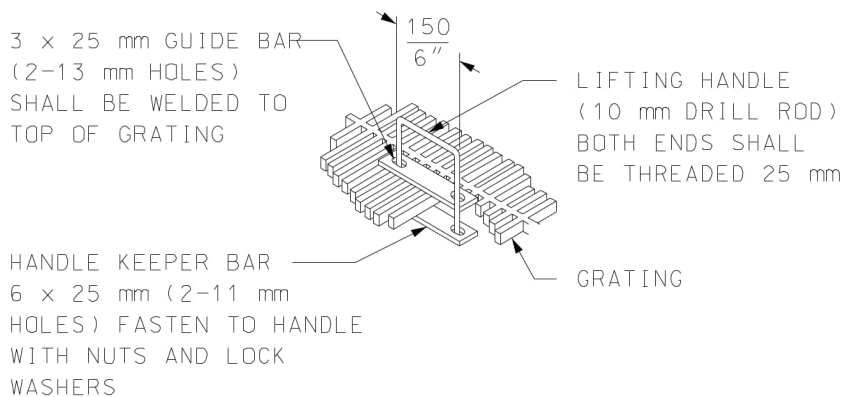

DETAIL 'D'
GRATE LIFTING HANDLE

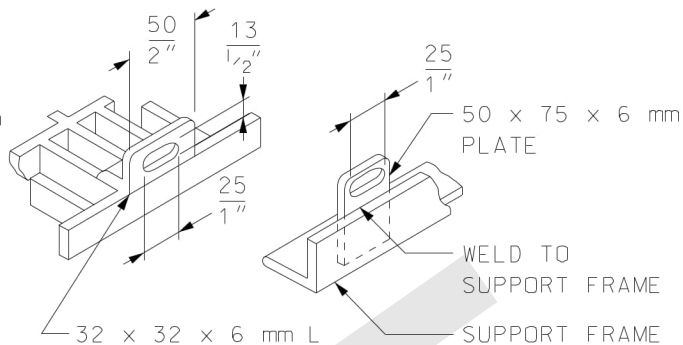

DETAIL 'E'
TYPICAL GRATE LOCKING HASP

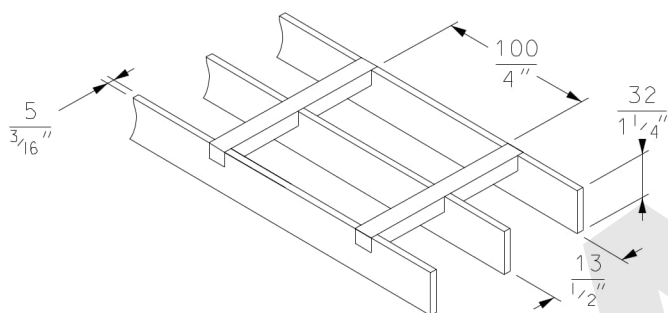

WEIGHT 9 lbs/SQ. FT. MAX. ⚠

DETAIL 'F'
TYPICAL GRATING

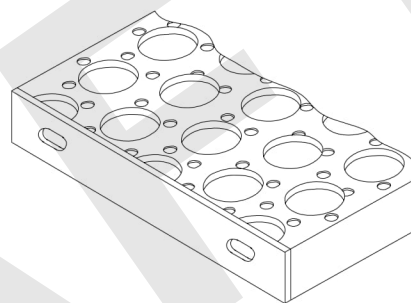

DETAIL 'G'
SAFETY GRIP STAIR TREAD

NOTES:

- ⚠ 1) ACCESS WELL COVER (GRATINGS AND BEAMS) SHOWN IN THIS STANDARD ARE FOR TYPICAL VAULTS LOCATED IN PEDESTRIAN TRAFFIC ONLY. CUSTOMER'S ENGINEER SHALL BE RESPONSIBLE FOR DESIGN OF OVERALL COVER (GRATINGS AND BEAMS) BASED ON VAULT LOCATION AND LOADING REQUIREMENTS. ALL SHOP DRAWINGS SHALL BE STAMPED BY CUSTOMER'S ENGINEER OR MANUFACTURER PRIOR TO BEING ACCEPTED BY TORONTO HYDRO FOR INSTALLATION.
- 2) ALL METAL COMPONENTS SHALL BE HOT DIPPED GALVANIZED AS PER CSA G-164. CLEANED, PRIMED AND PAINTED AFTER WELDING.
- ⚠ 3) ACCESS WELL SHALL BE COMPLETE WITH STANDARD GRATING TYPE 'BB-6' AS MANUFACTURED BY BORDEN METAL PRODUCTS AS APPROVED EQUIVALENT.
- 4) LOCKING HASPS FOR GRATING SHALL BE SUPPLIED BY OWNER AS PER DIAGRAM. LOCKS SHALL BE SUPPLIED BY TORONTO HYDRO.
- 5) PENTA-HEAD NUTS ARE REQUIRED FOR GRATING.
- 6) BEAM SHALL BE SEATED IN A SUITABLE SADDLE (METAL OR CONCRETE) WITH NO FASTENING DEVICES (BOLTS).
- ⚠ 7) CUSTOMER'S ENGINEER SHALL BE RESPONSIBLE FOR DESIGN OF STAIRS, HANDRAIL AND GUARDS AS PER ONTARIO BUILDING CODE REQUIREMENTS FOR AN EXIT STAIR.
- 8) STAIRS, HANDRAIL AND GUARDS SHALL BE OF ALL METAL CONSTRUCTION WITH WELDED JOINTS AND SHALL BE HOT DIPPED GALVANIZED AS PER CSA SPEC. G-164.
- 9) STAIR TREADS AND LANDING SHALL BE AMICO-ISG SAFETY GRIP GRATING OR APPROVED EQUIVALENT.
- 10) REFER TO STD. 31-6030 FOR ACCESS WELL DETAILS. WIDTH OF GRATING SHALL SUIT THE WIDTH OF ACCESS WELL.
- 11) ALL GRATINGS SHALL BE BOLTED DOWN.

DISTRIBUTION CONSTRUCTION STANDARD
Civil Construction

**CUSTOMER-OWNED STRUCTURES
STAIR AND ACCESS WELL DETAIL
FOR BELOW-GRADE VAULTS**



Approved By:
B. D. 2019-03-22

Drafted By: N. H.
Designed By: B. D.

Original Issue:
G. D. / C. P. 2003-11-27

Scale:
N. T. S.

Rev: 4

31-6040

2/2

© CERTIFIED BY TORONTO HYDRO STANDARD <STANDARDS@TORONTOHYDRO.COM>; THIS DOCUMENT IS FOR USE BY TORONTO HYDRO AND AUTHORIZED PERSONS ONLY AS PER THE TERMS IN TORONTO HYDRO STANDARD 00-0002.

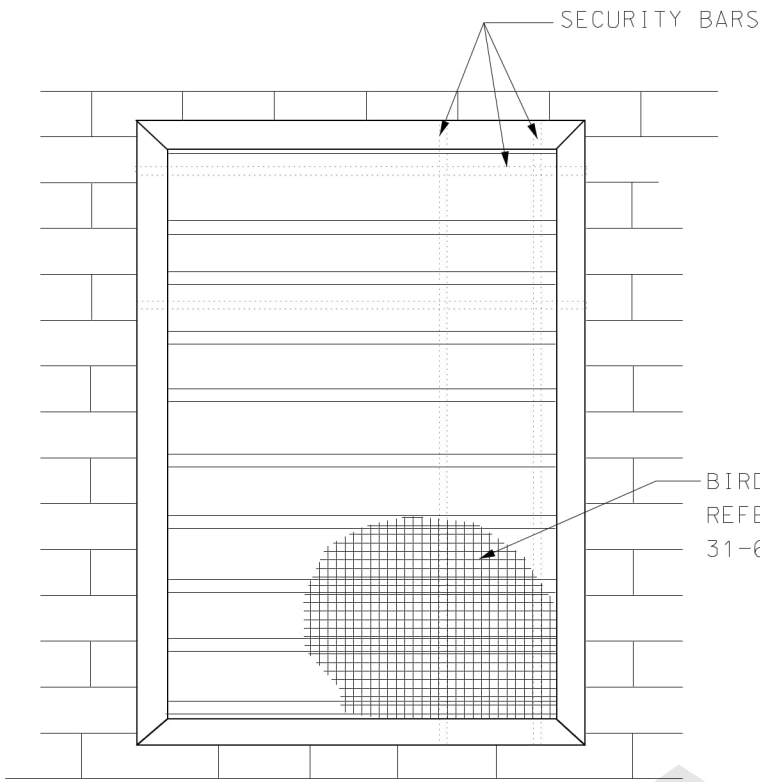

LOUVER FRONT VIEW

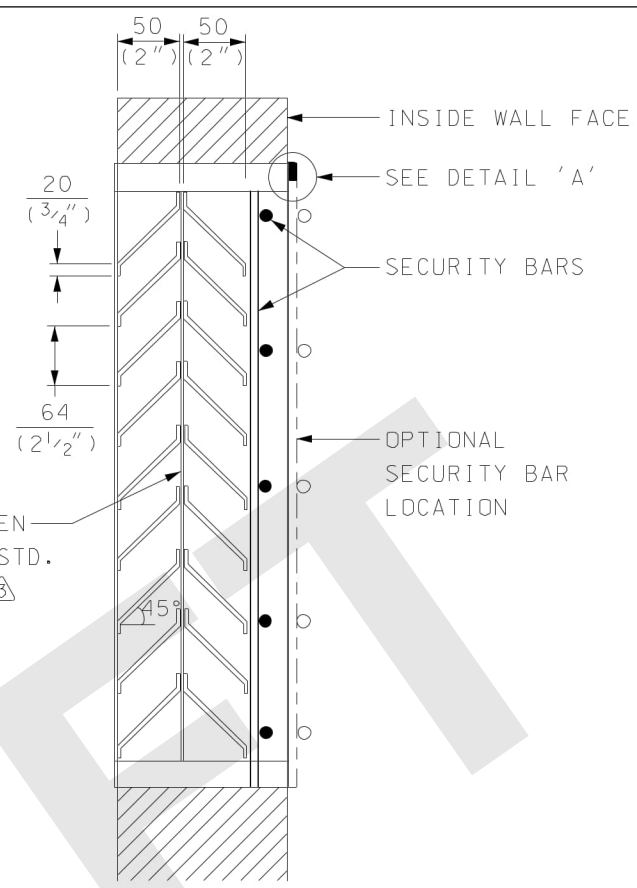

LOUVER AND SECURITY BARS CROSS SECTION

15M
SECURITY BAR
SEE NOTE 5

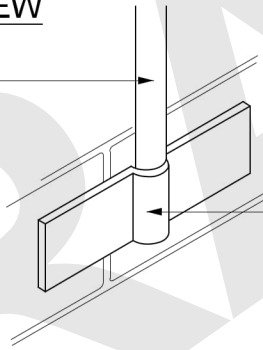

SECURITY BARS SHALL BE WELDED FLAT BAR

DETAIL 'A'

NOTES:

- 1) VAULTS SHALL BE PROVIDED WITH A NATURAL CROSS VENTILATION SYSTEM TO PREVENT THE AMBIENT TEMPERATURE IN THE VAULT FROM EXCEEDING 40 DEG. CELSIUS.
- 2) NET AREA OF VENTILATION OPENINGS (INLET AND OUTLET) SHALL NOT BE LESS THAN 20 cm² (3 in²) PER KVA.
- 3) VENT OPENINGS SHALL HAVE 64 mm (2 1/2") SPACED GABLED DOUBLE LOUVER VENT. CONSTRUCTION SHALL BE OF MINIMUM 16 GAUGE STEEL USING 13 mm (1/2") SQUARE MESH BIRD SCREEN.
- 4) SHOP DRAWINGS SHALL BE REVIEWED AND ACCEPTED BY TORONTO HYDRO BEFORE FABRICATION.
- 5) 15M SECURITY BARS SHALL BE MOUNTED ON WALL, SPACED AT 200 mm (8") CENTERS WITH WELDS AT INTERSECTING POINTS. AS AN ALTERNATIVE, SECURITY BARS CAN BE LAGGED INTO TRANSFORMER VAULT WALL.
- 6) ALL STEEL SHALL BE OF METAL CONSTRUCTION WITH WELDED JOINTS.
- 7) ALL STEEL SHALL BE HOT DIPPED GALVANIZED AFTER FABRICATION AS PER CSA G-164.
- 8) LOUVER, SECURITY BARS SHALL BE GROUNDED BY CONNECTING #2/0 FLEX STRANDED COPPER TO THE GROUNDING LOOP. CONNECTION TO THE METAL PRODUCTS SHALL BE BY USING PARALLEL GROOVE CLAMPS AND GROUNDING LUG.

DISTRIBUTION CONSTRUCTION STANDARD
Civil Construction

**CUSTOMER-OWNED STRUCTURES
LOUVER DETAILS FOR VENT OPENINGS**



Approved By:
J.D. 2014-02-04
Drafted By:
K.H.
Designed By:
J.D.

Original Issue:
C.P. 2003-11-27

Scale:
N.T.S.

Rev:
3

31-6050

1/1

© CERTIFIED BY TORONTO HYDRO STANDARD <STANDARDS@TORONTOHYDRO.COM>; THIS DOCUMENT IS FOR USE BY TORONTO HYDRO AND AUTHORIZED PERSONS ONLY AS PER THE TERMS IN TORONTO HYDRO STANDARD 00-0002.

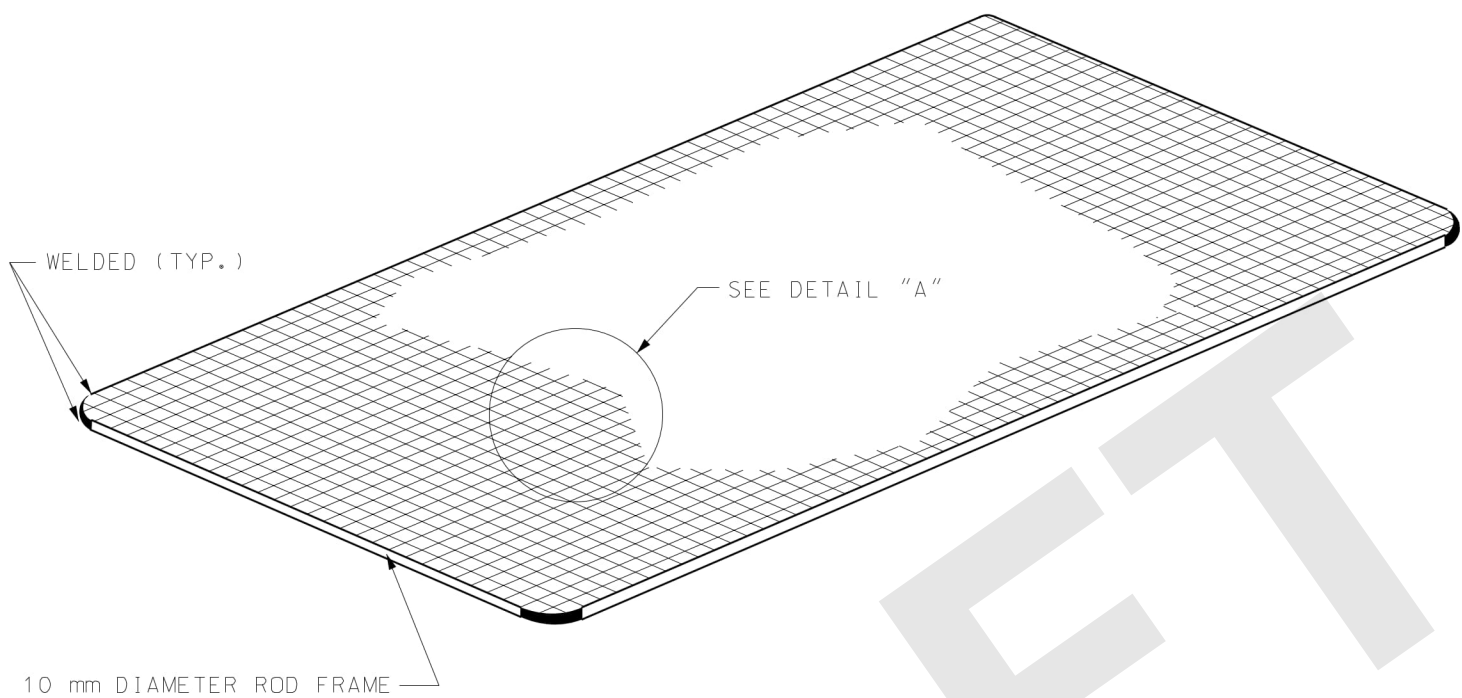

ISOMETRIC VIEW

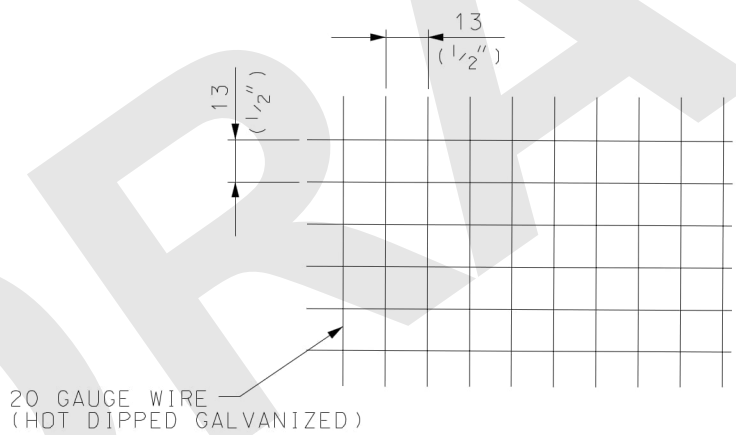

DETAIL "A"

13 mm (1/2") WELDED WIRE MESH

NOTES: ⚠

- 1) BIRD SCREEN TO BE OF METAL CONSTRUCTION WITH WELDED JOINTS.
- 2) BIRD SCREEN AND ALL MOUNTING TO BE HOT DIPPED GALVANIZED AFTER FABRICATION AS PER CSA G-164.
- 3) SHOP DRAWINGS MUST BE REVIEWED AND ACCEPTED BY TORONTO HYDRO BEFORE FABRICATION.

DISTRIBUTION CONSTRUCTION STANDARD
Civil Construction

**CUSTOMER-OWNED STRUCTURES
BIRD SCREEN DETAILS**



Approved By:
J.D. 2013-02-12

Drafted By: D.L.
Designed By: J.D.

Original Issue:
C.P. 2003-11-27

Scale:
N.T.S.

Rev: **2**

31-6060

1/1

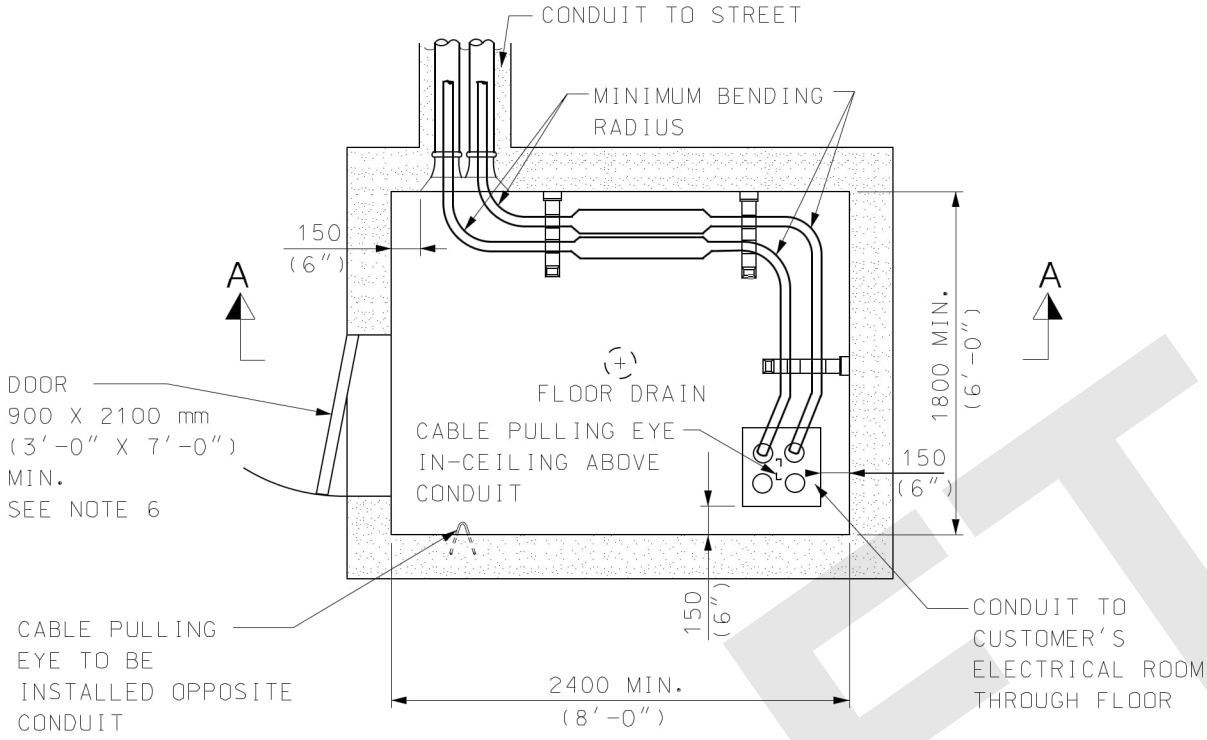

**PLAN VIEW
ROOM FOR HIGH-VOLTAGE CABLES**

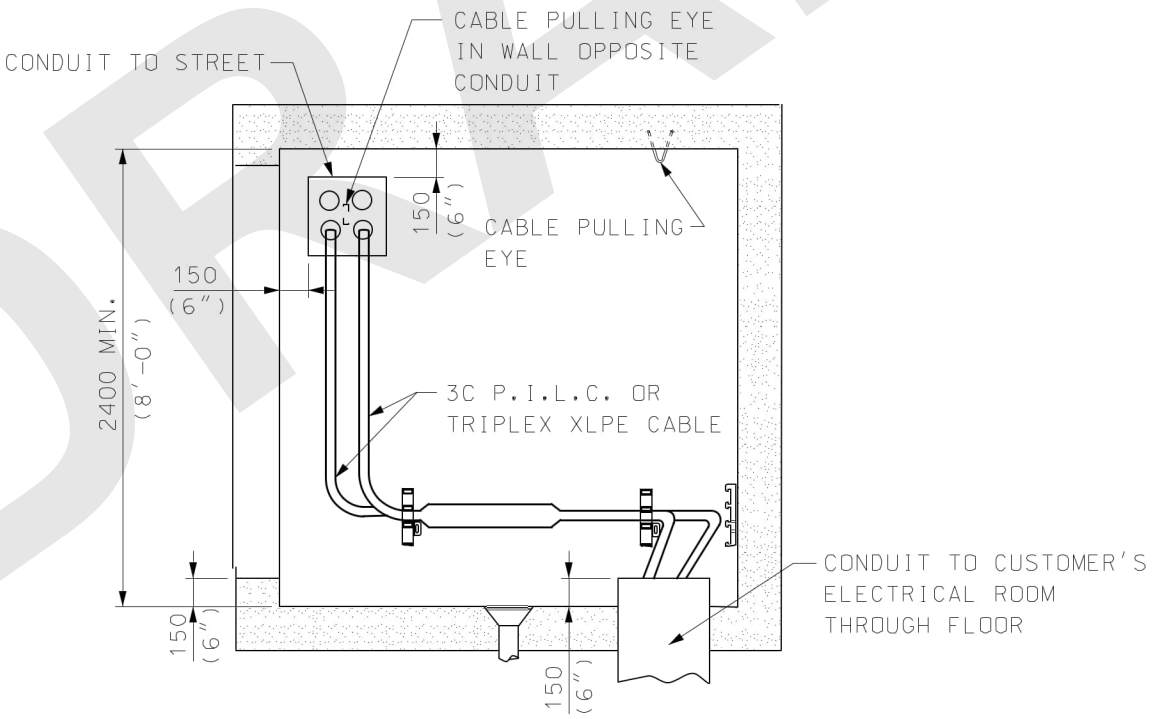

SECTION "A-A"

DISTRIBUTION CONSTRUCTION STANDARD
Civil Construction



Approved By:
J.D. 2013-02-11
Drafted By:
D.L.

Designed By:
J.D.

Original Issue:
G.D./C.P. 2004-07-30

Scale:
N.T.S.

Rev: 3

31-6070

1/3

**CUSTOMER-OWNED STRUCTURES
CABLE PULL ROOMS
TYPICAL INSTALLATION OF HIGH AND LOW VOLTAGE CABLES**

© CERTIFIED BY TORONTO HYDRO STANDARD <STANDARDS@TORONTOHYDRO.COM>; THIS DOCUMENT IS FOR USE BY TORONTO HYDRO AND AUTHORIZED PERSONS ONLY AS PER THE TERMS IN TORONTO HYDRO STANDARD 00-0002.

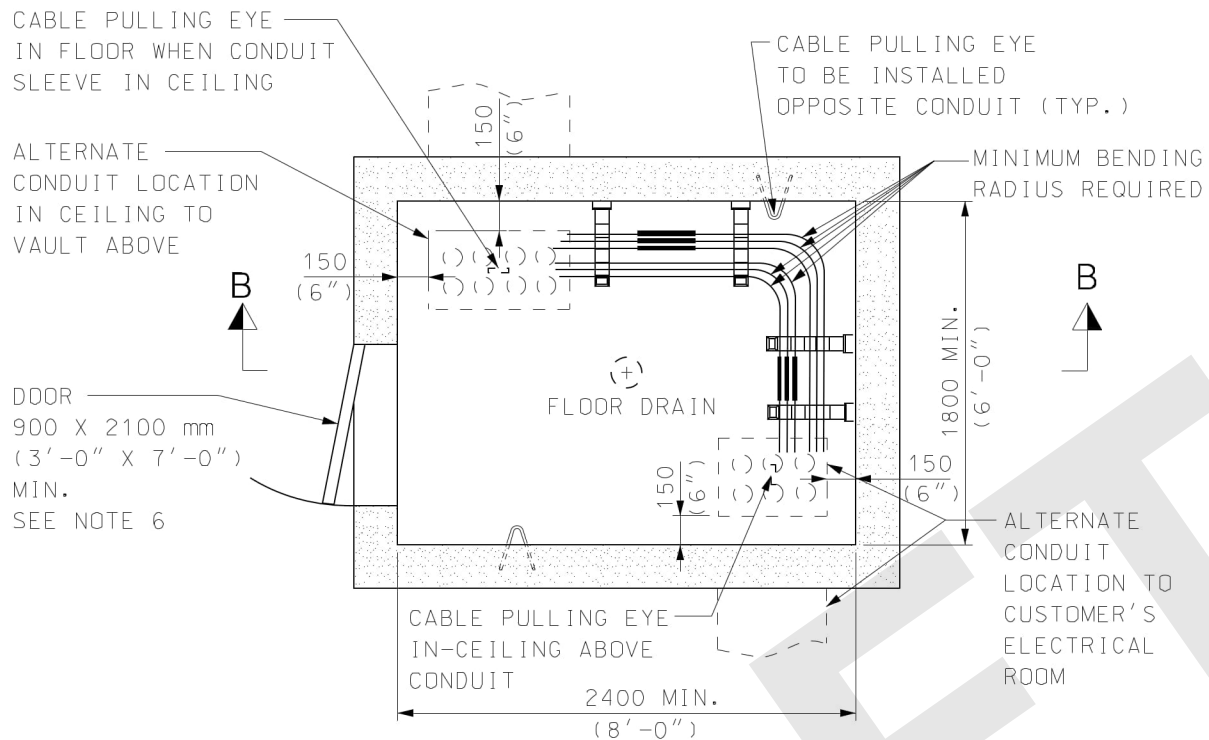

PLAN VIEW
ROOM FOR LOW-VOLTAGE CABLES

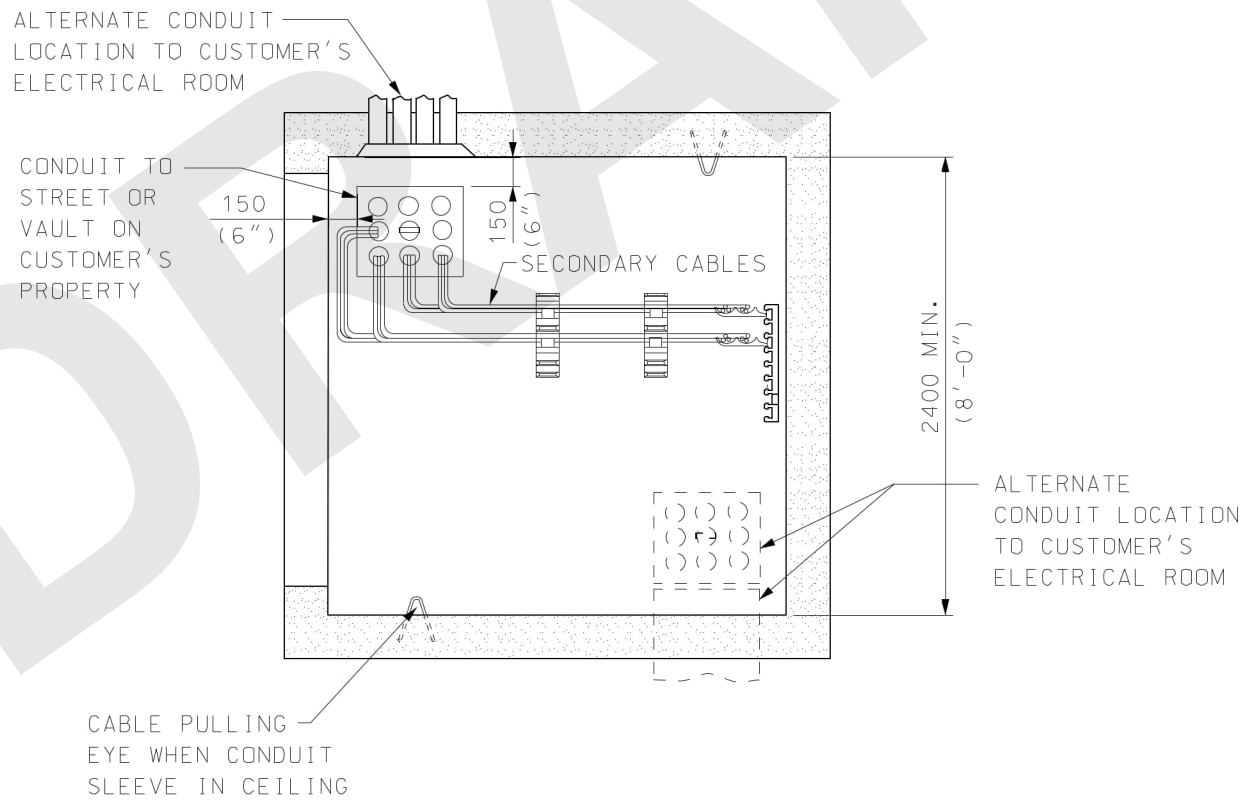

SECTION "B-B"

DISTRIBUTION CONSTRUCTION STANDARD
Civil Construction



Approved By:
J.D. 2013-02-11
Drafted By:
D.L.

Designed By:
J.D.

Original Issue:
G.D./C.P. 2004-07-30

Scale:
N.T.S.

Rev: 3

31-6070

2/3

CUSTOMER-OWNED STRUCTURES
CABLE PULL ROOMS
TYPICAL INSTALLATION OF HIGH AND LOW VOLTAGE CABLES

NOTES: A

- 1) WHEN HIGH VOLTAGE PRIMARY CABLES OR LOW VOLTAGE SECONDARY CABLES ARE ROUTED THROUGH THE CABLE PULL ROOM, THE FOLLOWING POINTS ARE TO BE CONSIDERED IN DETERMINING THE CONSTRUCTION REQUIREMENTS AND GENERAL LAYOUT:
 - A) IN ALL CASES, IT SHALL BE POSSIBLE TO MAKE CABLE JOINTS IN THE ROOM.
 - B) JOINTS IN CABLE SHALL BE HORIZONTAL.
 - C) THE WALL ON WHICH THE CABLE JOINT IS TO BE RACKED SHALL BE LONG ENOUGH TO ACCOMMODATE THE JOINT AND TWO CABLE BENDS. THE CABLE JOINT MUST BE AT LEAST 300 mm (1'-0") FROM THE FLOOR.
- 2) THE WALLS OF THE ROOM SHALL BE AT LEAST 2400 mm (8'-0") LONG AND 1800 mm (6'-0") WIDE, AND THE MINIMUM HEADROOM SHALL BE 2400 mm (8'-0"). LARGER DIMENSIONS ARE REQUIRED WHEN:
 - A) STEPS, RAILINGS, COLUMNS ARE LOCATED IN THE "CLEAR" WORKING AREA.
 - B) MORE THAN 2 CIRCUITS ARE INSTALLED.
 - C) CONDUITS ARE LOCATED SUCH THAT THE CABLES SHALL ENCIRCLE THE PULL ROOM. HEADROOM DIMENSIONS TO INCREASE IN SUCH CASES.
- 3) CABLE PULLING EYES ARE TO BE INSTALLED AND LOCATED AS PER STD. 31-8210.
- 4) THE CONDUIT ENTRANCES SHALL BE LOCATED NEAR THE CORNERS OF THE ROOM AND BE AS FAR APART AS POSSIBLE AND SHALL BE OFFSET FROM EACH OTHER. ALSO, THE DUCTS THAT GO TO THE STREET MUST SLOPE AWAY FROM THE PULL ROOM.
- 5) LIGHTING AND DRAINAGE MUST BE PROVIDED BY THE CUSTOMER. LIGHT TO BE LOCATED IN THE CENTER OF ROOM.
- 6) PULL ROOM TO BE EQUIPPED WITH A DOOR AND FRAME HAVING A FIRE RATING OF 1.5 HOURS.
- 7) WHERE POSSIBLE, THE DOORWAY SHALL BE LOCATED OPPOSITE A DUCT FACE AND POSITIONED SO THAT IT DOES NOT INTERFERE WITH JOINTING OR CABLE INSTALLATION.
- 8) PADLOCK HASP TO BE PROVIDED FOR DOOR (OR PROVISION FOR TORONTO HYDRO CYLINDER LOCK - 29 mm (1'-1/4") DIAMETER CYLINDER).
- 9) NO FOREIGN EQUIPMENT OR PIPES ARE ALLOWED IN THE PULL ROOM.
- 10) CABLE RACKS AND ARMS WILL BE SUPPLIED AND INSTALLED BY TORONTO HYDRO AND CHARGED TO THE CUSTOMER.
- 11) 24 HR. ACCESS IS REQUIRED.
- 12) THE ABOVE REQUIREMENTS ARE TO BE SHOWN ON THE CUSTOMER'S DRAWINGS FOR TORONTO HYDRO'S REVIEW AND ACCEPTANCE.

DISTRIBUTION CONSTRUCTION STANDARD
Civil Construction

**CUSTOMER-OWNED STRUCTURES
CABLE PULL ROOMS
TYPICAL INSTALLATION OF HIGH AND LOW VOLTAGE CABLES**



Approved By:
J.D. 2013-02-11

Drafted By:
D.L.

Designed By:
J.D.

Original Issue:
G.D./C.P. 2004-07-30

Scale:
N.T.S.

Rev: 3

31-6070

3/3

© CERTIFIED BY TORONTO HYDRO STANDARD <STANDARDS@TORONTOHYDRO.COM>; THIS DOCUMENT IS FOR USE BY TORONTO HYDRO AND AUTHORIZED PERSONS ONLY AS PER THE TERMS IN TORONTO HYDRO STANDARD 00-0002.

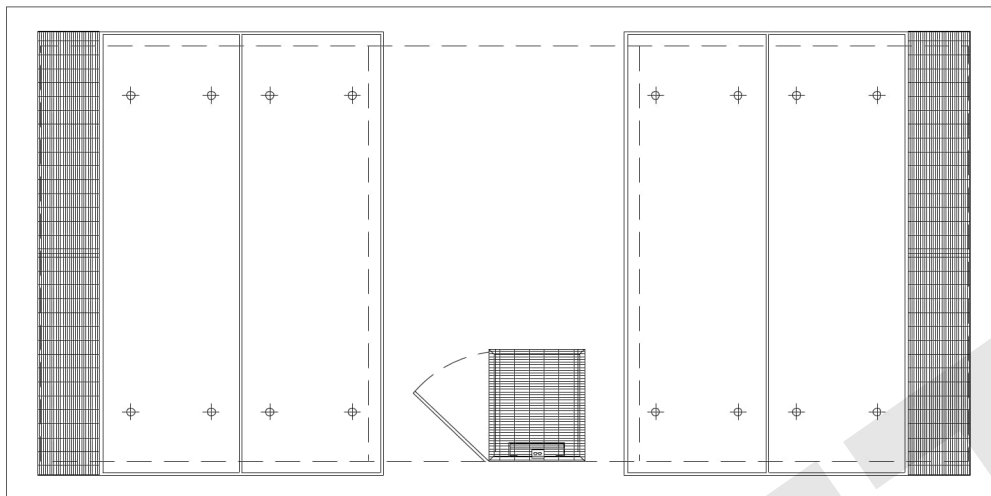

△ BELOW GRADE - TOP ENTRY

- 13-2010 - 4.16 kV (MAX. 3 - 167 kVA TRANSFORMERS) ELECTRICAL EQUIPMENT LAYOUT
- 13-4020 - 13.8 kV COMPACT RADIAL (MAX. 1000 kVA TRANSFORMER) ELECTRICAL EQUIPMENT LAYOUT
- 13-4040 - 13.8 kV COMPACT LOOP (MAX. 1000 kVA TRANSFORMER) ELECTRICAL EQUIPMENT LAYOUT
- 31-5110 - CIVIL STRUCTURE (PROPOSED) - 3000 x 6700 x 3660 mm (10'-0" x 22'-0" x 12'-0")
- 31-5170 - CIVIL STRUCTURE (EXISTING) - 2290 x 6400 x 3660 mm (7'-6" x 21'-0" x 12'-0")

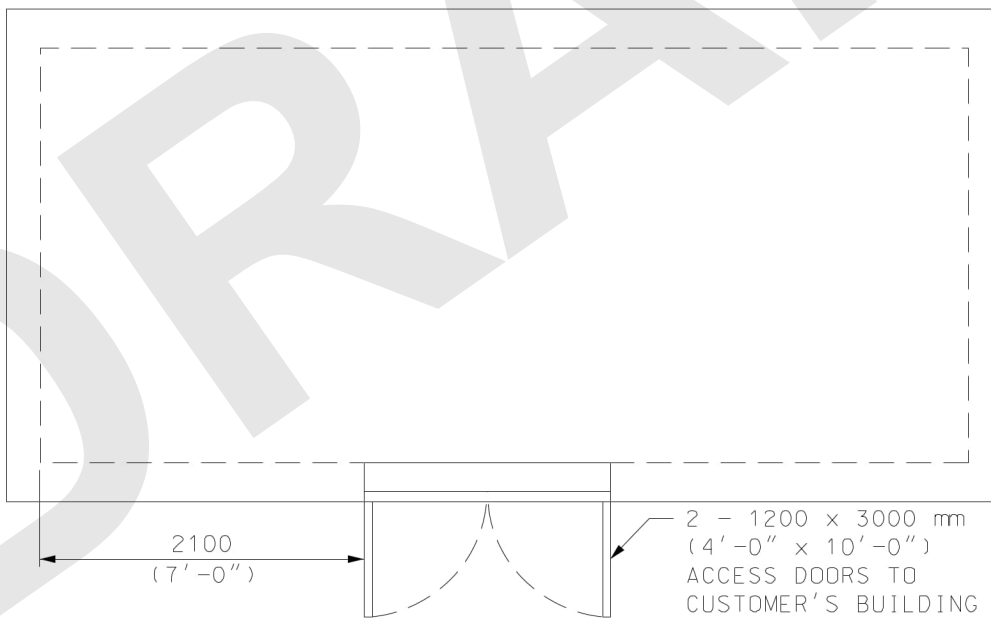

△ ABOVE GRADE - WALK-IN

- 13-2010 - 4.16 kV (MAX. 3 - 167 kVA TRANSFORMERS) ELECTRICAL EQUIPMENT LAYOUT
- 13-4040 - 13.8 kV COMPACT LOOP (MAX. 2000 kVA TRANSFORMER) ELECTRICAL EQUIPMENT LAYOUT
- CIVIL STRUCTURE - 3000 x 7300 x 3660 mm (10'-0" x 24'-0" x 12'-0")

DISTRIBUTION CONSTRUCTION STANDARD
Civil Construction

CUSTOMER-OWNED STRUCTURES



4.16 kV - 13.8 kV TRANSFORMER VAULTS



Approved By:
J. D. 2014-02-04

Drafted By:
K. H.

Designed By:
J. D.

Original Issue:
C. P. / G. D. 2003-11-27

Scale:
N. T. S.

Rev:
4

31-6080

1/3

© CERTIFIED BY TORONTO HYDRO STANDARD <STANDARDS@TORONTOHYDRO.COM>; THIS DOCUMENT IS FOR USE BY TORONTO HYDRO AND AUTHORIZED PERSONS ONLY AS PER THE TERMS IN TORONTO HYDRO STANDARD 00-0002.

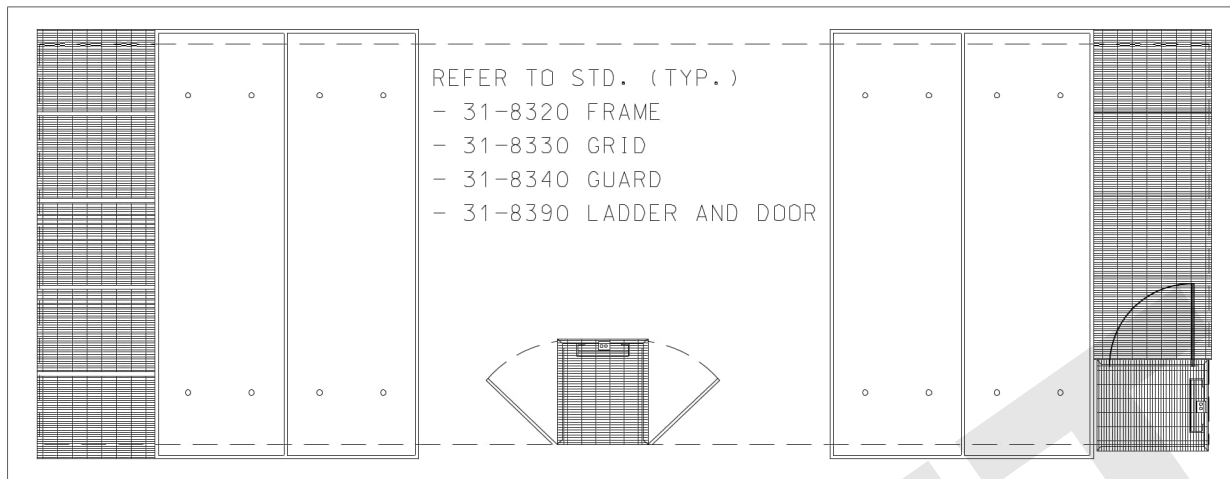

⚠ BELOW GRADE - TOP ENTRY

13-4010 - 13.8 kV RADIAL (MAX. 2500 kVA TRANSFORMER) ELECTRICAL EQUIPMENT LAYOUT
 CIVIL STRUCTURE - 3000 x 8530 x 3660 mm (10'-0" x 28'-0" x 12'-0")

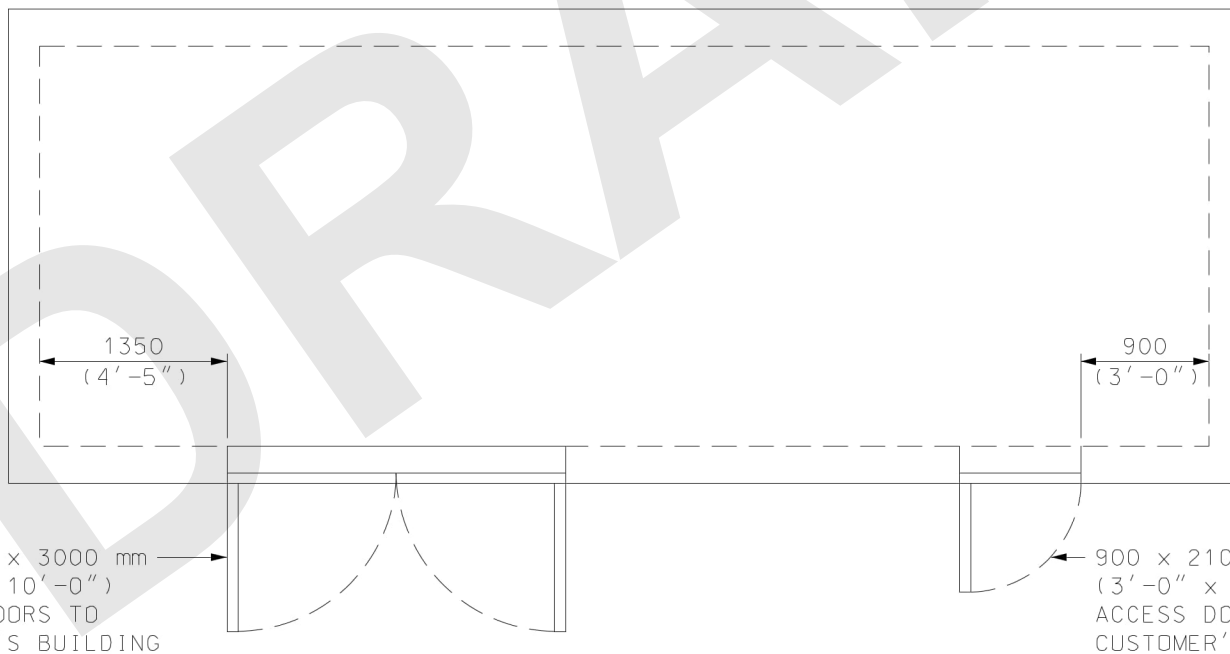

⚠ ABOVE GRADE - WALK-IN VAULT

13-4010 - 13.8 kV RADIAL (MAX. 2500 kVA TRANSFORMER) ELECTRICAL EQUIPMENT LAYOUT
 13-5010 - 13.8 kV NETWORK (MAX. 2000 kVA TRANSFORMERS)
 CIVIL STRUCTURE - 3000 x 8530 x 3660 mm (10'-0" x 28'-0" x 12'-0")

DISTRIBUTION CONSTRUCTION STANDARD
 Civil Construction

CUSTOMER-OWNED STRUCTURES
4.16 kV - 13.8 kV TRANSFORMER VAULTS



Approved By:
 J.D. 2014-02-04

Drafted By:
 K.H.

Designed By:
 J.D.

Original Issue:
 C.P./G.D 2003-11-27

Scale:
 N.T.S.

Rev:
4

31-6080

2/3

© CERTIFIED BY TORONTO HYDRO STANDARD <STANDARDS@TORONTOHYDRO.COM>, THIS DOCUMENT IS FOR USE BY TORONTO HYDRO AND AUTHORIZED PERSONS ONLY AS PER THE TERMS IN TORONTO HYDRO STANDARD 00-0002.

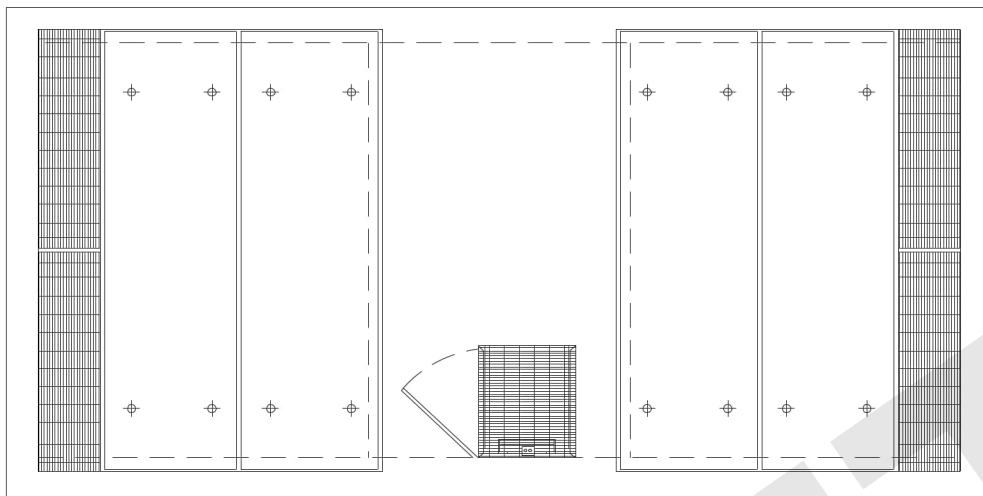

⚠ BELOW GRADE - TOP ENTRY

13-5010 - 13.8 kV NETWORK (MAX. 2000 kVA TRANSFORMERS) ELECTRICAL EQUIPMENT LAYOUT
 31-5180 - MAX. 750 kVA TRANSFORMERS - 2290 x 6700 x 3660 mm (7'-6" x 22'-0" x 12'-0")

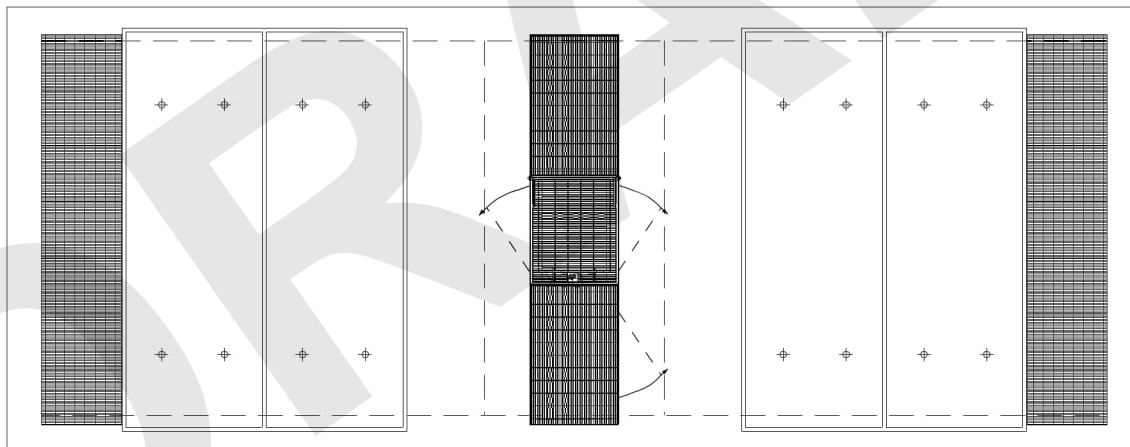

⚠ BELOW GRADE - TOP ENTRY

13-5010 - 13.8 kV NETWORK (MAX. 2000 kVA TRANSFORMERS) ELECTRICAL EQUIPMENT LAYOUT
 31-5130 - MAX. 2000 kVA TRANSFORMERS - 3000 x 8530 x 3660 mm (10'-0" x 28'-0" x 12'-0")

NOTE:

1) THIS DRAWING SHALL BE READ IN CONJUNCTION WITH STD. 31-6000 AND STD. 31-6010.

DISTRIBUTION CONSTRUCTION STANDARD
 Civil Construction

CUSTOMER-OWNED STRUCTURES



4.16 kV - 13.8 kV TRANSFORMER VAULTS



Approved By:
 J. D. 2014-02-04

Drafted By:
 K. H.

Designed By:
 J. D.

Original Issue:
 C. P. / G. D. 2003-11-27

Scale:
 N. T. S.

Rev:
4

31-6080

3/3

© CERTIFIED BY TORONTO HYDRO STANDARD <STANDARDS@TORONTOHYDRO.COM>, THIS DOCUMENT IS FOR USE BY TORONTO HYDRO AND AUTHORIZED PERSONS ONLY AS PER THE TERMS IN TORONTO HYDRO STANDARD 00-0002.

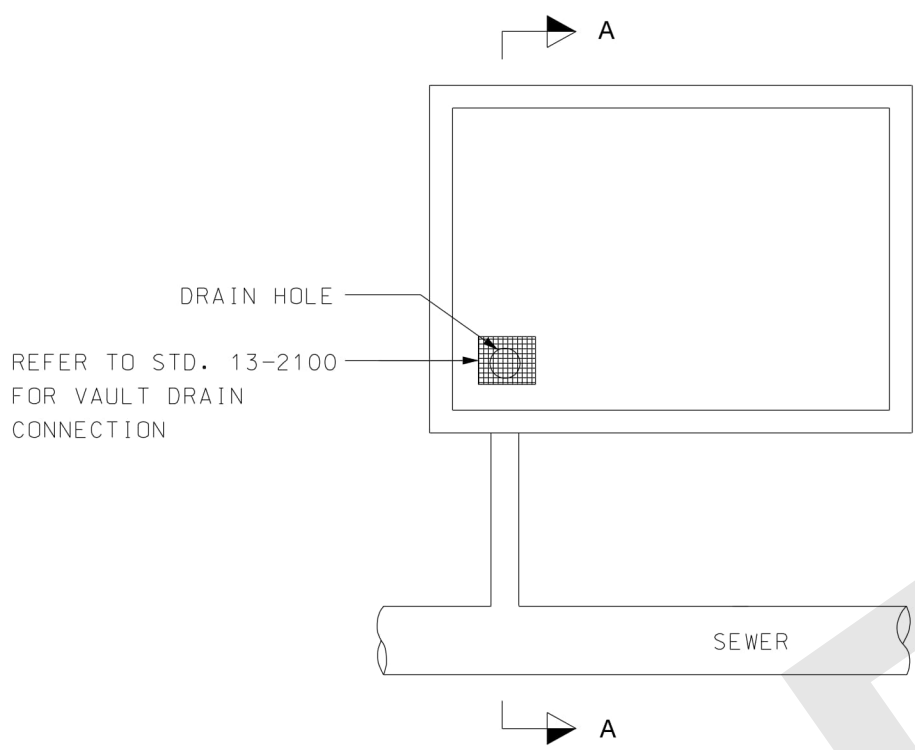

PLAN VIEW
CABLE CHAMBERS AND TRANSFORMER VAULTS
DRAIN CONNECTION TO SEWER

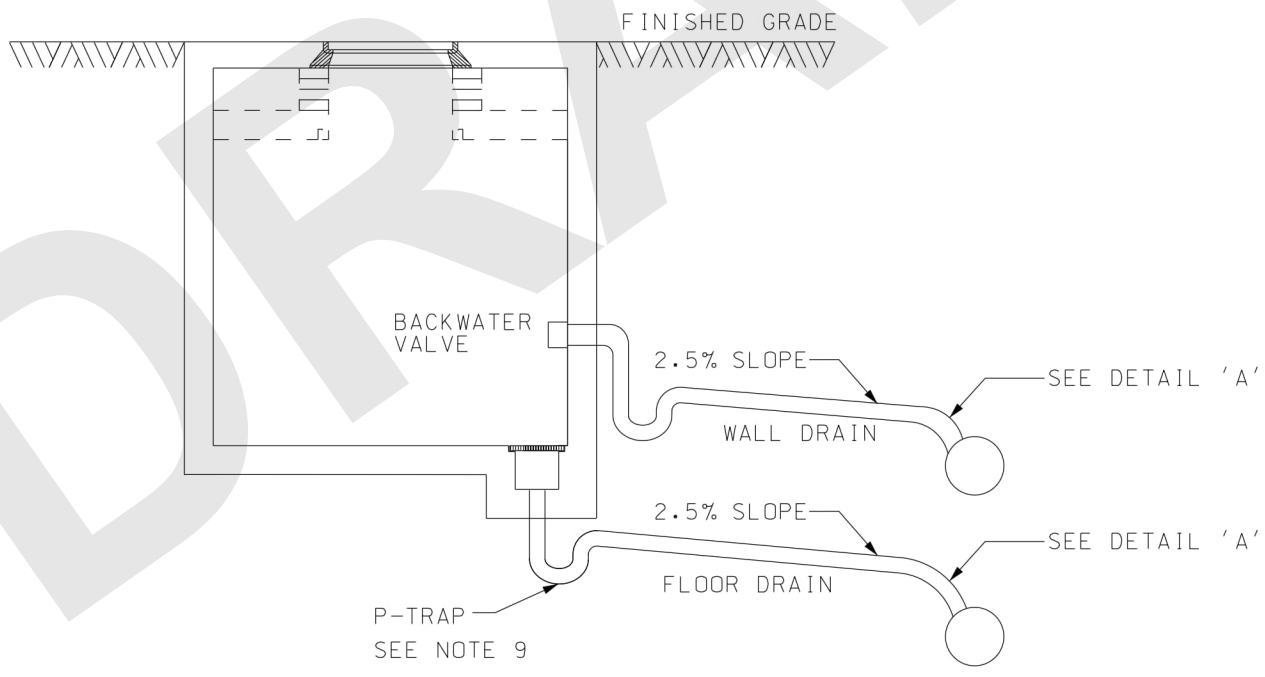

SECTION 'A-A'
ONLY 1 DRAIN SHALL BE INSTALLED

DISTRIBUTION CONSTRUCTION STANDARD Civil Construction		DRAINING STRUCTURES						
	Approved By: J.D. 2018-03-07						Drafted By: B.D.	Designed By: J.D.

© CERTIFIED BY TORONTO HYDRO STANDARD <STANDARDS@TORONTOHYDRO.COM>, THIS DOCUMENT IS FOR USE BY TORONTO HYDRO AND AUTHORIZED PERSONS ONLY AS PER THE TERMS IN TORONTO HYDRO STANDARD 00-0002.

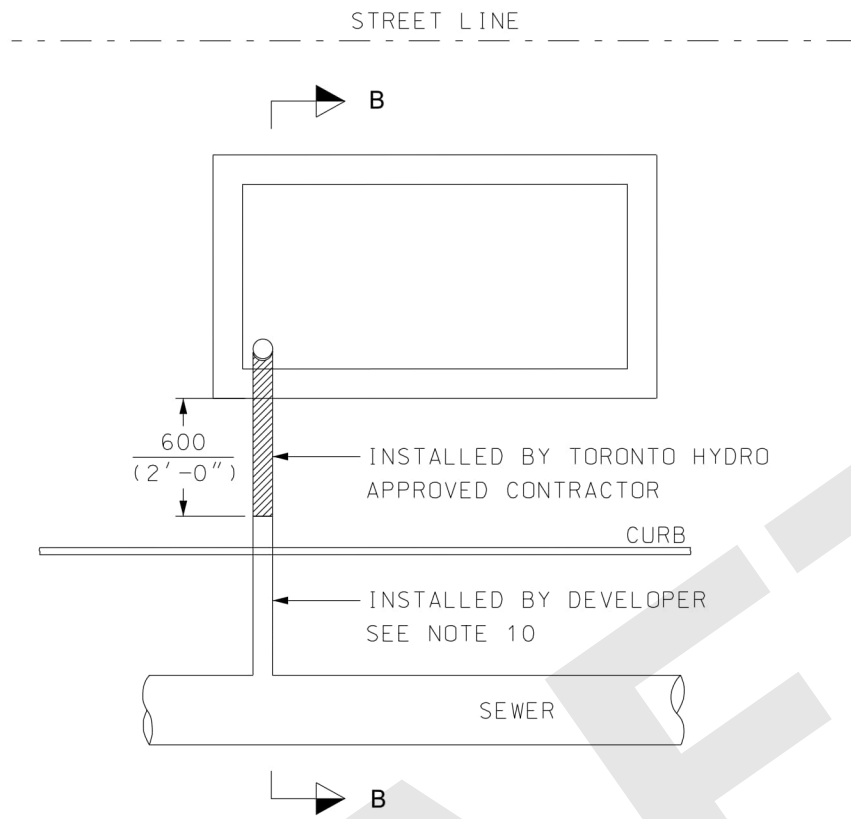

PLAN VIEW

SUBMERSIBLE VAULTS DRAIN CONNECTION TO SEWER

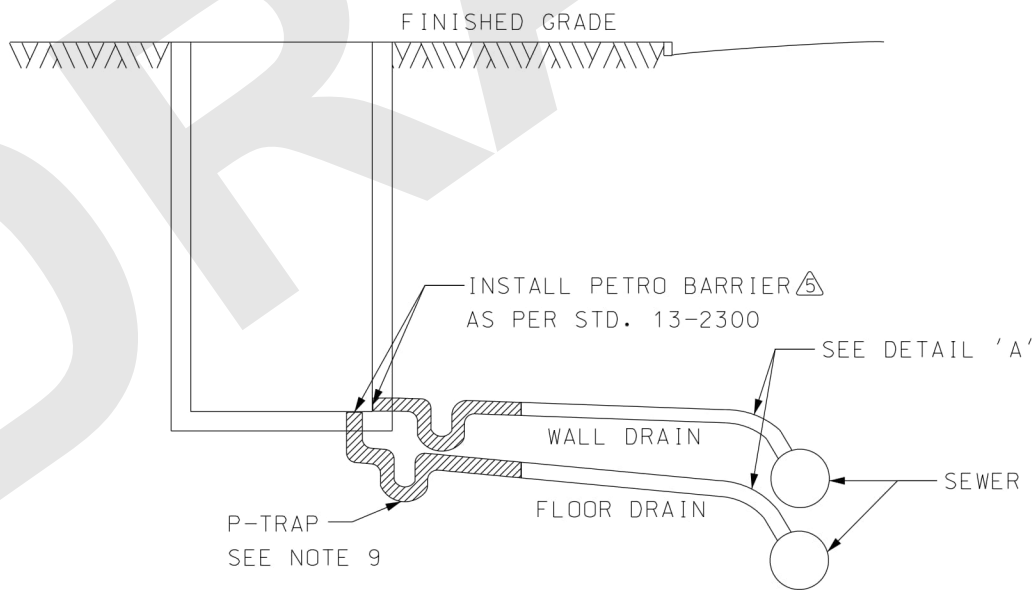

SECTION 'B-B'

ONLY 1 DRAIN SHALL BE INSTALLED

DISTRIBUTION CONSTRUCTION STANDARD
Civil Construction

DRAINING STRUCTURES



Approved By:
J.D. 2018-03-07

Drafted By: B.D. Designed By: J.D.

Original Issue:
G.D. 2007-10-19

Scale:
N.T.S.

Rev: **5**

31-7100

2/5

© CERTIFIED BY TORONTO HYDRO STANDARD <STANDARDS@TORONTOHYDRO.COM>; THIS DOCUMENT IS FOR USE BY TORONTO HYDRO AND AUTHORIZED PERSONS ONLY AS PER THE TERMS IN TORONTO HYDRO STANDARD 00-0002.

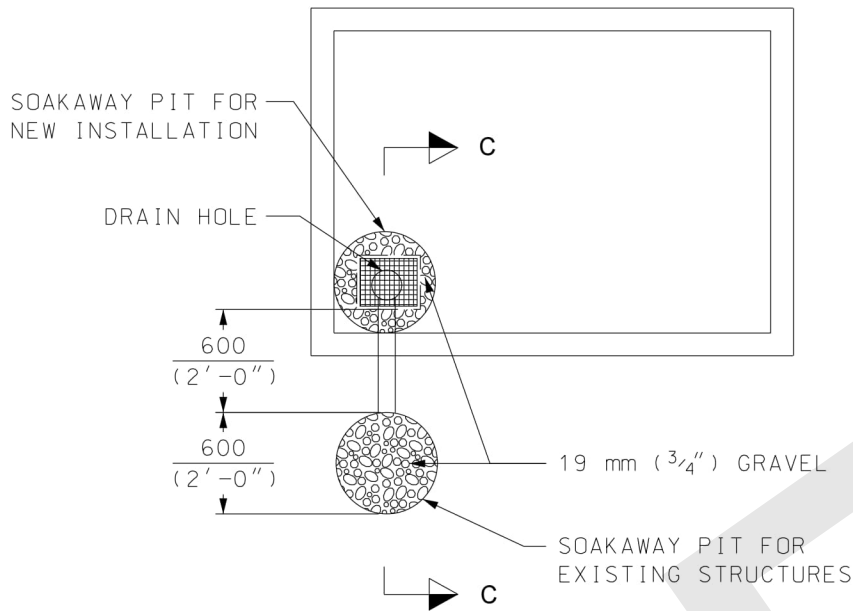

PLAN VIEW

SOAKAWAY PIT CONNECTION FOR CABLE CHAMBERS. ⚠
SPLICE VAULTS AND SUBMERSIBLE VAULTS

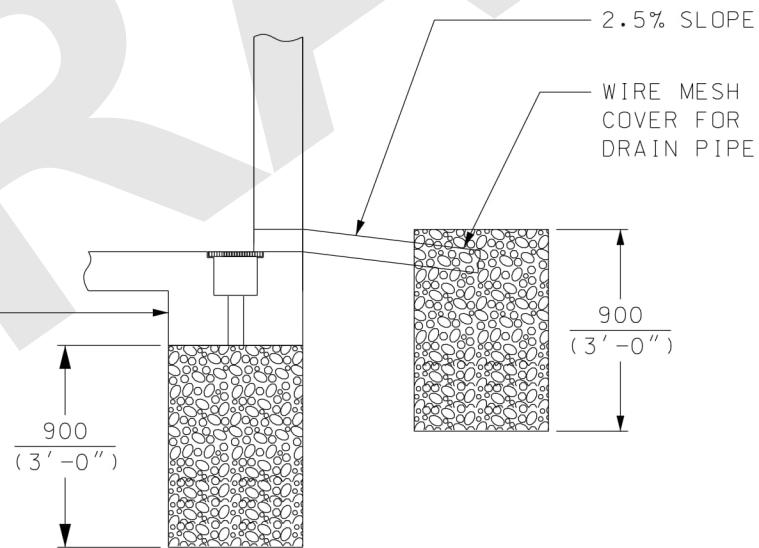

SECTION 'C-C'

ONLY 1 DRAIN SHALL BE INSTALLED

DISTRIBUTION CONSTRUCTION STANDARD
 Civil Construction

DRAINING STRUCTURES



Approved By:
 J.D. 2018-03-07

Drafted By: B.D. Designed By: J.D.

Original Issue:
 G.D. 2007-10-19

Scale:
 N.T.S.

Rev: **5**

31-7100

3/5

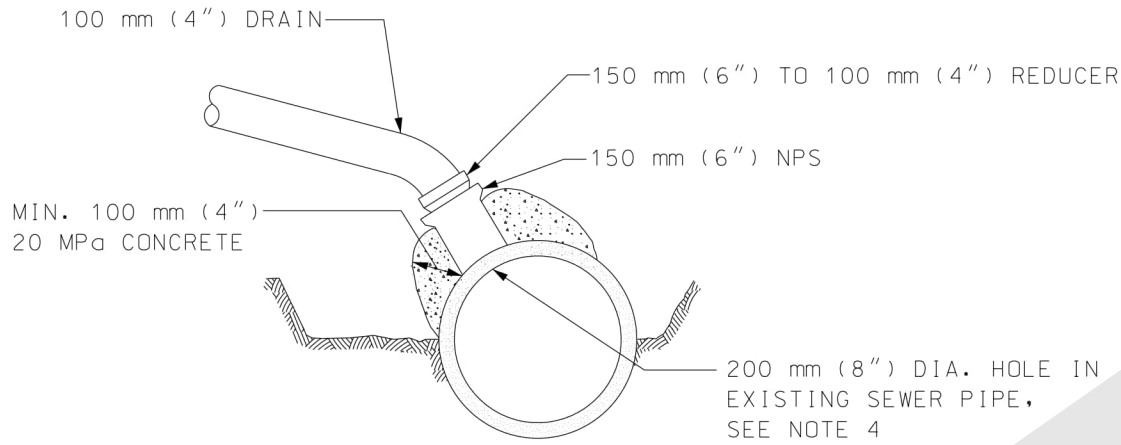

DETAIL 'A'

* DRAIN CONNECTION TO SEWER OPTIONS			
STRUCTURE	OPTION 1	OPTION 2	COMMENTS
CABLE CHAMBERS	STORM SEWER OR COMBINED SEWER WHEN STORM SEWER NOT PRESENT	SANITARY SEWER SEE NOTE 13	OIL CONTAINMENT NOT REQUIRED
SWITCHING VAULTS			
TRANSFORMER VAULTS	STORM SEWER OR COMBINED SEWER WHEN STORM SEWER NOT PRESENT	SANITARY SEWER SEE NOTE 13	OIL CONTAINMENT REQUIRED
SUBMERSIBLE VAULTS			

* SEE NOTE 15



DRAINAGE ORDER OF PRIORITY 1, 2, AND 3				
	CABLE CHAMBER	SWITCH VAULT	SUB VAULT	NETWORK/URD/ CRD VAULT
DRAIN TO SEWER	1	1	1	1
SOAKAWAY PIT (NO SEWER CONNECTION)	2	2	2	-
NO DRAIN PROVISION	3	3	-	-

DISTRIBUTION CONSTRUCTION STANDARD
Civil Construction

DRAINING STRUCTURES



Approved By:
J.D. 2018-03-07

Drafted By: B.D. Designed By: J.D.

Original Issue:
G.D. 2007-10-19

Scale:
N.T.S.

Rev: **5**

31-7100

4/5

NOTES

- 1) DRAIN CONNECTION TO SEWER IS THE PREFERRED OPTION AS PER TABLE SHOWN ABOVE.
- 2) FOR CABLE CHAMBERS, SPLICE VAULTS AND SUBMERSIBLE VAULTS, IF SEWER IS NOT AVAILABLE TO DRAIN, SOAKAWAY PIT SHALL BE USED AS ALTERNATIVE METHOD TO DRAIN. FOR SUBMERSIBLE VAULTS, PETRO BARRIER WILL STILL NEED TO BE INSTALLED, SEE STANDARD 13-2300 FOR DETAILS.
- 3) FOR CABLE CHAMBERS AND SPLICE VAULTS, IF SEWER CONNECTIONS AND SOAKAWAY PITS ARE NOT FEASIBLE, STRUCTURES SHALL BE CONSTRUCTED WITHOUT DRAINAGE PROVISION.
- 4) SEWER CONNECTIONS FROM TORONTO HYDRO STRUCTURE TO CITY SEWERS SHALL BE 150 mm (6") NPS IN SIZE WITH A 150 (6") X 100 mm (4") REDUCER CONNECTION TO 100 mm (4") DRAIN. THE SEWER CONNECTIONS SHALL BE DRILLED OR CORED, NOT MANUALLY BROKEN WITH HAMMER AND CHISEL. SEWER CONNECTIONS SHALL NOT BE MADE DIRECTLY UNDERNEATH ANY DUCT RUN. NO HORIZONTAL BENDS IN THE DRAIN LINE ARE ALLOWED.
- 5) ALL DRAIN LENGTHS, BENDS AND COUPLINGS SHALL BE 100 mm (4") DIA. METER PVC.
- 6) IN A SUBMERSIBLE VAULT, FLOOR DRAIN CONNECTION IS PREFERRED. IF THE SEWER IS AT A HIGHER ELEVATION, DRAIN CAN BE INSTALLED IN WALL. DRAIN SHALL BE LOCATED IN THE SECONDARY CABLES COMPARTMENT ONLY. SEE NOTES 10 AND 11.
- 7) ENTIRE DRAIN LENGTH SHALL BE INSTALLED ON BEDDING OF 75 mm (3") OF GRANULAR 'A' MATERIAL.
- 8) ALL CONNECTIONS TO SEWERS SHALL BE INSTALLED TO CITY OF TORONTO STANDARDS AND APPROVED ON SITE BY THE AUTHORIZED REPRESENTATIVE OF THE CITY OF TORONTO.
- 9) P-TRAPS WITH 90° ELBOWS ARE REQUIRED FOR EVERY DRAIN TO SEWER CONNECTION AND SHALL BE AT LEAST 100 mm (4") NPS, PVC.
- 10) IN NEW DEVELOPMENTS, DEVELOPER SHALL INSTALL 100 mm (4") DRAIN PIPE FROM SEWER AND TO TERMINATE PIPE 600 mm (2'-0") FROM SUBMERSIBLE VAULT WALL AND TO PLACE A CAP AND MARKER POST FOR FUTURE CONNECTION.
- 11) IN NEW DEVELOPMENTS, DEVELOPER SHALL INSTALL THE SEWER PIPE AT A REQUIRED DEPTH SO THAT THE PROPOSED DRAIN FROM TORONTO HYDRO STRUCTURE TO THE SEWER WILL HAVE A 2.5% SLOPE.
- 12) 100 mm (4") PVC BACKWATER OR CHECK VALVES SHALL BE INSTALLED IN ALL VAULTS AND CABLE CHAMBERS WHENEVER THE WALL DRAINPIPE CONNECTION IS AT OR ABOVE THE CHAMBER FLOOR. THE VALVES SHALL BE POSITIONED VERTICALLY ABOVE THE CHAMBER OR VAULT SUMP PIT IN THE WALL ON THE SIDE OF THE CONNECTING DRAIN TO THE CITY SEWER.
- 13) THE VALVE SHALL BE A MINIMUM OF 450 mm (1'-6") AND A MAXIMUM OF 1500 mm (4'-11") ABOVE THE FLOOR, BUT NEVER HIGHER THAN THE INVERT LEVEL OF THE LOWEST DUCT ENTERING THE VAULT OR CHAMBER. THE VALVE SHALL BE IN GOOD WORKING CONDITION WHEN INSTALLED.
- 14) APPLICATIONS FOR DRAIN CONNECTION TO SEWER (OPTION 1 OR 2) SHALL BE APPROVED BY CITY OF TORONTO ENVIRONMENTAL MONITORING AND PROTECTION (EM&P) DESIGNATED STAFF. EM&P REVIEW WILL INCUR EXTRA TIME FOR APPROVAL BASED ON THE COMPLEXITY AND SIZE OF THE PROPOSED INFRASTRUCTURE.
- 15) CONNECTION TO ANY SEWER SYSTEM:
 - THE JOINING OF ANY DUCT BANK, WHICH DRAIN TO A VAULT, WILL BE EXECUTED IN ACCORDANCE TO THE MANUFACTURER'S RECOMENDATIONS TO ACHIEVE WATER TIGHTNESS USING MECHANICAL COUPLINGS, GLUED CONNECTIONS, OR OTHER BEST AVAILABLE TECHNOLOGIES.

DISTRIBUTION CONSTRUCTION STANDARD
Civil Construction

DRAINING STRUCTURES



Approved By:
J.D. 2018-03-07

Drafted By: B.D. Designed By: J.D.

Original Issue:
G.D. 2007-10-19

Scale:
N.T.S.

Rev:

5

31-7100

5/5

© CERTIFIED BY TORONTO HYDRO STANDARD <STANDARDS@TORONTOHYDRO.COM>; THIS DOCUMENT IS FOR USE BY TORONTO HYDRO AND AUTHORIZED PERSONS ONLY AS PER THE TERMS IN TORONTO HYDRO STANDARD 00-0002.

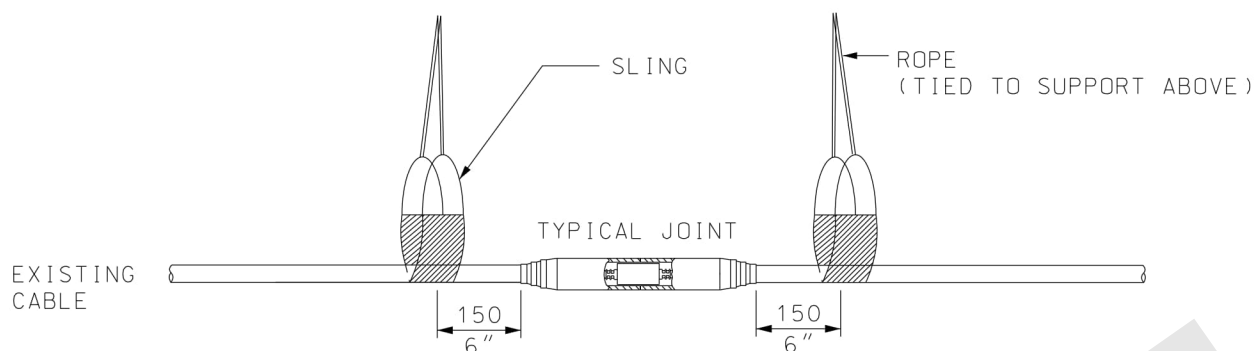

△ CABLES < 750 V OR FIBRE COMMUNICATION

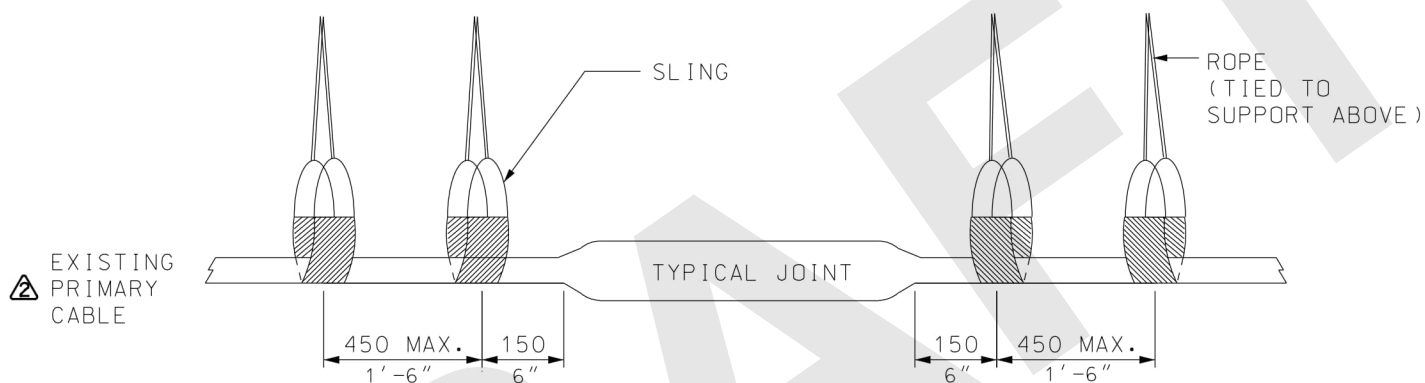

CABLES > 750 V

BOM LEGEND	
A	CABLE SLINGS TO SUPPORT CABLES >750 V
B	CABLE SLINGS TO SUPPORT CABLES <750 V OR FIBRE COMMUNICATION

BILL OF MATERIALS FOR 31-7400				
ITEM NO.	DESCRIPTION	ITEM I.D.	QTY	
			A	B
1	CABLE SLING 6" X 18" REINFORCED WITH 1" NYLON STRAP	9662943	4	2

NOTES: △

- 1) ENSURE CABLE, JOINTS AND GROUNDING INTEGRITY PRIOR AND AFTER INSTALLATION OF TEMPORARY CABLE SUPPORTS. PCB SAMPLING IS REQUIRED PRIOR TO COMMENCING THE WORK IF CONTAMINATION IS SUSPECTED.
- 2) SEPARATE SUPPORT SLINGS ARE REQUIRED WHEN SUPPORTING CABLES > 750V OR < 750V OR FIBRE COMMUNICATION WITHIN THE STRUCTURE UNTIL PERMANENT SUPPORTS (CABLE RACKING) ARE INSTALLED.
- 3) AT NO TIME DIFFERENT CABLE TYPES SHALL BE SUPPORTED ON SAME SUPPORT SLING.
- 4) CONTRACTOR IS RESPONSIBLE TO VERIFY IF THIRD PARTY COMMUNICATION CABLES WITHIN THE STRUCTURE REQUIRE SPECIFIC OR ADDITIONAL SUPPORT REQUIREMENTS.
- 5) AT ALL TIMES WHEN INSTALLING THE TEMPORARY CABLE SUPPORT SLINGS, THE EXISTING CABLE'S ROUTE AND JOINT ELEVATION SHALL BE MAINTAINED TO AVOID ADDING UNNECESSARY MECHANICAL STRESSES.
- 6) REFER TO STD. 16-1280 FOR CABLE TESTING IF CABLES ARE TO REMAIN IN PLACE AND NOT REPLACED.

DISTRIBUTION CONSTRUCTION STANDARD
Civil Construction

TEMPORARY SUPPORT OF CABLES △
IN REBUILD STRUCTURES (CABLE CHAMBERS, VAULTS)



Approved By:

Drafted By:
J. D.

Designed By:
B. D.

Original Issue:
J. D. 2013-05-31

Scale:
N. T. S.

Rev:

2

31-7400

1/1

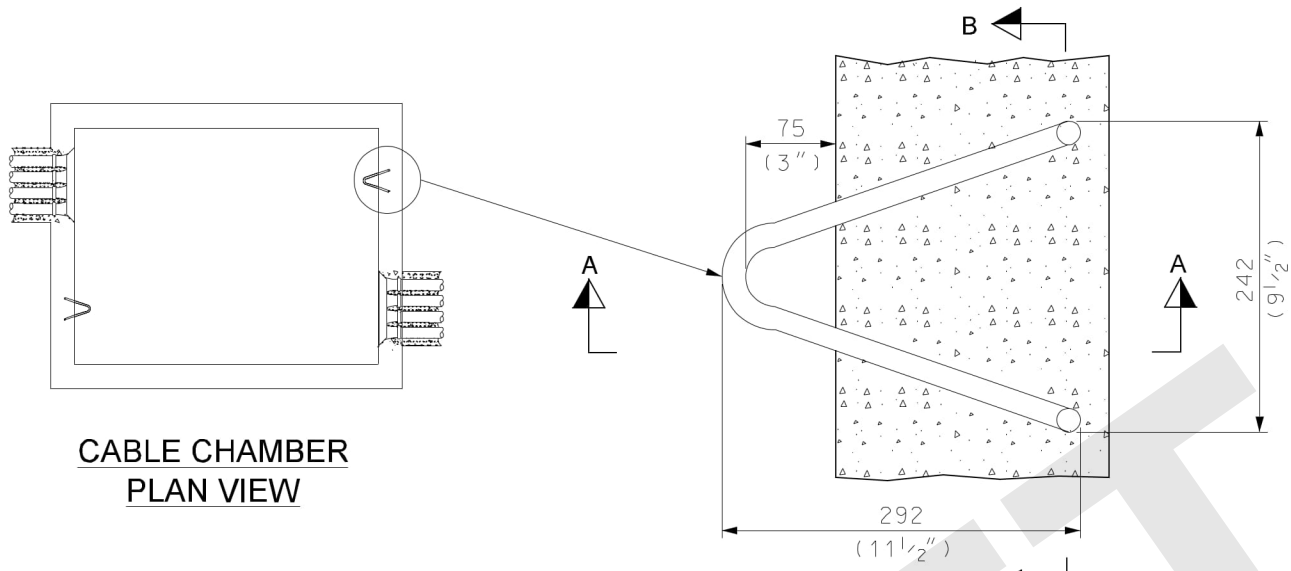

**CABLE CHAMBER
PLAN VIEW**

PLAN VIEW

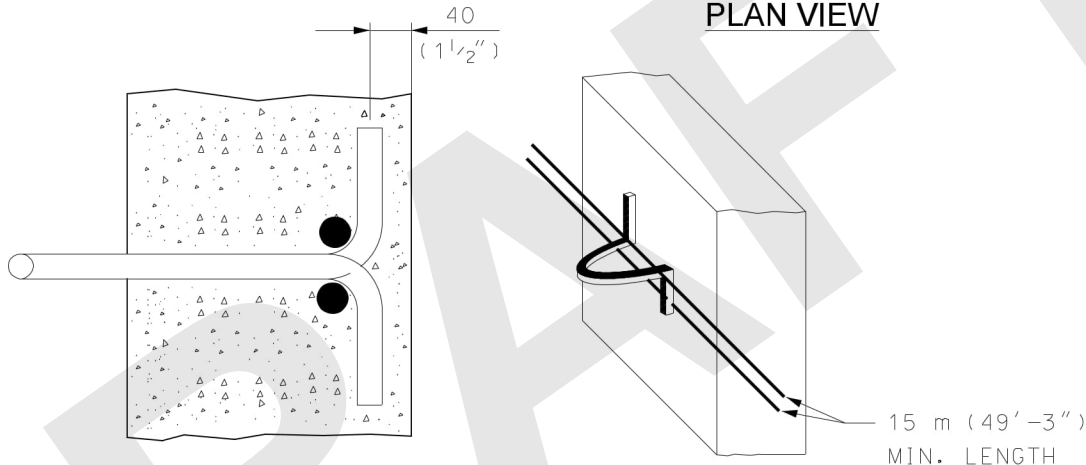

SECTION "A-A"

SECTION "B-B"

15 m (49' -3")
MIN. LENGTH

NOTES:

- 1) MAXIMUM PULLING FORCE - 40 kN
- 2) MATERIAL IS MILD STEEL, 20 mm (3/4") DIAMETER DEVELOPED LENGTH 775 mm (2'-7").
- 3) ALL PARTS TO BE GALVANIZED IN ACCORDANCE WITH LATEST CSA STD. G-164, F_u=400 MPa MIN., F_y=250 MPa MIN.

ID #3530112

DISTRIBUTION CONSTRUCTION STANDARD Civil Construction		MATERIAL FABRICATION CABLE PULLING LOOP FOR POURED & PRECAST CONCRETE WALLS				
	Approved By: J.D. 2012-11-05	Original Issue: J.D. 2000-12-20		Scale: N.T.S.	Rev: 2	31-8210
	Drafted By: D.L.	Designed By: J.D.				

© CERTIFIED BY TORONTO HYDRO STANDARD - STANDARDS@TORONTOHYDRO.COM. THIS DOCUMENT IS FOR USE BY TORONTO HYDRO AND AUTHORIZED PERSONS ONLY AS PER THE TERMS IN TORONTO HYDRO STANDARD 00-0002.

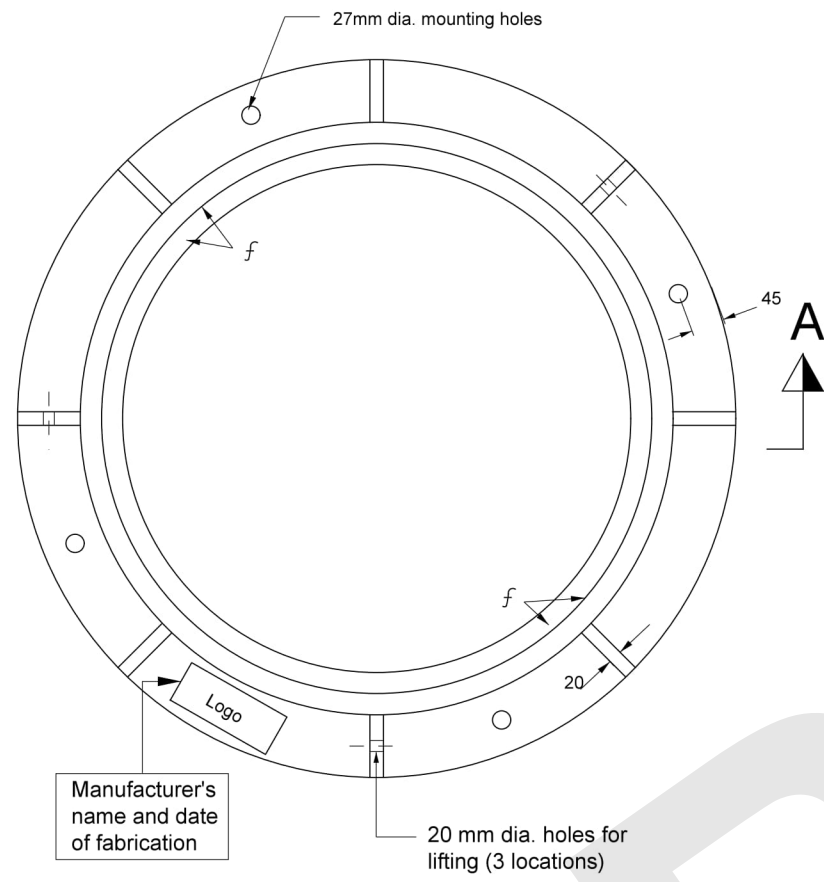

CABLE CHAMBER FRAME

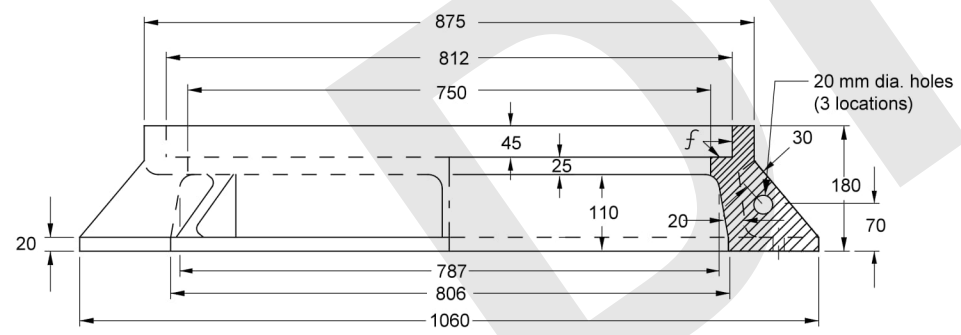

SECTION A-A

Material	ID #
180mm Frame With Cover	9662442
180mm Frame	3530116
Cover	3530505

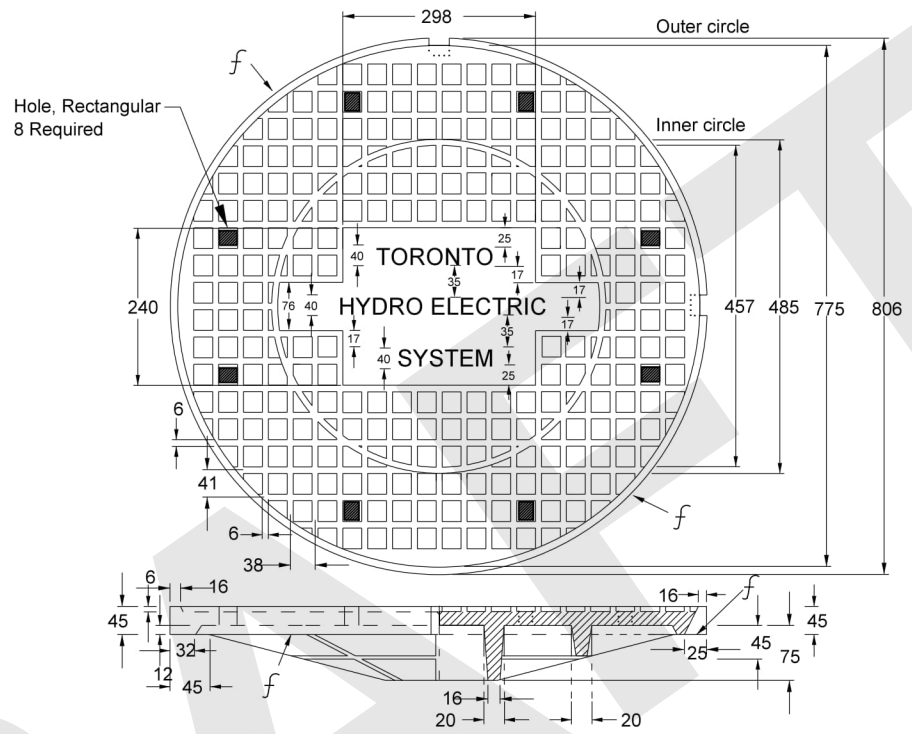

CABLE CHAMBER COVER

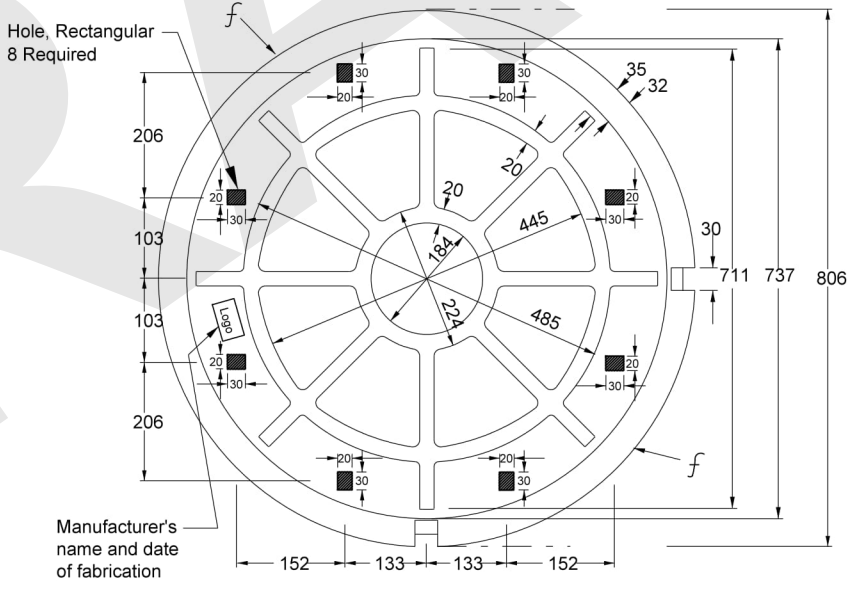

Manufacturer's name and date of fabrication

Notes:

1. All dimensions are in millimeters unless noted otherwise.
2. Machine where marked *f*.
3. To be fabricated as per Toronto Hydro pattern.
4. Strength & acceptance shall conform to the latest CSA standard C83.43.
5. Design load is in accordance with canadian highway bridge design code CAN/CSA-S6-06, CL-625 ONT live loading
6. Grey cast iron, class 200MPa, Min., mass=150kg.
7. Workmanship & finish to conform to ASTM standard A48. Paint both sides black with asphalt or pitch.
8. Cable chamber cover design meets non slip requirements as outlined in the Standard Practice for Safe Walking Surfaces document "ASTM F1637-09" and also the "City of Toronto Accessibility Design Guidelines" document dated 2004.

DISTRIBUTION CONSTRUCTION STANDARD
Civil Construction - Material Fabrication

Approved By: J. D. 2011-04-29
Drafted By: L. L. Designed By: G. D.

CABLE CHAMBER: 180mm FRAME & COVER
UNDERGROUND CONSTRUCTION MATERIALS

Original Issue: G.D. 2004-03-31	Scale: N.T.S.	Rev: 4	31-8250	1/1
---------------------------------	---------------	--------	---------	-----

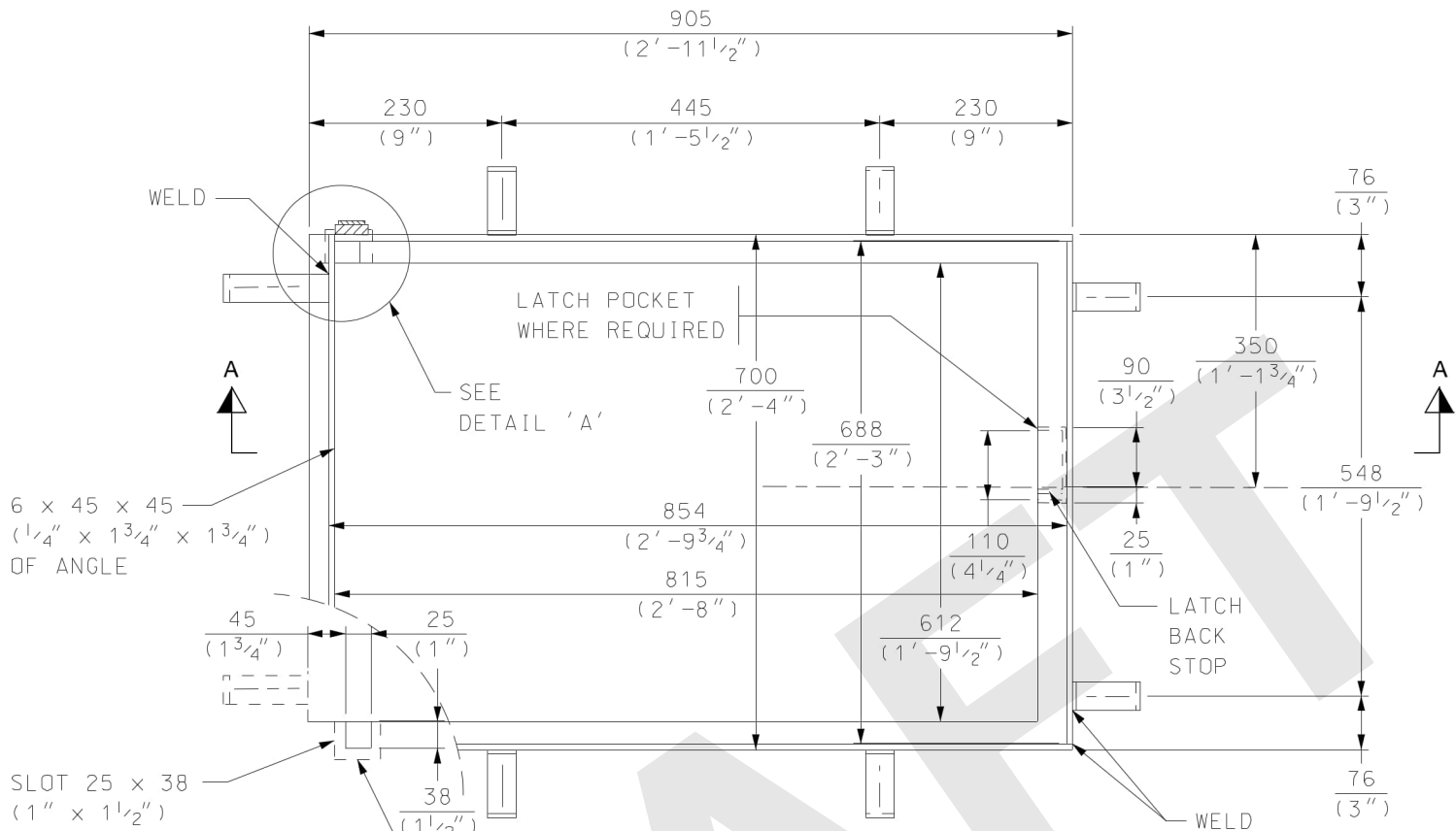

PLAN VIEW

6 x 45 x 45 (1/4" x 1 3/4" x 1 3/4") OF ANGLE

WELD

LATCH POCKET WHERE REQUIRED

SEE DETAIL 'A'

700 (2'-4")

688 (2'-3")

90 (3 1/2")

350 (1'-1 3/4")

548 (1'-9 1/2")

854 (2'-9 3/4")

815 (2'-8")

110 (4 1/4")

25 (1")

LATCH BACK STOP

76 (3")

45 (1 3/4")

25 (1")

38 (1 1/2")

WELD

1.6 mm (1/16") BLACK SHEET IRON, 50 mm (2") SQ. SPOT WELDED TO BOTTOM OF 6 x 45 x 45 (1/4" x 1 3/4" x 1 3/4") ANGLE

SEE DETAIL 'B'

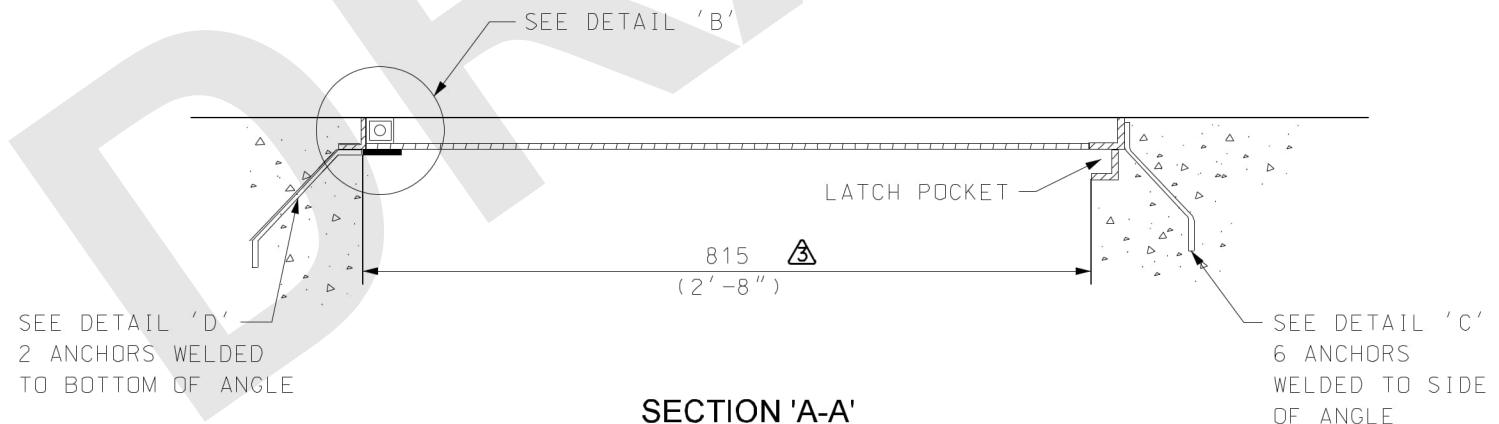

SECTION 'A-A'

SEE DETAIL 'D'

2 ANCHORS WELDED TO BOTTOM OF ANGLE

LATCH POCKET

815 (2'-8")

SEE DETAIL 'C'

6 ANCHORS WELDED TO SIDE OF ANGLE

ID # 3530022

NOTE:
1) FRAME SHALL BE GALVANIZED IN ACCORDANCE WITH THE LATEST C.S.A. STANDARD G-164.

DISTRIBUTION CONSTRUCTION STANDARD Civil Construction		LADDERWAY GRID FRAME FOR TRANSFORMER VAULT					
Approved By: J. D. 2015-09-21		Original Issue: G. D. / L. G. 2002-11-15		Scale: N. T. S.	Rev: 3	31-8320	1/2
Drafted By: K. K.		Designed By: J. D.					

© CERTIFIED BY TORONTO HYDRO STANDARD <STANDARDS@TORONTOHYDRO.COM>; THIS DOCUMENT IS FOR USE BY TORONTO HYDRO AND AUTHORIZED PERSONS ONLY AS PER THE TERMS IN TORONTO HYDRO STANDARD 00-0002.

2 mm ($\frac{1}{16}$ ") STEEL,
25 mm (1") SQ.
WELDED OVER HOLE \triangle

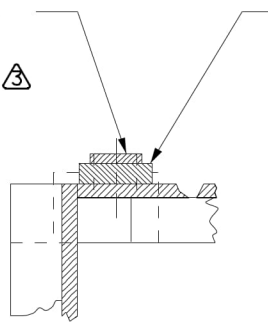

DETAIL 'A'

13 x 38 x 35 F. I.
($\frac{1}{2}$ " x $1\frac{1}{2}$ " x $1\frac{1}{2}$ ")
WELDED ON ALL
4 SIDES TO
6 x 45 x 45
($\frac{1}{4}$ " x $1\frac{3}{4}$ " x $1\frac{3}{4}$ ")
ANGLE

22 mm ($\frac{7}{8}$ ") HOLE
DRILLED THROUGH
2 THICKNESSES \triangle

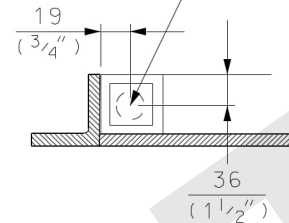

DETAIL 'B'

**DETAILS OF HOUSING
FOR HINGE PIN**

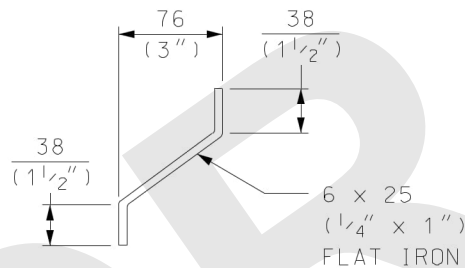

DETAIL 'C'
6 REQUIRED

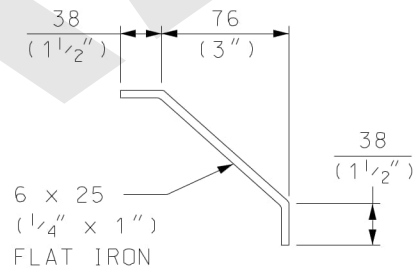

DETAIL 'D'
2 REQUIRED

DETAIL OF ANCHORS

DISTRIBUTION CONSTRUCTION STANDARD
Civil Construction



Approved By:
J. D. 2015-09-21

Drafted By:
K. K.

Designed By:
J. D.

Original Issue:
G. D. / L. G. 2002-11-15

Scale:
N. T. S.

Rev: **3**

31-8320

2/2

**LADDERWAY GRID FRAME
FOR TRANSFORMER VAULT**

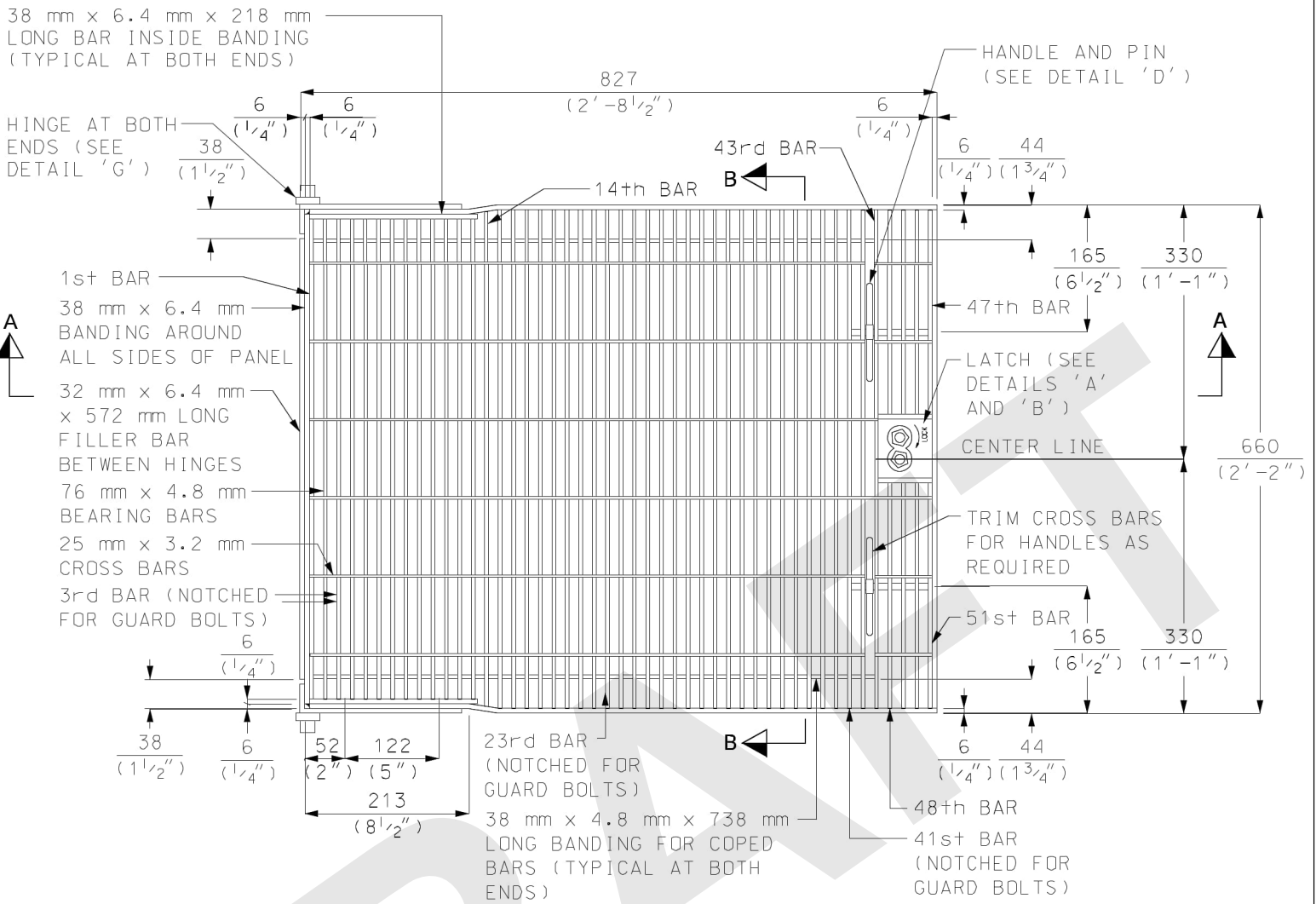

PANEL DETAIL PLAN

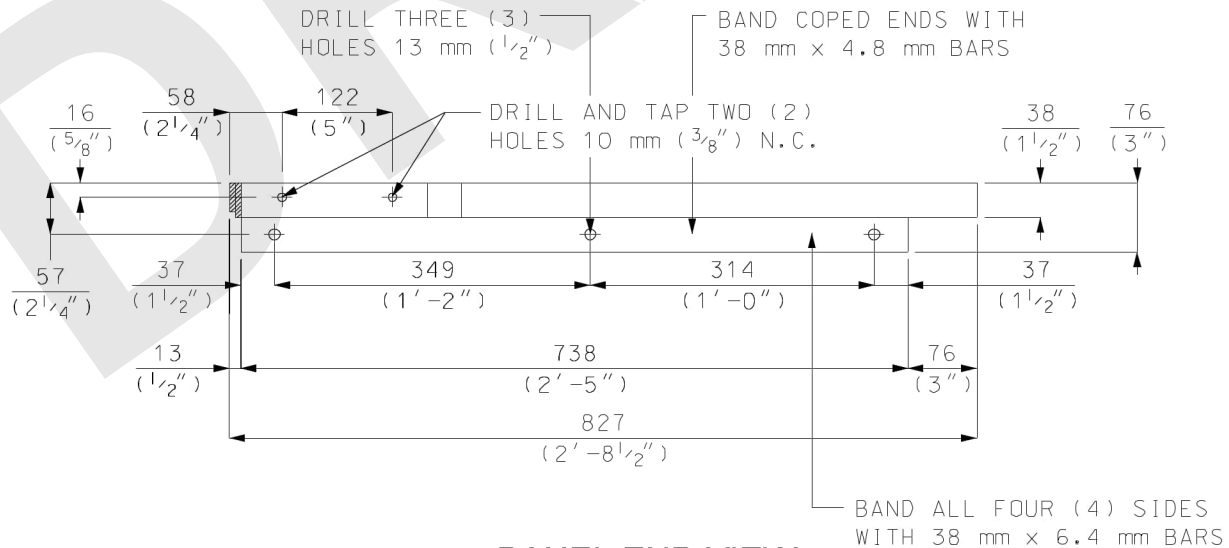

PANEL END VIEW

DISTRIBUTION CONSTRUCTION STANDARD
Civil Construction

ALUMINUM LADDERWAY GRID



Approved By:
J.D. 2014-03-19

Drafted By:
S.A.K.

Designed By:
J.D.

Original Issue:
G.D./C.P. 2002-11-15

Scale:
N.T.S.

Rev:
4

31-8330

1/4

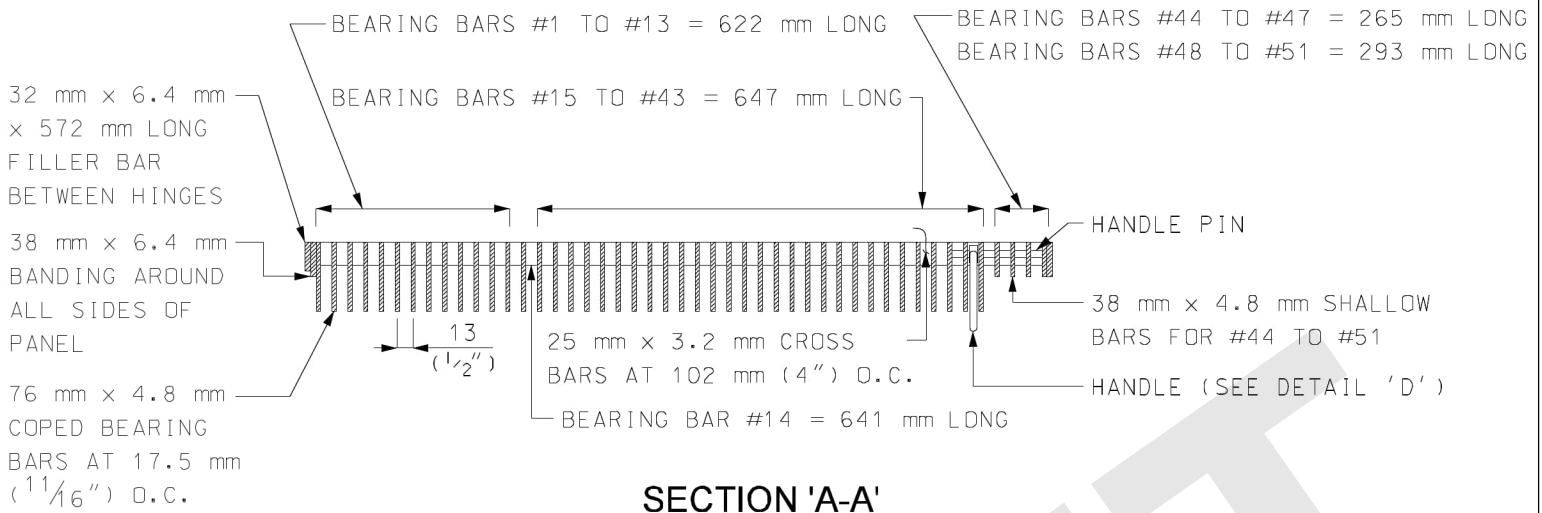

SECTION 'A-A'

BEARING BARS TO HAVE A SERRATED SURFACE (4 SERRATIONS IN EACH 102 mm LENGTH)

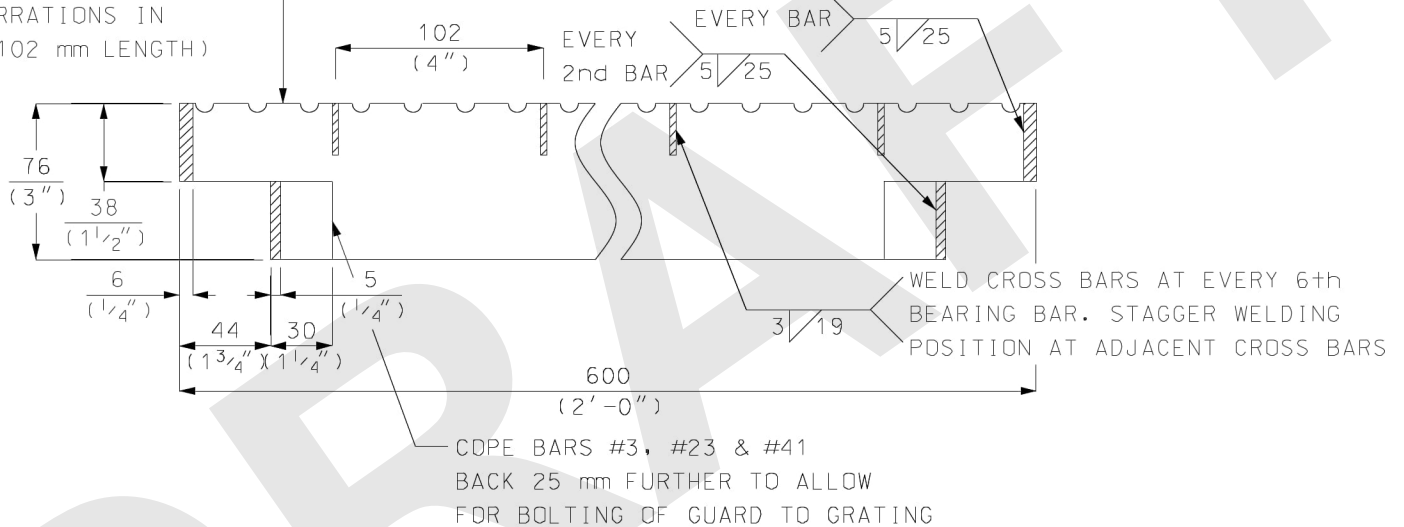

SECTION 'B-B'

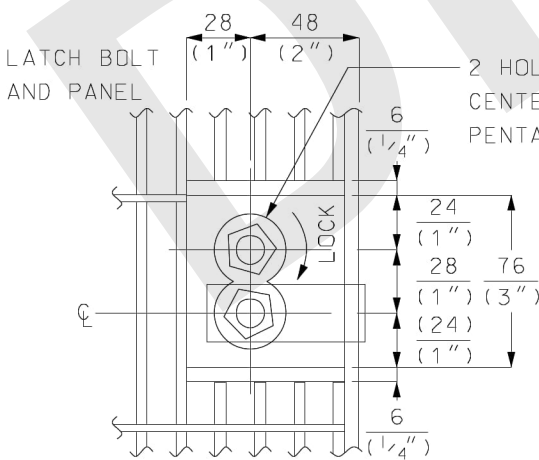

DETAIL 'A'

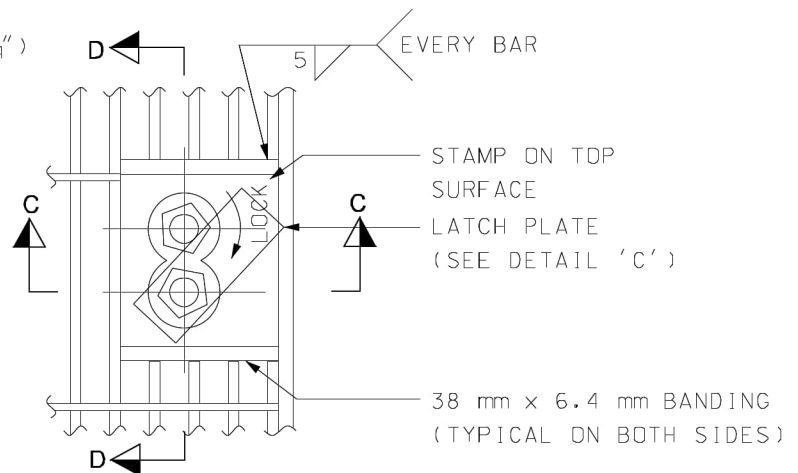

DETAIL 'B'

DISTRIBUTION CONSTRUCTION STANDARD
Civil Construction

ALUMINUM LADDERWAY GRID



Approved By:
J.D. 2014-03-19

Drafted By:
S.A.K.

Designed By:
J.D.

Original Issue:
G.D./C.P. 2002-11-15

Scale:
N.T.S.

Rev:
4

31-8330

2/4

© CERTIFIED BY TORONTO HYDRO STANDARD <STANDARDS@TORONTOHYDRO.COM>, THIS DOCUMENT IS FOR USE BY TORONTO HYDRO AND AUTHORIZED PERSONS ONLY AS PER THE TERMS IN TORONTO HYDRO STANDARD 00-0002.

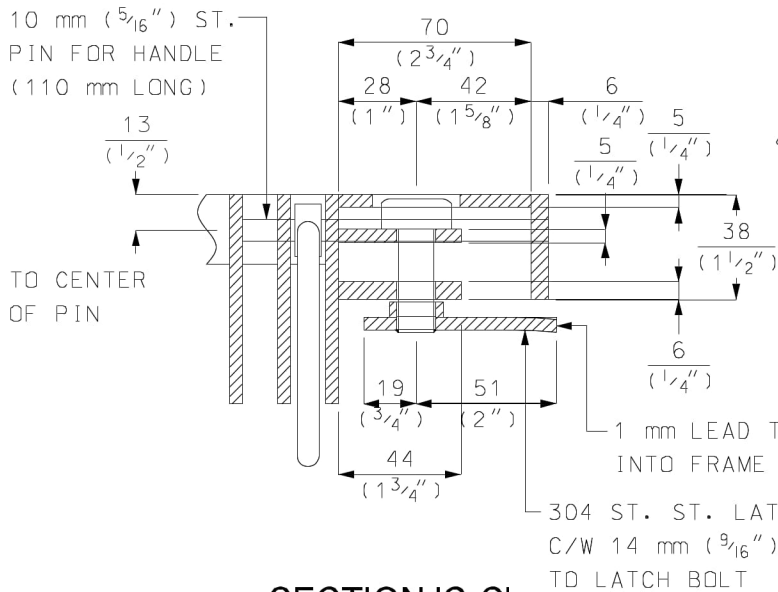

SECTION 'C-C'

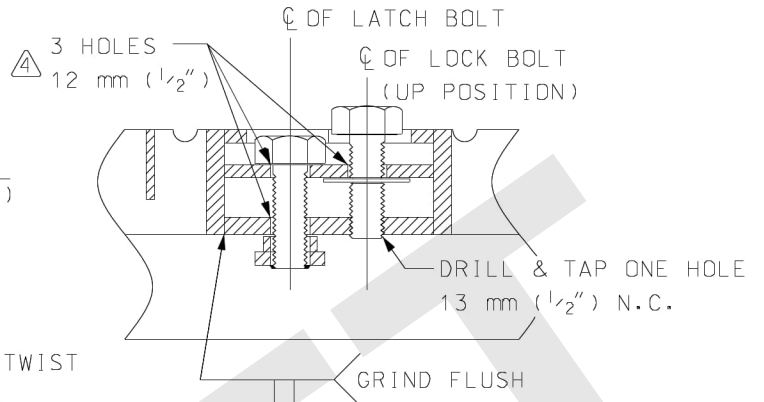

SECTION 'D-D'

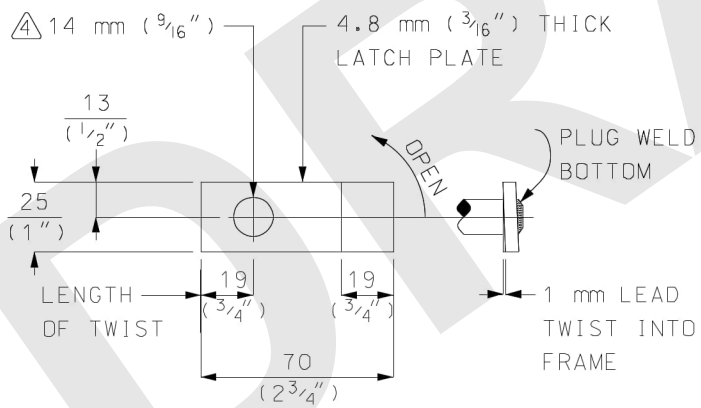

DETAIL 'C'

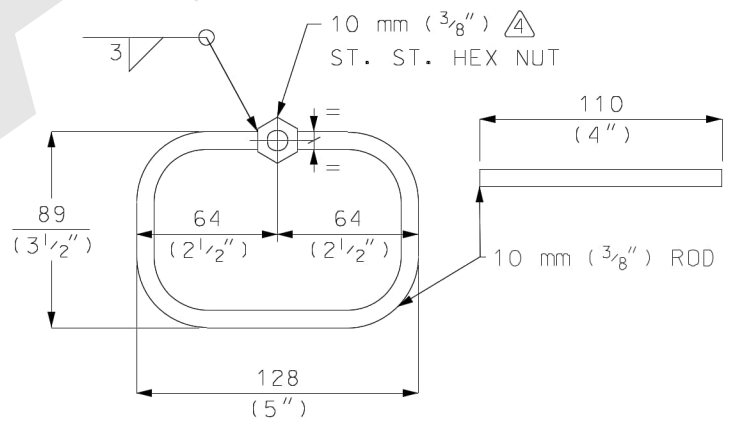

DETAIL 'D'

DISTRIBUTION CONSTRUCTION STANDARD
Civil Construction

ALUMINUM LADDERWAY GRID



Approved By:
J.D. 2014-03-19
Drafted By:
S.A.K.
Designed By:
J.D.

Original Issue:
G.D./C.P. 2002-11-15

Scale:
N.T.S.

Rev:
4

31-8330

3/4

TOP VIEW

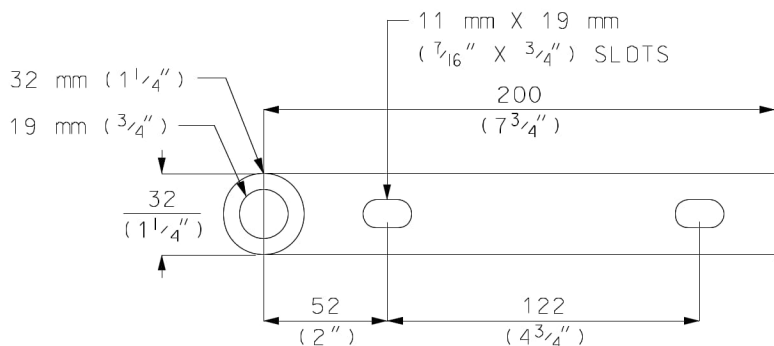

DETAIL 'E'

TOP VIEW

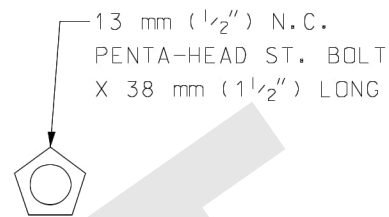

DETAIL 'F'

FRONT VIEW

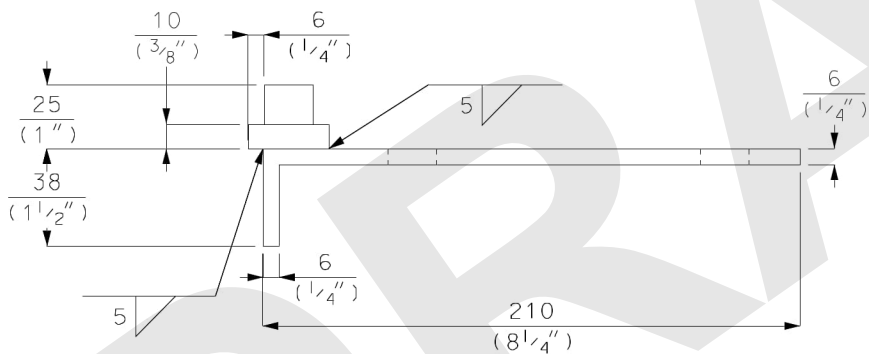

DETAIL 'G'

FRONT VIEW

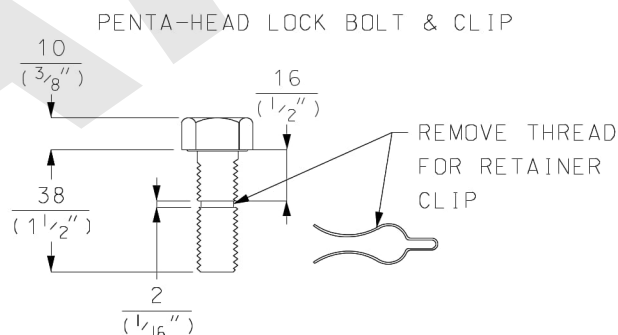

DETAIL 'H'

NOTES:

- 1) BEARING BAR MATERIAL SHALL BE 6061-T6 ALUMINUM. CROSS BARS SHALL BE NOTCHED AND HYDRAULICALLY PRESSED INTO DOVETAILED SLOTS IN BEARING BARS TO PROVIDE A POSITIVE WEDGED CONNECTION.
- 2) DESIGN SHALL MEET CANADIAN HIGHWAY BRIDGE DESIGN CODE CAN/CSA-S6-06, CL-625-ONT LIVE LOADING.
- 3) HINGE BOLTS, PENTA-HEAD LATCH BOLTS, LATCH PLATE, AND HANDLES SHALL BE 304 MILL FINISH STAINLESS STEEL.
- 4) ALUMINUM GRID FINISH SHALL BE CLEAN ANODIZED TO AA-C22A31 STANDARD.
- 5) ALL STAINLESS STEEL ITEMS SHALL BE INSTALLED AFTER ANODIZING.
- 6) REFER TO STD. 31-8340 FOR ALUMINUM LADDERWAY GRATING GUARD.
- 7) DESIGNED ACCORDING TO STANDARD PRACTICE FOR SAFE WALKING SURFACES, F1637-09 AND CITY OF TORONTO ACCESSIBILITY DESIGN GUIDELINES, LATEST REVISION.

DISTRIBUTION CONSTRUCTION STANDARD
Civil Construction

ALUMINUM LADDERWAY GRID



Approved By:
J.D. 2014-03-19

Drafted By:
S.A.K.

Designed By:
J.D.

Original Issue:
G.D./C.P. 2002-11-15

Scale:
N.T.S.

Rev:
4

31-8330

4/4

© CERTIFIED BY TORONTO HYDRO STANDARD <STANDARDS@TORONTOHYDRO.COM>, THIS DOCUMENT IS FOR USE BY TORONTO HYDRO AND AUTHORIZED PERSONS ONLY AS PER THE TERMS IN TORONTO HYDRO STANDARD 00-0002.

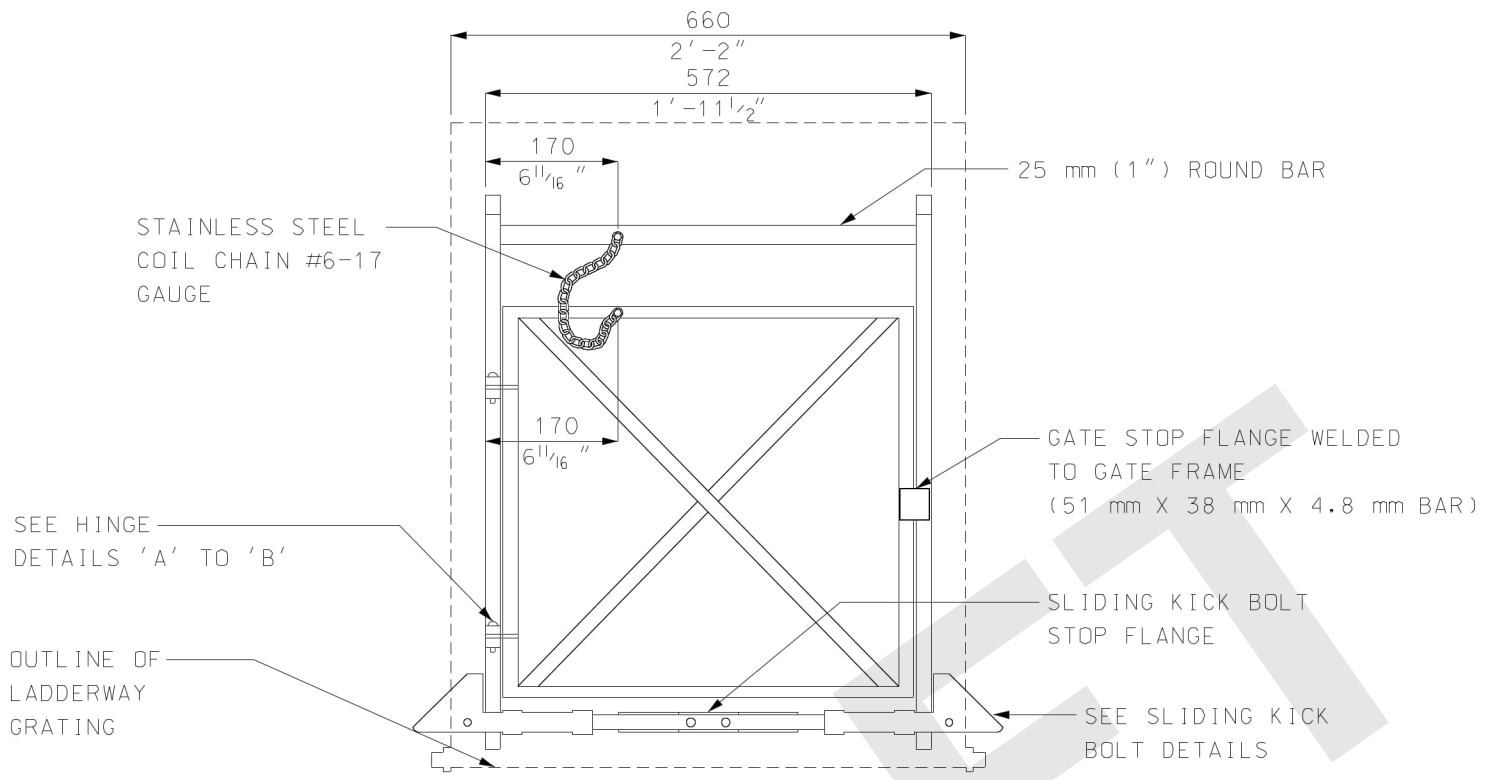

GUARD FRONT VIEW ⚠

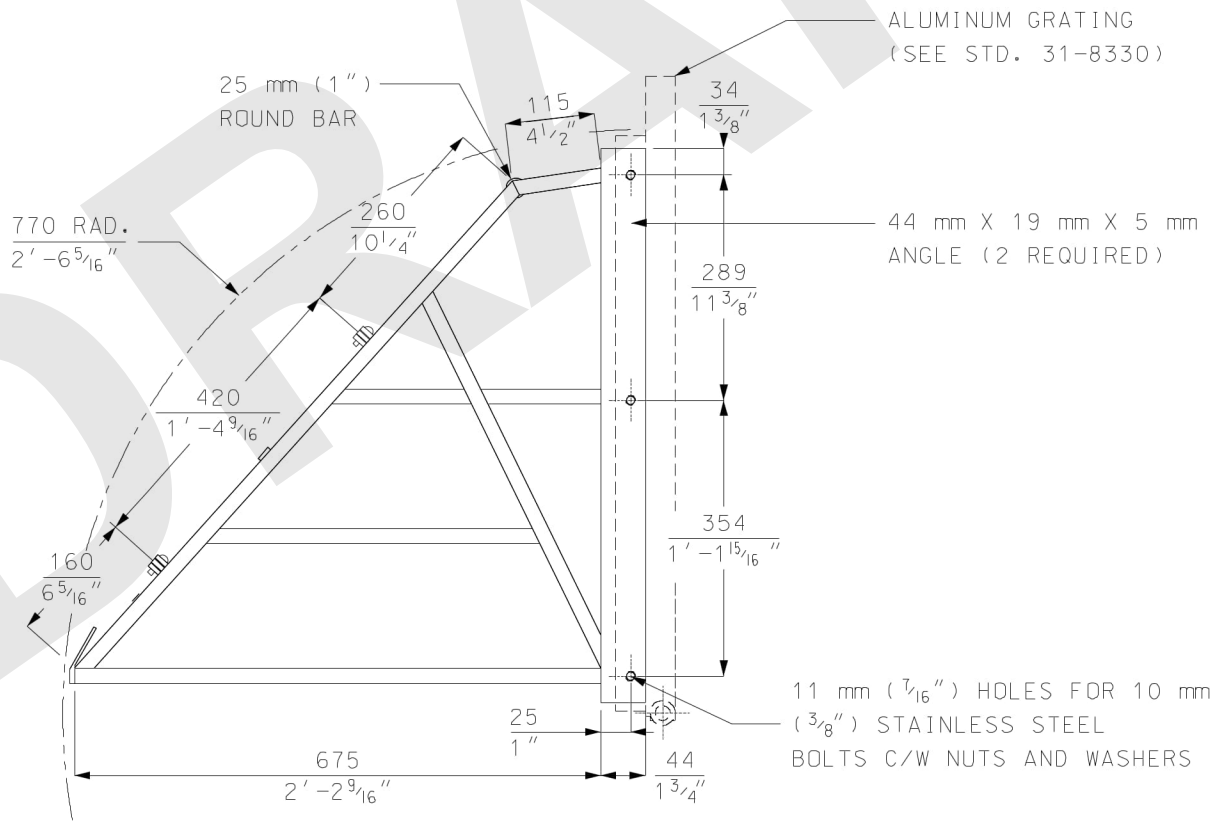

GUARD SIDE VIEW ⚠

DISTRIBUTION CONSTRUCTION STANDARD
Civil Construction

STEEL LADDERWAY GRATING GUARD



Approved By:
B.D. 2020-05-15

Drafted By:
A.M.E.

Designed By:
B.D.

Original Issue:
G.D./C.P. 2002-11-15

Scale:
N.T.S.

Rev:
6

31-8340

1/3

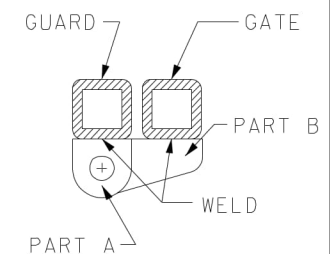
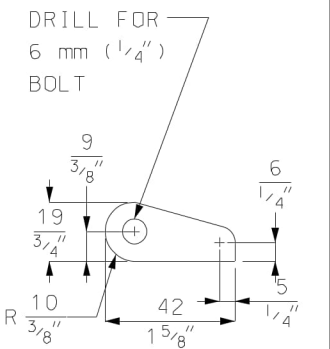
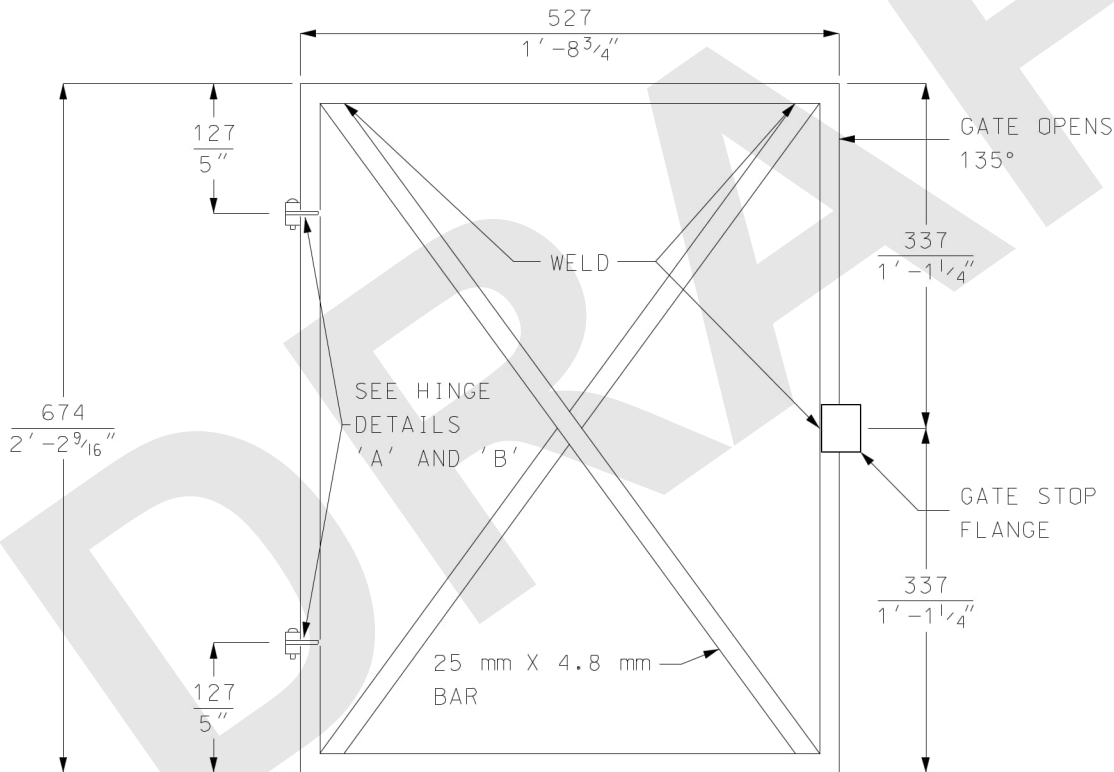
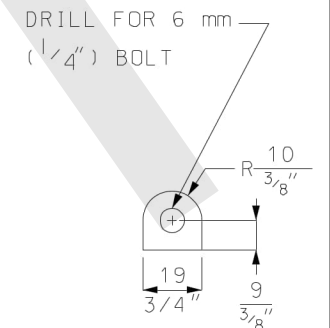
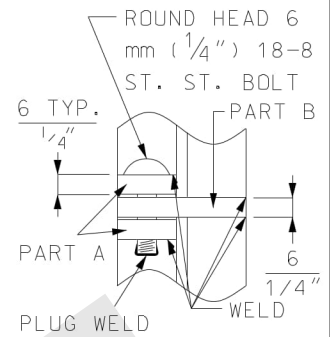
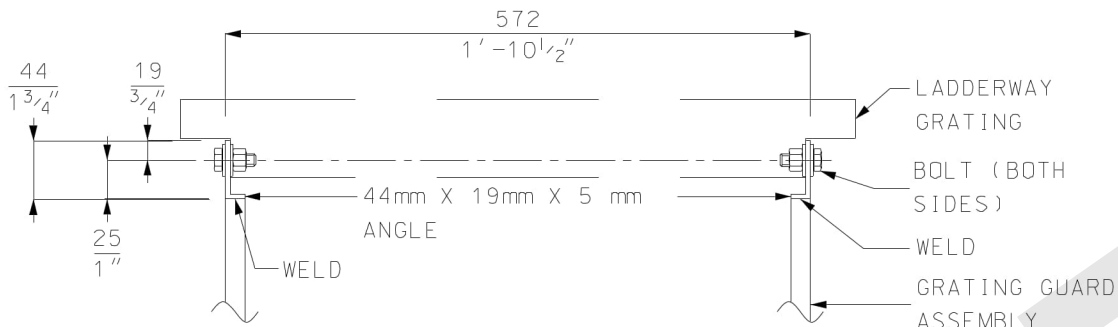

DISTRIBUTION CONSTRUCTION STANDARD
Civil Construction

STEEL LADDERWAY GRATING GUARD



Approved By:
B.D. 2020-05-15

Drafted By: A.M.E.
Designed By: B.D.

Original Issue:
G.D./C.P. 2002-11-15

Scale:
N.T.S.

Rev: **6**

31-8340

2/3



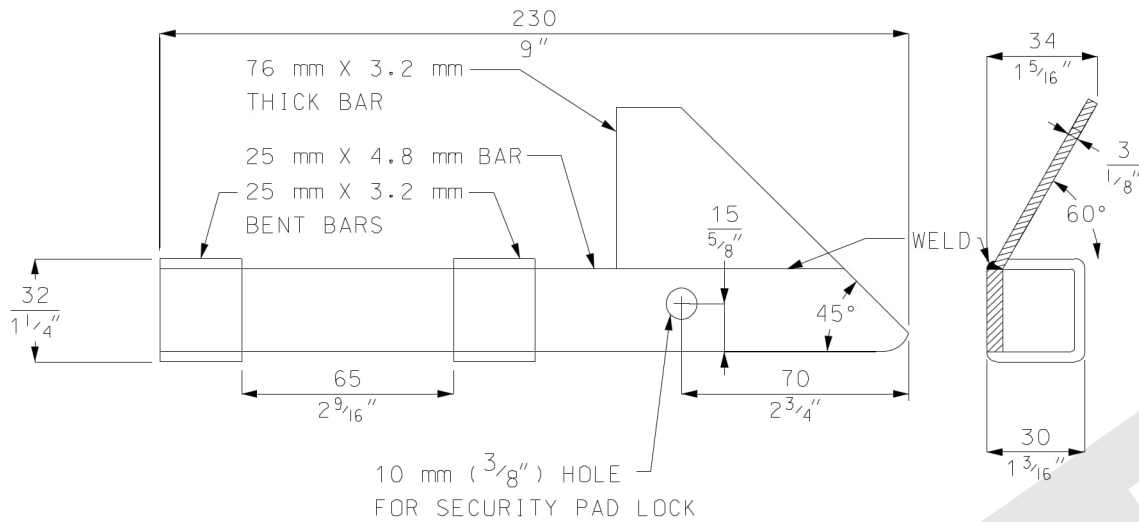

ELEVATION

SECTION

SLIDING KICK BOLT

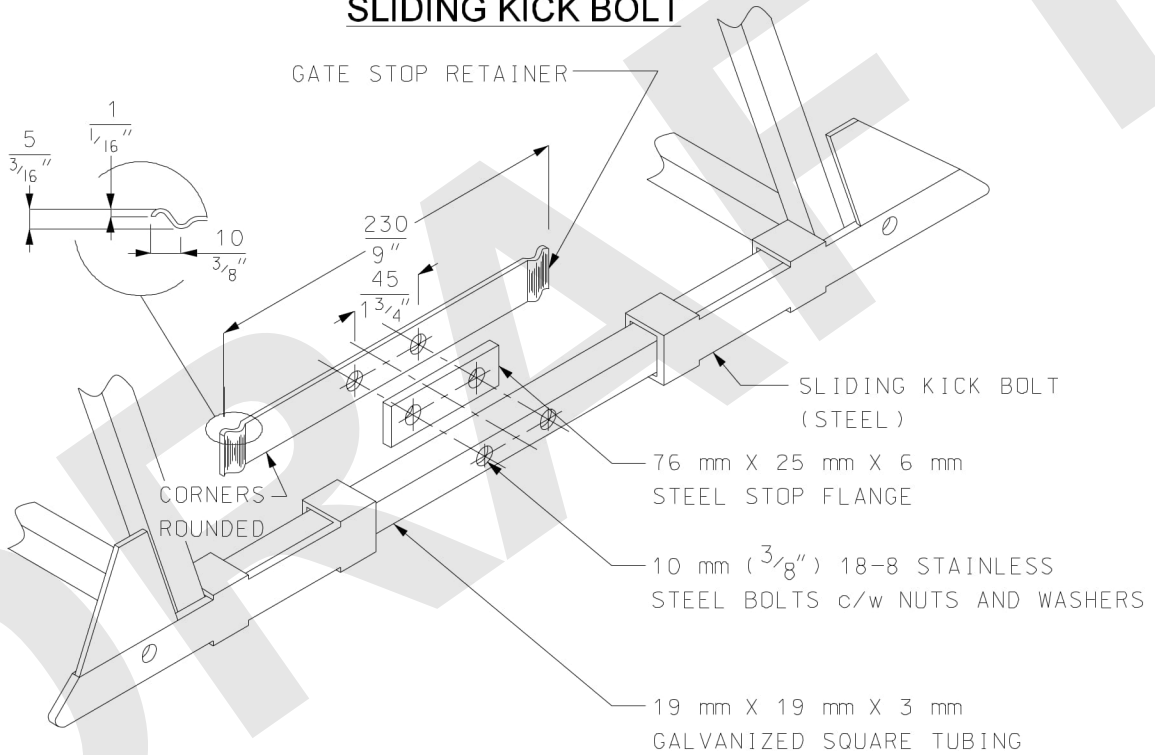

SLIDING KICK BOLT ASSEMBLY

NOTES:

- 1) GUARD AND GATE TO BE FABRICATED OF 19 mm X 19 mm X 3.2 mm GALVANIZED CARBON STEEL SQUARE TUBING.
- 2) WELD ALL JOINTS.
- 3) WHERE POSSIBLE, DRILL/PUNCH ALL HOLES, WELD ALL HINGES AND GATE STOP FLANGE PRIOR TO GALVANIZING.
- 4) ETCH SURFACE AND APPLY "TIGER DRYLAC COATING" IN "SAFETY ORANGE GL/SM" TO GUARD AND GATE.
- 5) LADDERWAY GRATING GUARD TO BE ORDERED IN COMBINATION WITH ALUMINUM GRATING. LADDERWAY GRATING KIT ITEM ID# 9663631.

DISTRIBUTION CONSTRUCTION STANDARD
Civil Construction

STEEL LADDERWAY GRATING GUARD



Approved By:
B.D. 2020-05-15

Drafted By:
A.M.E.

Designed By:
B.D.

Original Issue:
G.D./C.P. 2002-11-15

Scale:
N.T.S.

Rev:
6

31-8340

3/3



© CERTIFIED BY TORONTO HYDRO STANDARD <STANDARDS@TORONTOHYDRO.COM>, THIS DOCUMENT IS FOR USE BY TORONTO HYDRO AND AUTHORIZED PERSONS ONLY AS PER THE TERMS IN TORONTO HYDRO STANDARD 00-0002.

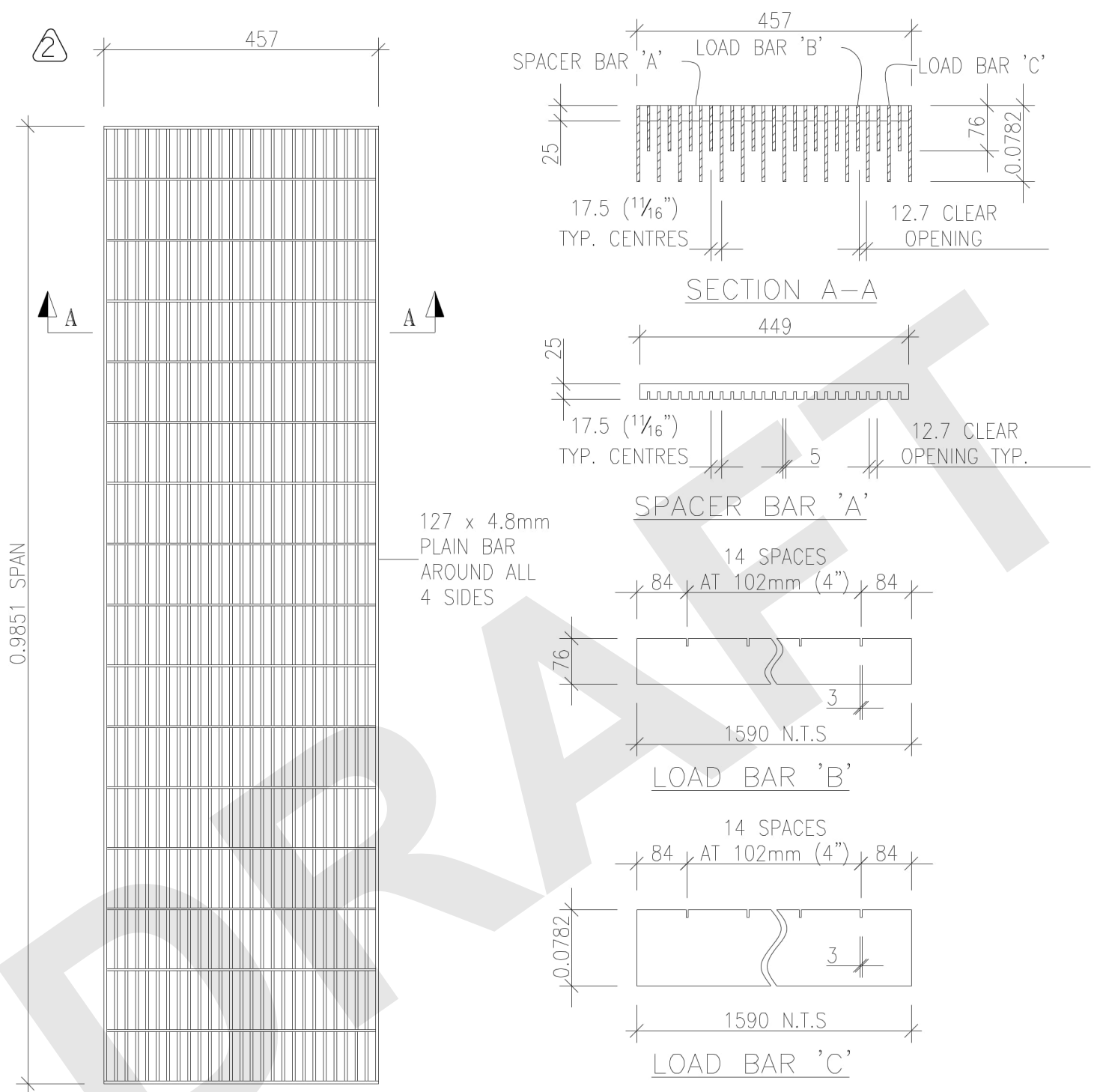

PANEL DETAIL PLAN
ITEM I.D. #9663696

Notes:

1. All dimensions are in millimeters unless noted otherwise.
2. Grid to be galvanized in accordance with latest CSA G-164 standard.
3. Spacer Bars: To be raised 1mm tack weld joints.
4. Load Bars 'B': Weld on one side only at each end.
5. Load Bars 'C': Deep weld at each location.
6. Maximum opening of 13mm between load bars.

BILL OF MATERIAL		
DESCRIPTION	QTY.	LENGTH
127 X 4.8mm	2	459
127 X 4.8mm	2	1590
S.B. 'A' 25 X 3.2mm	15	449
L.B. 'B' 76 X 4.8mm	13	1590
L.B. 'C' 127 X 4.8mm	12	1590
WEIGHT 172KG (380LBS)		

DISTRIBUTION CONSTRUCTION STANDARD
Civil Construction - Material Fabrication

VAULT EXHAUST VENT GRID:
1600 x 457 x 127mm

	Approved By: J.D. 2011-10-11		Original Issue: G.D. C.P. 2002-11-25	Scale: N.T.S.	Rev: 2	31- 8350	1/1
	Drafted By: S.P.	Designed By: J.D.					

© CERTIFIED BY TORONTO HYDRO STANDARD <STANDARDS@TORONTOHYDRO.COM>, THIS DOCUMENT IS FOR USE BY TORONTO HYDRO AND AUTHORIZED PERSONS ONLY AS PER THE TERMS IN TORONTO HYDRO STANDARD 00-0002.

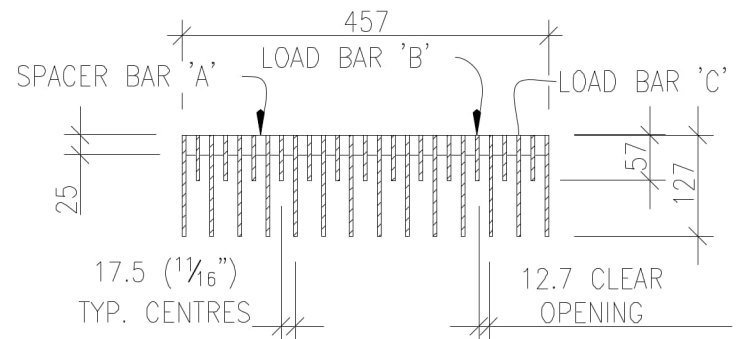
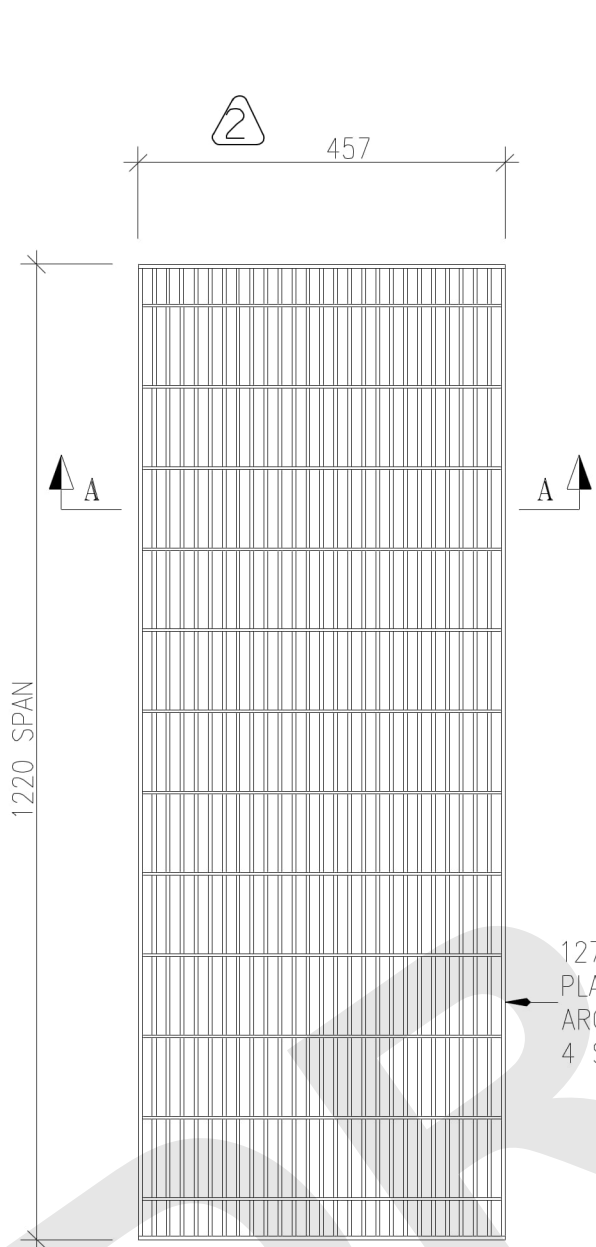

SECTION A-A

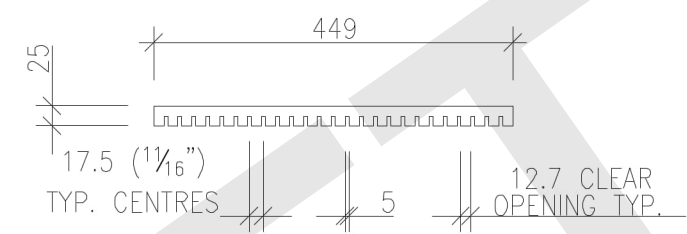

SPACER BAR 'A'

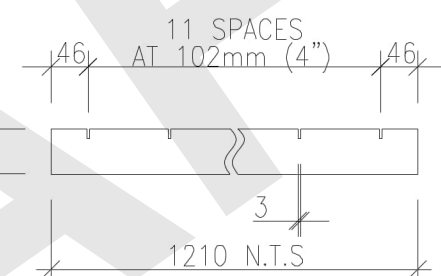

LOAD BAR 'B'

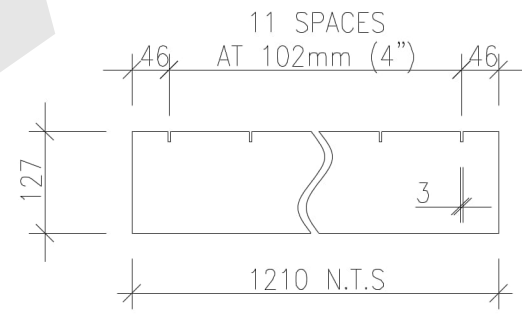

LOAD BAR 'C'

127 x 4.8mm
PLAIN BAR
AROUND ALL
4 SIDES

PANEL DETAIL PLAN
ITEM I.D. #9663691

Notes:

1. All dimensions are in millimeters unless noted otherwise.
2. Grid to be galvanized in accordance with latest CSA G-164 standard.
3. Spacer Bars: To be raised 1mm tack weld joints.
4. Load Bars 'B': Weld on one side only at each end.
5. Load Bars 'C': Deep weld at each location.
6. Maximum opening of 13mm between load bars.

BILL OF MATERIAL

DESCRIPTION	QTY.	LENGTH
127 X 4.8mm	2	459
127 X 4.8mm	2	1210
S.B. 'A' 25 X 3.2mm	15	449
L.B. 'B' 76 X 4.8mm	13	1210
L.B. 'C' 127 X 4.8mm	12	1210
WEIGHT 121KG (267LBS)		

DISTRIBUTION CONSTRUCTION STANDARD
Civil Construction - Material Fabrication



Approved By:
J.D. 2011-10-11
Drafted By:
A.S.
Designed By:
J.D.

Original Issue:
G.D. C.P. 2002-11-25

VAULT EXHAUST VENT GRID:
1220 x 457 x 127mm

Scale: N.T.S. Rev: 2 31- 8360 1/1

© CERTIFIED BY TORONTO HYDRO STANDARD <STANDARDS@TORONTOHYDRO.COM>, THIS DOCUMENT IS FOR USE BY TORONTO HYDRO AND AUTHORIZED PERSONS ONLY AS PER THE TERMS IN TORONTO HYDRO STANDARD 00-0002.

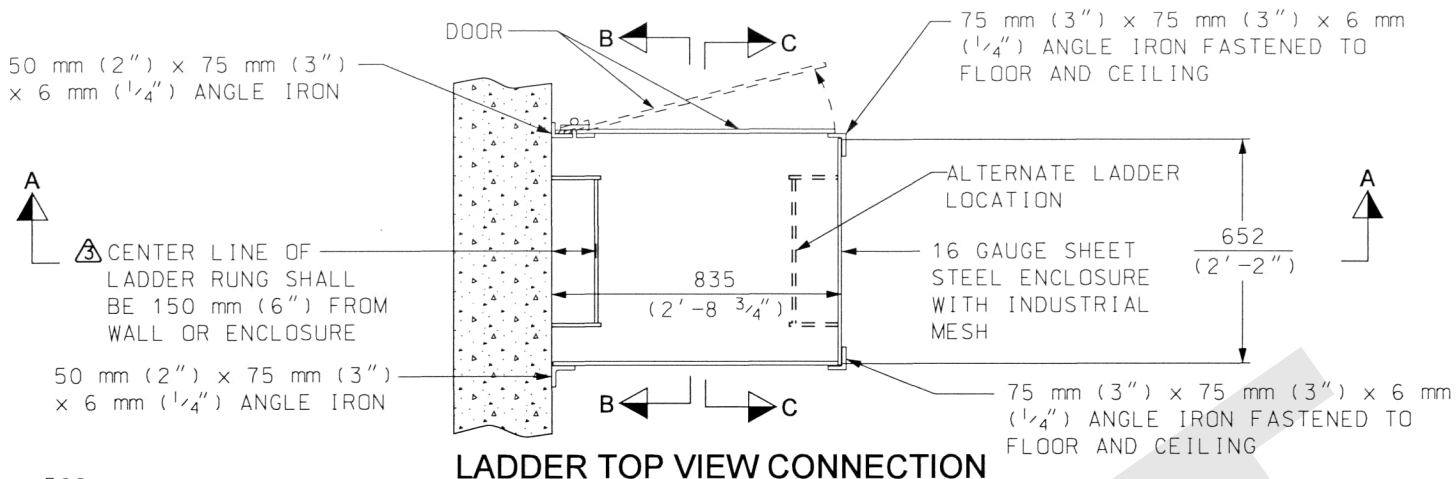

LADDER TOP VIEW CONNECTION

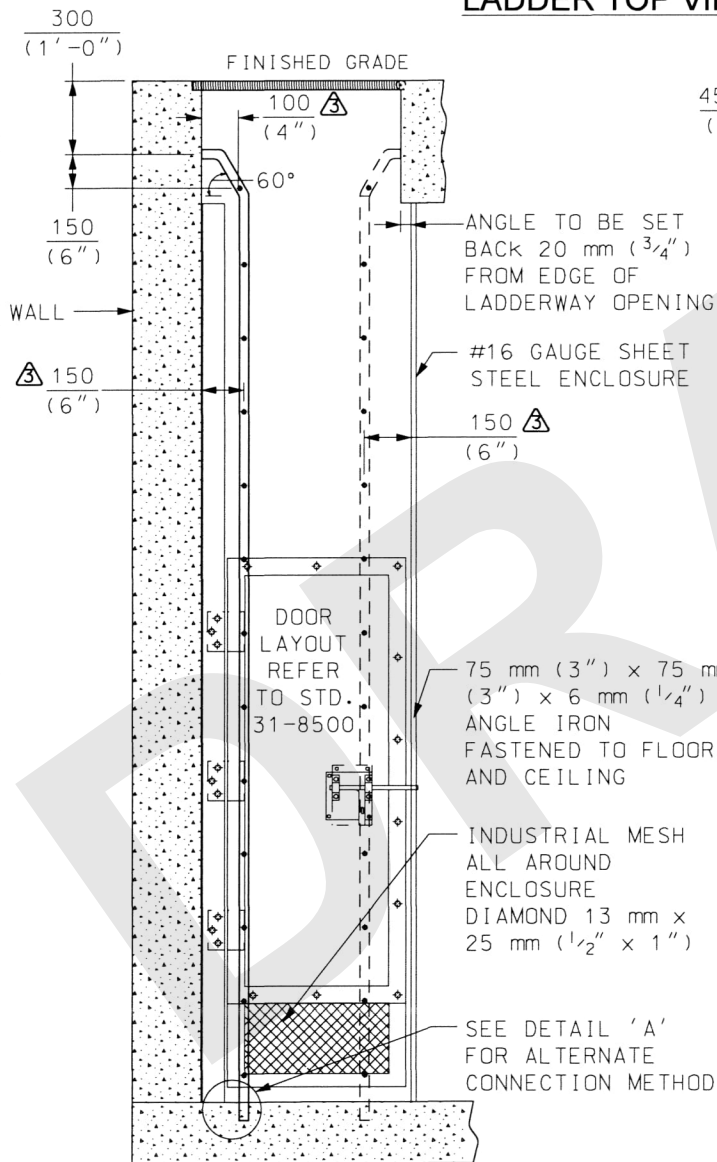

SECTION 'A-A'

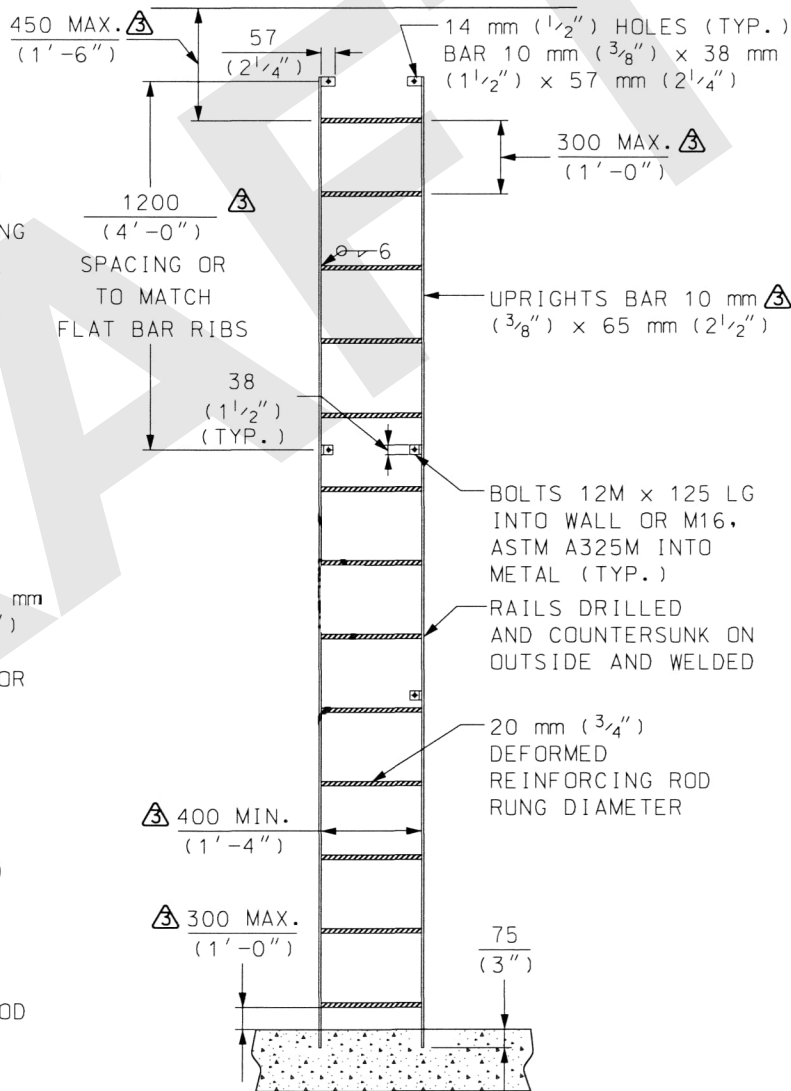

SECTION 'B-B'

DISTRIBUTION CONSTRUCTION STANDARD
Civil Construction

**VAULT
TRANSFORMER VAULT LADDER**



Approved By:
[Signature] 2015/11/16

Drafted By: B.W.
Designed By: J.D.

Original Issue:
G.D. 2000-12-19

Scale:
N.T.S.

Rev:
3

31-8390

1/2

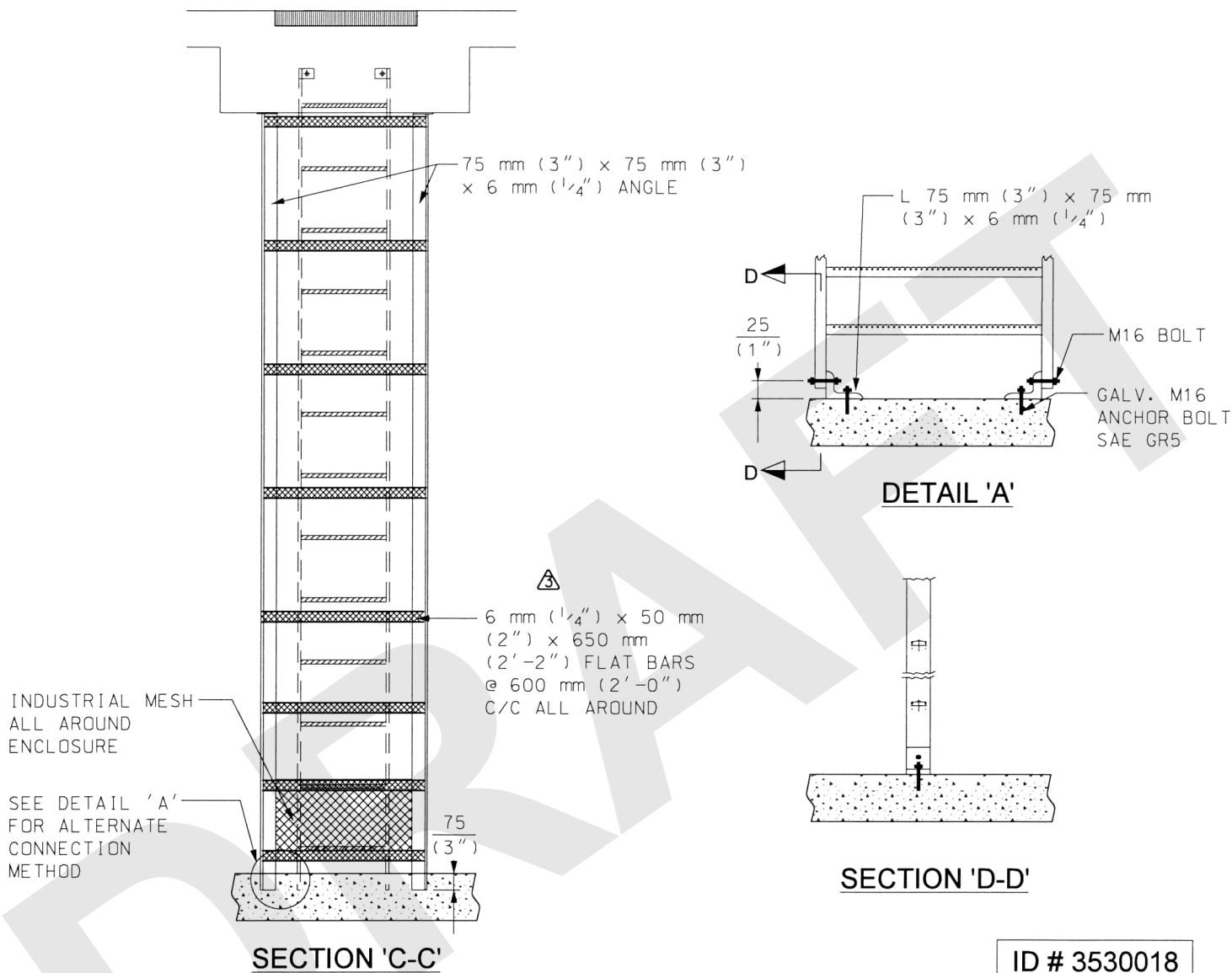

NOTES:

- 1) ALL MATERIAL SHALL BE GALVANIZED IN ACCORDANCE WITH CSA-G-164, EXCEPT HINGES WHICH ARE STAINLESS STEEL.
- 2) STEEL ELEMENTS SHALL BE IN ACCORDANCE WITH CAN3-G312.2-M GRADE 260W.
- 3) REBARS SHALL BE IN ACCORDANCE WITH CAN/CSA-G30.19 (R2014) GRADE 400W.
- 4) LOCATION OF LADDER AND DOOR SHALL BE DETERMINED AS PER CONSTRUCTION DRAWING.
- 5) DOOR AND ENCLOSURE ONLY INSTALLED IN VAULTS WITH HEADROOM GREATER THAN 2200 mm (7'-3").
- 6) INDUSTRIAL MESH MOUNTED ON ALL OPEN SIDES OF THE ENCLOSURE.

DISTRIBUTION CONSTRUCTION STANDARD Civil Construction		VAULT TRANSFORMER VAULT LADDER					
	Approved By: <i>[Signature]</i> 2015/11/16		Original Issue: G.D. 2000-12-19		Scale: N.T.S.	Rev: 3	31-8390 2/2
	Drafted By: B.W.	Designed By: J.D.					

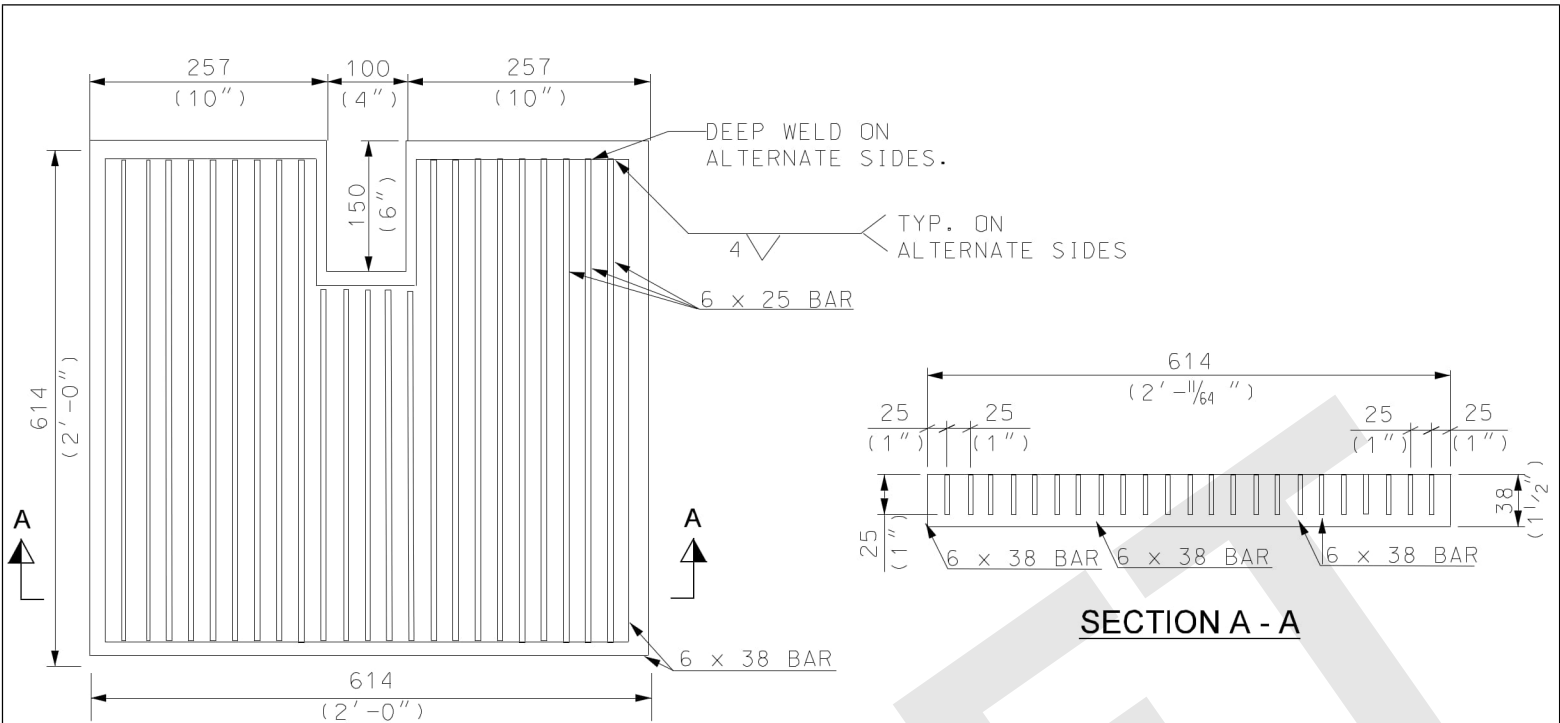

PLAN OF SUMP HOLE GRID

⚠ ID# 3530046

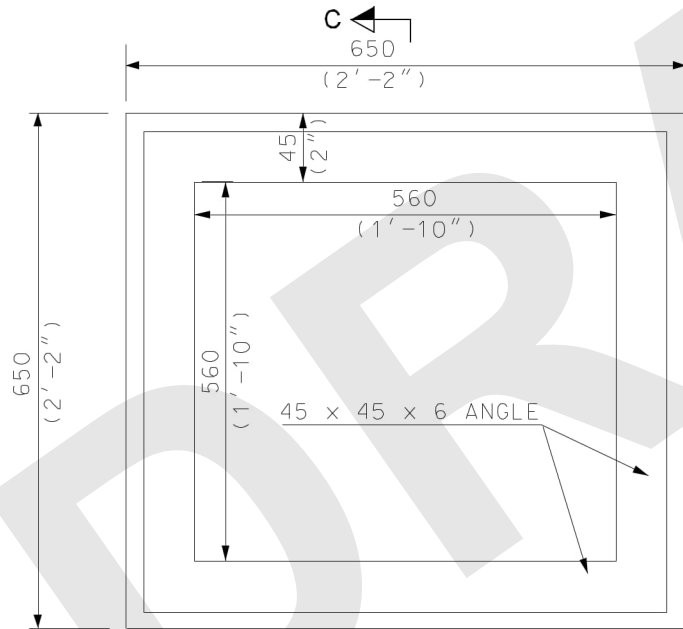

PLAN OF SUMP HOLE FRAME

⚠ ID# 3530530

SECTION A - A

SECTION B - B

NOTES:

- 1) UNIFORM LOADING OF 10 kPa.
- 2) ALL MATERIALS TO BE STEEL WITH $F_u = 400 \text{ MPa}$ MINIMUM AND $F_y = 250 \text{ MPa}$ MINIMUM.
- 3) TO BE GALVANIZED AS PER LATEST EDITION OF CSA STANDARD G-164.
- 4) ALL WELDS TO CONFORM TO LATEST EDITION CSA STANDARD W59.

BILL OF MATERIAL		
GRID		
MATERIAL	LENGTH	QTY.
5 x 38 BAR	611	2 PCS.
5 x 38 BAR	621	1 PC.
5 x 38 BAR	115	1 PC.
5 x 38 BAR	253	2 PCS.
5 x 38 BAR	459	3 PCS.
3 x 25 BAR	605	5 PCS.
3 x 25 BAR	611	2 PCS.
FRAME		
MATERIAL	LENGTH	
45 x 45 x 6 BAR	2642	

DISTRIBUTION CONSTRUCTION STANDARD
Civil Construction

VAULT SUMP HOLE GRID & FRAME:

650 mm x 650 mm x 38 mm

	Approved By:						
	J.D.	2012-03-24					
Drafted By:	Designed By:	Original Issue:	Scale:	Rev:	1	31-8400	1/1
H.M.	J.D.	G.D. 2002-11-15	N.T.S.				

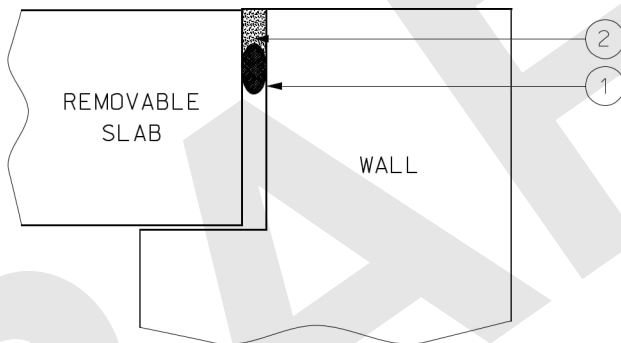
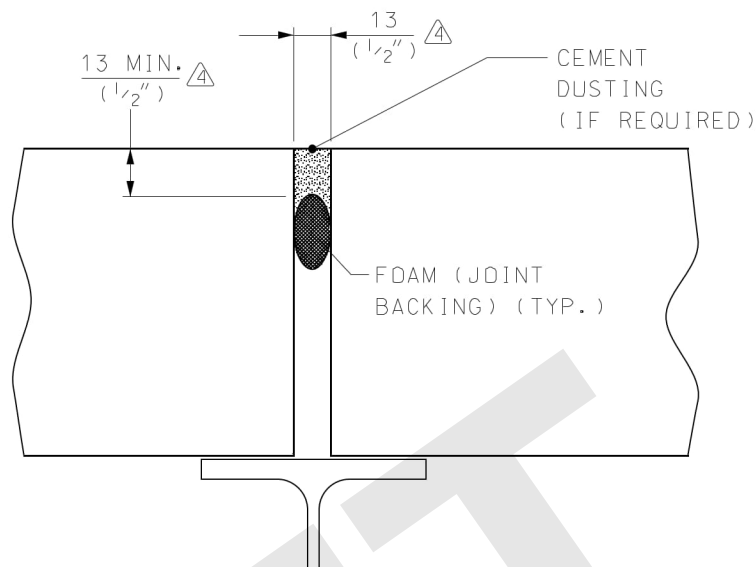
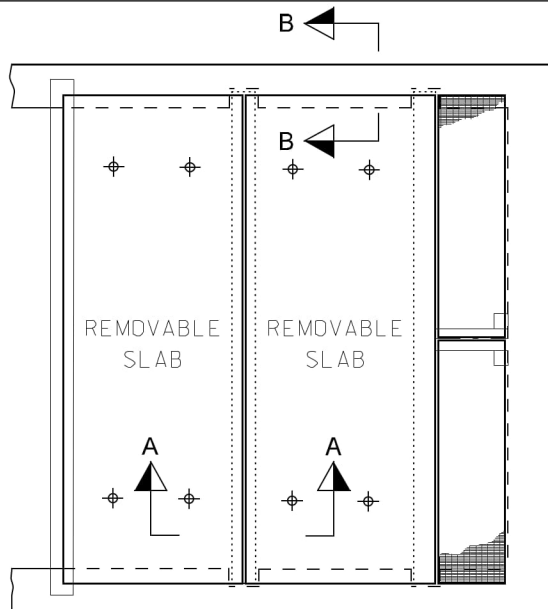

BILL OF MATERIALS FOR 31-8410

ITEM NO.	DESCRIPTION	ITEM I.D.	QTY	
			A	△
1	FOAM 7/8" DIA. X 850' GAP FILLER FOR VAULT SLABS	9664496	1	△
2	COMPOUND JOINT SEALANT 2 PART 5.7 L CONTAINER GREY IN COLOUR	8940080	1	△

NOTES:

- 1) NEW CONSTRUCTION: CONCRETE JOINT INTERFACES SHALL BE CLEAN, DRY AND FREE OF DUST AND LOOSE MATERIAL. A THOROUGH WIRE BRUSHING OR GRINDING MAY BE REQUIRED. THE PRESENCE OF FORM RELEASE AGENTS, OR OTHER CONTAMINANTS SHALL REQUIRE GRINDING TO EXPOSE SOUND, VIRGIN CONCRETE.
- 2) REMEDIAL APPLICATIONS: ALL PREVIOUS SEALANTS, MASTICS OR JOINT FILLERS SHALL BE REMOVED BY ROUTING OR SAW CUTTING. JOINT INTERFACES SHALL BE GRINDED TO EXPOSE SOUND, VIRGIN CONCRETE.
- 3) SEALANT SUPPORT: FOAM (JOINT BACKING) SHALL BE USED TO CONTROL SEALANT DEPTH. FOAM (JOINT BACKING) SHALL BE ROUND.
- 4) MIXING: IF REQUIRED, THE SEALANT SHALL BE THOROUGHLY MIXED IN ACCORDANCE WITH MANUFACTURER'S DIRECTIONS ON CONTAINER LABEL, BEFORE APPLICATION.
- 5) APPLICATION: THE SEALANT SHALL BE APPLIED DIRECTLY FROM THE CONTAINER INTO JOINTS OR BY STANDARD CAULKING GUN.

△6) IF EXISTING JOINT IS LARGER THAN THE SPECIFIED 13 mm (1/2"), LARGER GAP FILLERS ARE AVAILABLE: FOAM 1" DIA. GAP FILLER (9664495) AND FOAM 1 1/4" DIA. GAP FILLER (9664494)

DISTRIBUTION CONSTRUCTION STANDARD
Civil Construction

MATERIAL FABRICATION
CAULKING OF REMOVABLE SLABS



Approved By:
B.D. 2018-08-31

Drafted By:
U.K.

Designed By:
B.D.

Original Issue:
G.D. /C.P. 2002-11-15

Scale:
N.T.S.

Rev:
4

31-8410

1/1

© CERTIFIED BY TORONTO HYDRO STANDARD <STANDARDS@TORONTOHYDRO.COM>, THIS DOCUMENT IS FOR USE BY TORONTO HYDRO AND AUTHORIZED PERSONS ONLY AS PER THE TERMS IN TORONTO HYDRO STANDARD 00-0002.

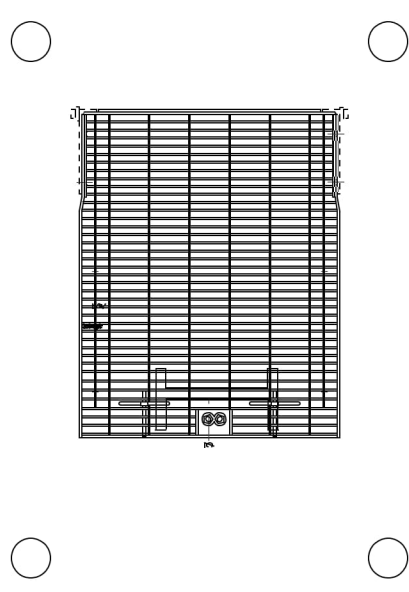

**LADDERWAY
PLAN VIEW**

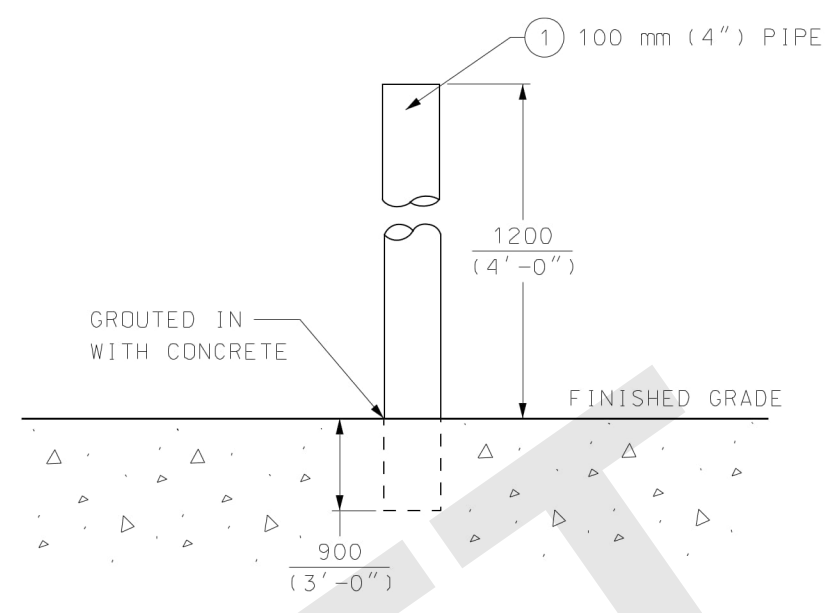

PIPE BARRIER EMBEDDED IN PAVED AREA

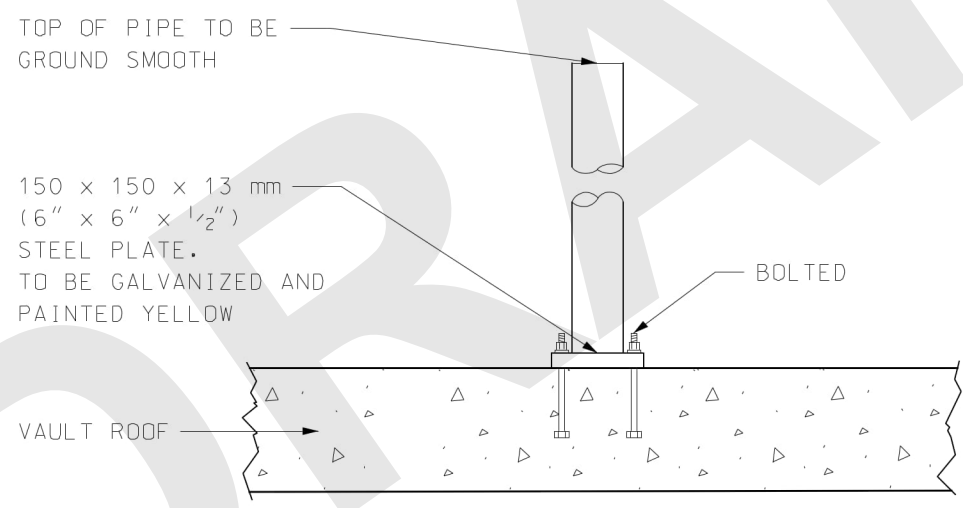

PIPE BARRIER BOLTED TO ROOF

BILL OF MATERIALS FOR 31-8450			
ITEM NO.	DESCRIPTION	ITEM I.D.	QTY
1	100 mm (4") PIPE	9652745	4

- NOTES:** ⚠
- 1) PIPE SHALL BE FILLED WITH CONCRETE WHEN INSTALLED.
 - 2) PIPE SHALL BE GALVANIZED AND PAINTED YELLOW.
 - 3) ALL HARDWARE SHALL BE GALVANIZED IN ACCORDANCE WITH CSA-G-164.

DISTRIBUTION CONSTRUCTION STANDARD Civil Construction		LADDERWAY PIPE BARRIER				
	Approved By:			Scale:	Rev:	1
	J.D.	2013-11-07		N.T.S.		
	Drafted By:	Designed By:	Original Issue:			31-8450
	K.H.	J.D.	G.D./C.P.	2002-11-15		
						1/1

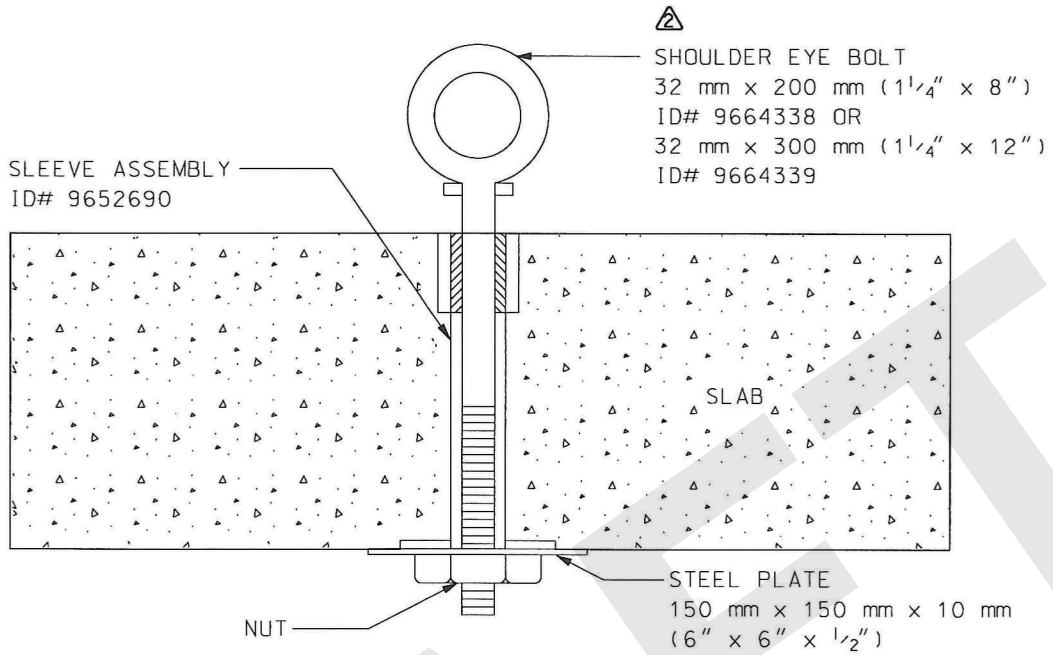

SECTION SHOWING METHOD OF LIFTING

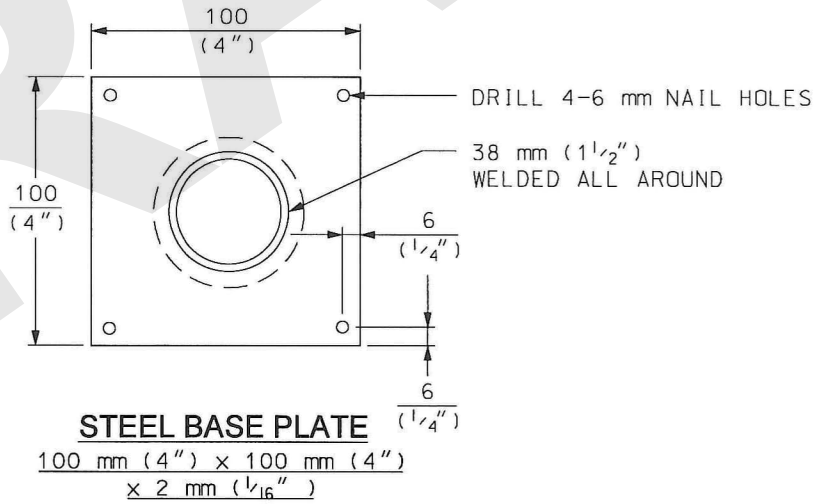

NOTES:

1) ASSEMBLY SHALL BE GALVANIZED IN ACCORDANCE WITH CSA-G-164.

DISTRIBUTION CONSTRUCTION STANDARD
Civil Construction



Approved By:
Daniel 2016/05/25
Drafted By: D.C.
Designed By: J.D.

MATERIAL FABRICATION	
SLEEVE - LIFTING FOR REMOVABLE CONCRETE SLAB	
Original Issue: G.D. 2002-11-15	Scale: N.T.S. Rev: 2
31-8470	1/1

© CERTIFIED BY TORONTO HYDRO STANDARD <STANDARDS@TORONTOHYDRO.COM>; THIS DOCUMENT IS FOR USE BY TORONTO HYDRO AND AUTHORIZED PERSONS ONLY AS PER THE TERMS IN TORONTO HYDRO STANDARD 00-0002.

6 x 50 FLAT IRON TO BE OFFSET AT BOTH ENDS TO SIT FLUSH WITH FACE OF ANGLES AND GAL. STEEL

1.6 mm (16 GA.) GAL. STEEL BOLTED WITH M6 x 1 x 25 mm R.H. BOLTS

LOCK COVERED WITH SHEET OF RUBBER 152 x 203 AND FASTENED WITH 25 mm BAND IRON

75 x 75 STAINLESS STEEL BUTT HINGES FASTENED WITH M6 x 1 x 25 mm R.H. BOLTS

ALL HOLES TO BE DRILLED 7 mm FOR M6 x 1 x 25 mm R.H. BOLTS

FRAME OF DOOR MADE OF 6 x 38 F.I. WELDED

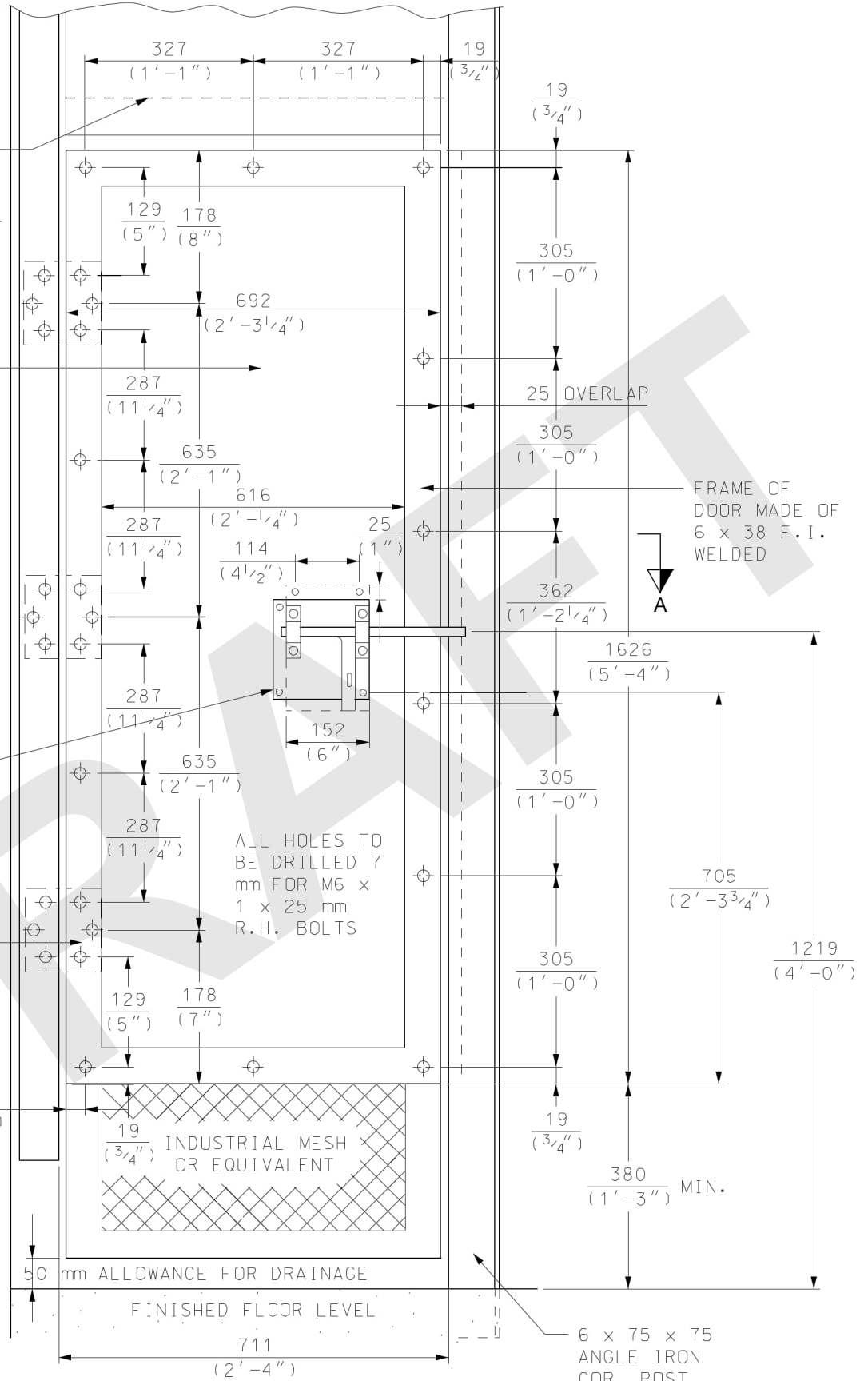

SECTION A-A

DISTRIBUTION CONSTRUCTION STANDARD
Civil Construction

MATERIAL FABRICATION
DOOR FOR TRANSFORMER VAULT



Approved By:
J.D. 2013-11-07

Drafted By: D.L.
Designed By: J.D.

Original Issue:
G.D./L.G. 2002-11-15

Scale:
N.T.S.

Rev:
1

31-8500

1/3

© CERTIFIED BY TORONTO HYDRO STANDARD <STANDARDS@TORONTOHYDRO.COM>; THIS DOCUMENT IS FOR USE BY TORONTO HYDRO AND AUTHORIZED PERSONS ONLY AS PER THE TERMS IN TORONTO HYDRO STANDARD 00-0002.

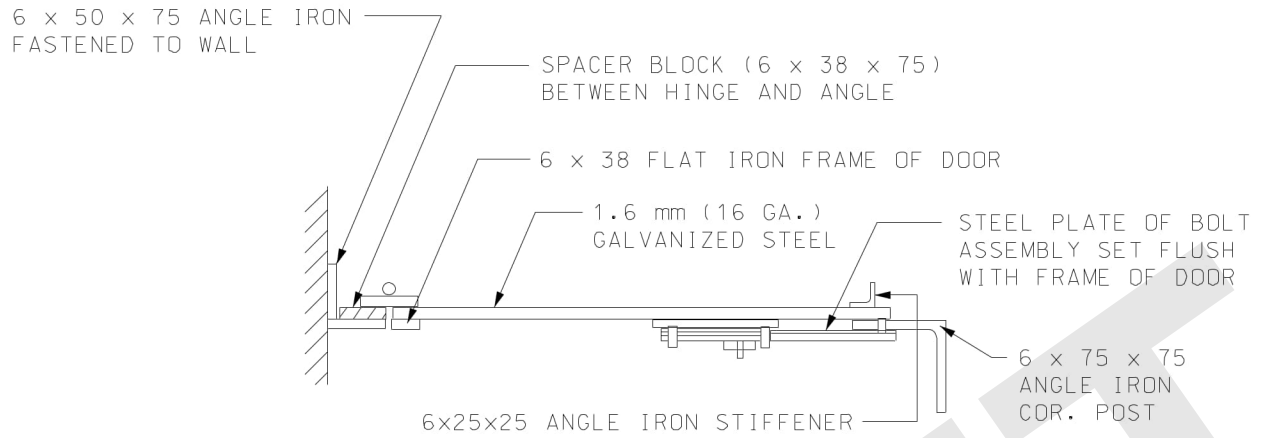

SECTION A-A

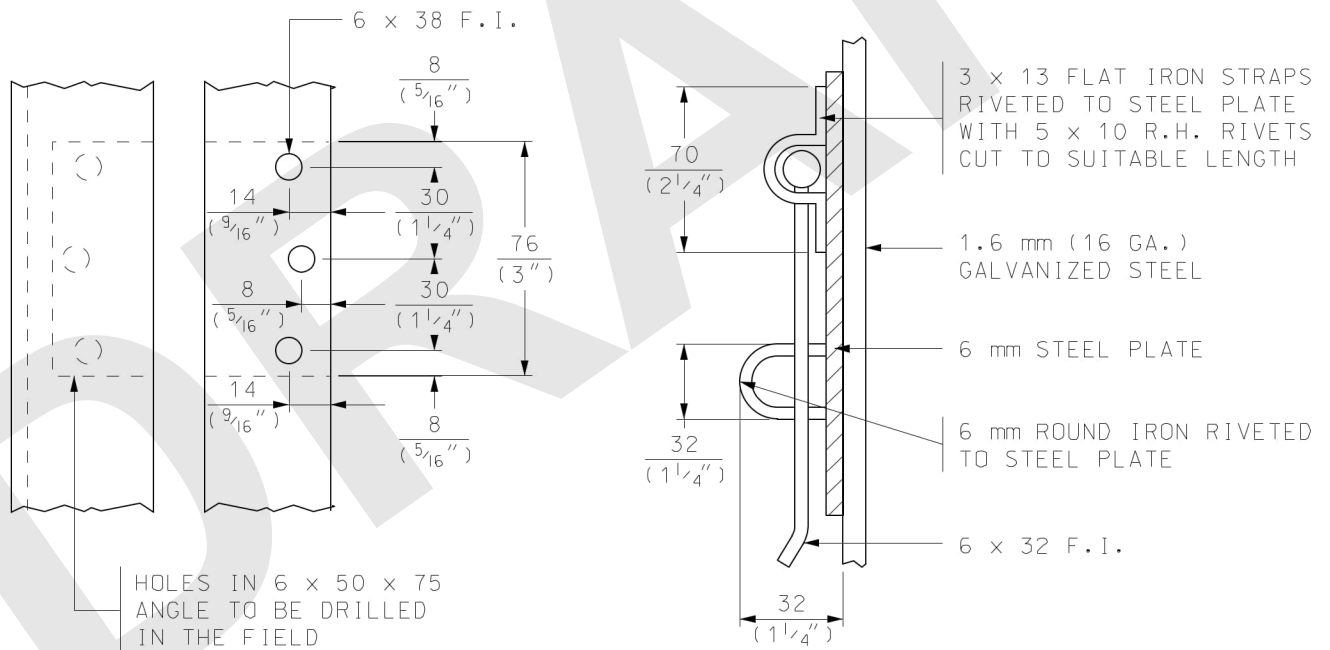

DETAIL OF HINGE

SECTION B-B

DISTRIBUTION CONSTRUCTION STANDARD
Civil Construction



Approved By:
J.D. 2013-11-07

Drafted By: D.L.
Designed By: J.D.

Original Issue:
G.D./L.G. 2002-11-15

Scale:
N.T.S.

Rev: 1

31-8500

2/3

**MATERIAL FABRICATION
DOOR FOR TRANSFORMER VAULT**

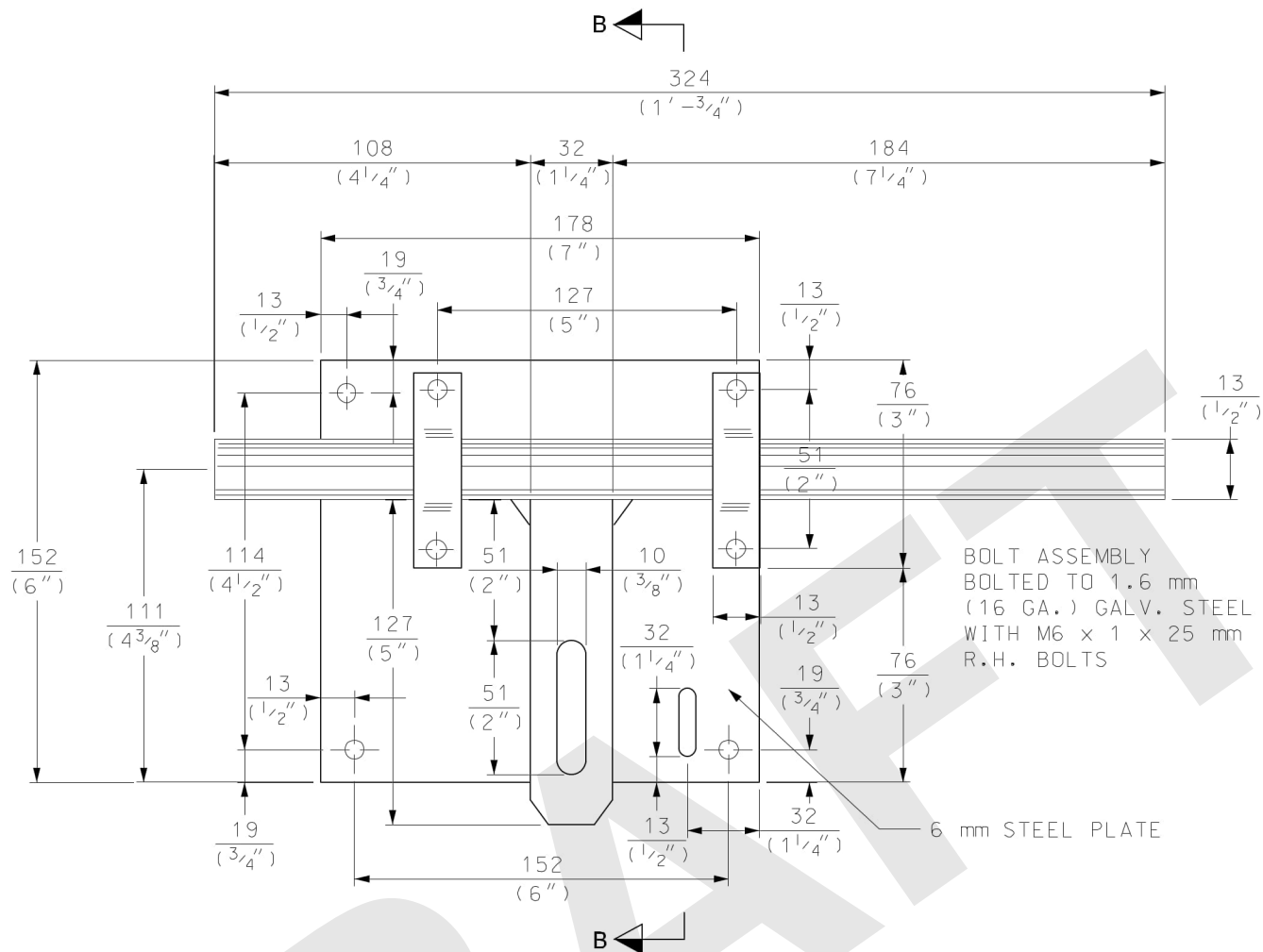

DETAIL OF BOLT

BILL OF MATERIALS	
DESCRIPTION	QTY.
6 mm x 38 mm FLAT IRON	5944 mm
6 mm x 32 mm FLAT IRON	127 mm
6 mm x 50 mm FLAT IRON	705 mm
13 mm ROUND IRON	229 mm
6 mm ROUND IRON	89 mm
6 mm x 25 mm x 25 mm ANGLE IRON	1626 mm
6 mm STEEL PLATE 152 mm x 178 mm	1 PC
3 mm x 13 mm F.I. STRAPS, 95 mm LONG	2 PCS
75 mm x 75 mm HEAVY BUTT HINGES	1 1/2 PR
5 mm x 16 mm R.H. RIVETS	4
1.6 mm GALV. STEEL, 1626 mm x 717 mm	1 PC
M6 x 1 x 25 mm R.H. BOLTS	52
RUBBER SHEET, 152 mm X 203 mm	1 PC
25 mm BAND IRON	152 mm
6 mm F.I. SPACER BLOCKS 38 mm x 75 mm	3 PCS

DISTRIBUTION CONSTRUCTION STANDARD
Civil Construction



Approved By:
J.D. 2013-11-07

Drafted By: D.L.
Designed By: J.D.

Original Issue:
G.D./L.G. 2002-11-15

**MATERIAL FABRICATION
DOOR FOR TRANSFORMER VAULT**

Scale:
N.T.S.

Rev:
1

31-8500

3/3