



TORONTO HYDRO

REQUIREMENTS FOR

THE DESIGN AND CONSTRUCTION

OF

CUSTOMER-OWNED HIGH VOLTAGE SUBSTATIONS

Issued: April 30, 2004
Revision #1: February 28, 2005
Revision #2: February 10, 2006
Revision #3: January 23, 2007
Revision #4: August 15, 2011
Revision #5: October 18, 2012
Revision #6: December 17, 2013
Revision #7: November 30, 2015
Revision #8: October 21, 2016
Revision #9: August 28, 2017
Revision #10: September 21, 2018
Revision #11: August 30, 2019
Revision #12: September 21, 2020
Revision #13: Jan 1, 2025

PREPARED BY: Igor Simonov, P. Eng.

ENGINEER, STANDARDS

REVIEWED BY: Sushma Narisetty-Gupta, P. Eng.

DIRECTOR, STANDARDS

CERTIFICATE OF APPROVAL	
THIS TECHNICAL SPECIFICATION MEETS THE SAFETY REQUIREMENTS OF SECTION 4 OF ONTARIO REGULATION 22/04	
 _____ PROFESSIONAL ENGINEER	2025/01/01 _____ DATE

Table of Contents

1. SCOPE	5
1.1 Toronto Hydro Requirements	5
1.2 Enclosed Switchgear.....	5
1.3 Ontario Electrical Safety Code and Ontario Building Code	5
1.4 SI Units	5
2. PURPOSE.....	6
3. DEFINITIONS	6
4. EXTENT OF TORONTO HYDRO JURISDICTION	7
4.1 Point of Entry to Protective Devices.....	7
4.2 Jurisdiction Coverage Extension.....	7
5. METHOD OF SUPPLY	8
5.1 Number of Feeders	8
5.1.1 One-Feeder Supply	8
5.1.2 Two-Feeder Supply	8
5.1.3 Dedicated Feeder Supply	8
5.2 Incoming Supply.....	9
5.3 Automatic Load Transfer (Automatic Transfer Switch).....	9
5.4 Feeder Termination.....	10
5.5 Duplicate Metering	10
5.6 Temporary Supply	10
6. PROCEDURE FOR OBTAINING TORONTO HYDRO APPROVAL.....	11
6.1 Drawings.....	11
6.2 Additional Drawings.....	11
6.3 Manufacture of Equipment – Drawing Approval	11
6.4 Inspection of Equipment Prior to Shipment.....	11
6.5 Compliance with Requirements.....	11
6.6 Additional Dielectric Strength Tests.....	11
6.7 Dual Locks.....	12
6.8 Automatic Transfer Relay Settings	12
6.9 Pre-Service Inspection Report and Final Connection	12
6.9.1 As Constructed Drawings	12
6.9.2 Transformer and Cable Tests Requirements	13
7. DRAWINGS AND INFORMATION REQUIRED FOR APPROVAL	14
7.1 Substation Drawings	14
7.2 Single Line Diagram.....	15
7.3 Specifications of Electrical Equipment.....	15
7.4 Switchgear Assembly Drawings	16
7.5 Single Line and Schematic Wiring Diagrams.....	16
7.6 Protection Co-ordination and Arc Flash Studies.....	16
7.7 Compliance Letter for Above Grade Substation	16
7.8 Exceptions to Requirements	17
7.9 Final Documents.....	17
8. SUBSTATION REQUIREMENTS.....	17
8.1 General Requirements.....	17
8.1.1 Substation Location	17
8.2 Exits and Doors.....	18
8.2.1 Means of Egress and Exit Door Requirements	18
8.2.2 Legislation and Specific Requirements	18
8.3 Cable Pulling	19
8.4 Cable Racks and Conduits	19
8.5 Outdoor Substations – Fence and Gates	20
8.6 Safe Working Space	20

8.6.1	Working Space About Equipment	21
8.6.2	Minimum Space Requirement	21
8.6.3	Side or Rear Access Panels.....	21
8.6.4	Aisle Space	21
8.6.5	Blocking of Exit Route	21
8.6.6	Illumination of Equipment.....	22
8.6.7	Accessibility for Maintenance	22
8.7	Access to Substation by Toronto Hydro	22
8.8	Communication Requirements	22
8.9	SF6 Switchgear.....	23
8.10	Power Supply.....	23
8.11	Single Line Diagram.....	23
9.	EQUIPMENT REQUIREMENTS.....	24
9.1	System Parameters/Ratings.....	24
9.2	Enclosures.....	24
9.2.1	Sheet Steel Enclosures	24
9.2.2	Electro-magnetic Effects	24
9.2.3	Design of Enclosures	25
9.2.4	Ventilation	25
9.2.5	Enclosure Interiors.....	25
9.2.6	Mimic Bus	25
9.2.7	Name Plates	25
9.3	Compartmentation	25
9.3.1	Separate Compartments	25
9.3.2	Compartment and Openings	26
9.3.3	Intercompartmental Primary Connections	26
9.3.4	Exceptions	26
9.4	Access Doors	27
9.4.1	Doors for Compartments	27
9.4.2	Hinged Access Doors	27
9.4.3	Padlock Hasps.....	28
9.4.4	Securing Access Doors	28
9.4.5	Stops on Access Doors	28
9.5	Screen Doors.....	28
9.5.1	Single Access Doors	28
9.5.2	Screen Approval	28
9.6	Viewing Windows	29
9.7	Toronto Hydro Incoming Feeder Terminations	29
9.7.1	Types of Cables and Terminations	29
9.7.2	Scope of Materials Supply.....	29
9.7.3	Bottom Entry Cables	30
9.7.4	Top Entry Cables.....	31
9.7.5	Line Side Cables or Bus	31
9.8	Barriers	31
9.8.1	Requirement for Barriers	31
9.8.2	Horizontal Barriers	32
9.8.3	Type of Barriers.....	32
9.9	Lightning Arresters.....	32
9.10	Voltage Indicators.....	32
9.11	Circuit Breaker.....	32
9.12	Control Power Supply.....	33
9.13	Fuses	33
9.13.1	Power Fuse Minimum Rating	33
9.13.2	Power Fuse Gas Expelling Type.....	33
9.13.3	Dual Fuse.....	33
9.14	Loadbreak Switches.....	34
9.14.1	Minimum Ratings.....	34

9.14.2	Type of Switch.....	34
9.14.3	Operating Mechanism.....	34
9.14.4	Switch Contacts	34
9.14.5	Operating Warning Sign.....	34
9.15	Isolating Switches.....	35
9.15.1	Location of Switches	35
9.15.2	Switch Requirement	35
9.15.3	Isolation for Vacuum or SF6 Type Circuit Breakers/Switches.....	35
9.16	Electrical Clearances	35
9.16.1	Conductors.....	35
9.16.2	Connection Clearances	35
9.17	Interlocks	35
9.17.1	Incoming Circuit Breakers or Loadbreak Switches	35
9.17.2	Incoming Isolating Switch.....	36
9.17.3	Access Door of Power Fuse Compartment.....	36
9.17.4	Loadbreak Switch on Outgoing Circuit	36
9.17.5	Circuit Breaker on Outgoing Circuit	36
9.17.6	Customer Service Loadbreak Switch.....	36
9.17.7	Marking of Interlock Keys.....	36
9.17.8	Circuit Breaker Used Instead of Fuse	37
9.17.9	Fixed Type Circuit Breaker	37
9.18	Grounding.....	37
9.18.1	Additional Grounding.....	37
9.18.2	Grounding Facilities	37
9.18.3	Cable Compartment.....	37
9.18.4	Voltage Transformer Compartment.....	38
9.18.5	Metallic Parts.....	38
9.18.6	Ground Grid Connections.....	38
9.19	Automatic Transfer between Normal and Standby Supply.....	38
9.19.1	Notification Requirements.....	38
9.19.2	Automatic Transfer Functional Requirements.....	38
9.20	Emergency Backup and Embedded Generation Facilities	40
9.21	Line Differential Relay Protection.....	40
9.21.1	Toronto Hydro Scope of Supply	40
9.21.2	Customer Scope of Supply	40
9.22	Test Blocks	41
9.23	Annunciation – SF6 Low Pressure	41
9.24	Protective Relays	41
9.24.1	Relay Settings.....	41
9.24.2	Current Transformer Secondary Wiring	42
9.24.3	Protection of Cable Tie.....	42
9.25	Faulted Circuit Indicators	42
9.26	Transformers.....	42
9.27	Arc Flash Warning Signs.....	43
9.28	Re-used, Refurbished or Modified High-Voltage Equipment	43
9.28.1	Switchgears.....	43
9.28.2	Transformers.....	43
10.	METERING REQUIREMENTS	45
11.	ASSOCIATED PUBLICATIONS	45
12.	SKETCHES	47

1. SCOPE

1.1 Toronto Hydro Requirements

This publication covers the design, construction, substation layout and the electrical equipment located in Customer-Owned High Voltage Substations. Any exceptions to this publication shall be brought to the attention of Toronto Hydro in writing at the drawing approval stage. The requirements are in addition to the latest edition of:

- a) The requirements for the "Supply Authority" as covered in the Ontario Electrical Safety Code;
- b) The "Conditions of Service" published by Toronto Hydro;
- c) The "Toronto Hydro Requirements for the Design and Construction of Customer-Owned Structures";
- d) The "Toronto Hydro Distributed Generation Requirements";
- e) The "Toronto Hydro Metering Requirements for 13.8 kV & 27.6 kV Customer-Owned Substations";
- f) Associated Publications in [Section 11](#).

1.2 Enclosed Switchgear

These requirements cover metal enclosed (indoor or outdoor) switchgear. Open type switchgear may be acceptable if appropriate protective and gang-operated isolating device(s) is installed between the Customer facility and Toronto Hydro system. Additional conditions on metering may be required for open-type switchgear.

1.3 Ontario Electrical Safety Code and Ontario Building Code

Unless exceptions are granted by the governing Authorities, nothing contained in these requirements shall prejudice or supersede any regulations or requirements of the Ontario Electrical Safety Code (OESC) and Ontario Building Code.

1.4 SI Units

All dimensions and weights are stated in metric units. Equivalent measurements will be accepted if equipment or materials are not manufactured in metric units.

2. PURPOSE

These requirements are intended to provide guidance to Toronto Hydro Customers in designing and constructing 13.8 kV or 27.6 kV Customer-Owned Substations for the purpose of:

- (a) Assuring safe conditions for Customer and Toronto Hydro personnel in operating and maintaining Customer-Owned Substations.
- (b) Assuring a continuity of supply to all Customers by the use of adequate specifications and proper design factors.

3. DEFINITIONS

acceptable	Meets Toronto Hydro requirements.
approval	Approval of drawings and Customer's equipment is limited to Toronto Hydro's requirements and does not construe as acceptance of liability arising from faulty design or workmanship.
compartment	A subdivision of a Unit.
Customer	Refer to Conditions of Service – Main Document Glossary of Terms for definition.
Customer-Owned Substation	A customer-owned civil structure accommodating customer-owned electrical equipment connected to Toronto Hydro 13.8 kV or 27.6 kV system.
Embedded Generation Facility	Means a generation facility which is not directly connected to the IESO-controlled grid but instead is connected to a distribution system.
Embedded Generator	A generator whose generation facility is not directly connected to the IESO-controlled grid but instead is connected to a distribution system.
Emergency Backup Generation Facility	Means a generation facility that has a transfer switch that isolates it from a distribution system.
exit	A path of travel which leads from a floor area to a separate building, an open public thoroughfare or an exterior open space which is protected from fire exposure from the building and has access to an open public thoroughfare.
Former Toronto Area	The geographical area comprising the former Toronto district, that excludes the former Scarborough, North York, York, East York and Etobicoke districts.
high voltage	In this document context, high voltage means 13.8 kV or 27.6 kV.
IESO	Independent Electricity System Operator

means of egress	A continuous path of travel provided for the escape of persons from any point in a building or contained open space (i.e. Substation) to an open public thoroughfare. The means of egress includes the exit and the access to the exit.
MSG	Manufacturer’s Standard Gauge for uncoated steel.
NETA	InterNational Electrical Testing Association
Unit	A full height and full depth module of a switchgear assembly. It is sometimes referred to as “cell”, “cubicle”, “section” or “enclosure”.
vault	An isolated enclosure with fire-resistant walls, ceiling and floors, for the purpose of housing transformers and/or other electrical equipment.

4. EXTENT OF TORONTO HYDRO JURISDICTION

4.1 Point of Entry to Protective Devices

For the purpose of these requirements, Toronto Hydro jurisdiction normally covers the equipment between the point of entry of the supply cables into the Customer’s property and the load side of the first protective devices, i.e. fuses or circuit breakers.

4.2 Jurisdiction Coverage Extension

Toronto Hydro jurisdiction is extended beyond the above limits to cover:

- (a) Toronto Hydro metering equipment when located on the load side of the first protective devices.
- (b) Protective devices located on the load side of the first protective devices in cases where the first protective devices cannot function as required with the Toronto Hydro feeder protection.
- (c) Interlocks intended to prevent paralleling the Toronto Hydro incoming lines when located beyond the area described in [Section 4.1](#).
- (d) Interlocks which prevent the paralleling of an Emergency Backup Generator with the Toronto Hydro supply.
- (e) Any equipment which may affect the safety of Toronto Hydro personnel.
- (f) For safety and security reasons, the Customer must obtain approval from Toronto Hydro before operating the incoming load break switches or circuit breakers.

5. **METHOD OF SUPPLY**

The conditions of supply for Customer-Owned Substations are outlined in Section 2 of the Conditions of Service.

5.1 Number of Feeders

5.1.1 One-Feeder Supply

Typical one-feeder supply arrangements are shown in sketches 1 [\(B-1\)](#), 1 [\(C-1\)](#), and 1 [\(C-2\)](#).

5.1.2 Two-Feeder Supply

Typical two-feeder supply arrangements are shown in sketches 1 [\(D-1\)](#), 1 [\(E-1\)](#), 1 [\(E-2\)](#), 1 [\(F-1\)](#), 1 [\(F-2\)](#), 1 [\(G-1\)](#), 1 [\(H-1\)](#), 1 [\(H-2\)](#), 1 [\(J-1\)](#), and 1 [\(J-2\)](#), and 1 [\(J-3\)](#).

With two-feeder supply, the feeders are not permitted to operate in parallel. One feeder (Normal) will normally carry the total Customer's load and the other (Standby) will remain open on potential. Automatic Transfer Switching may be installed only on 13.8 kV radial feeders to improve reliability [Refer to [5.3](#) and [9.19](#)].

If a split-bus arrangement sketches 1 [\(H-1\)](#) and 1 [\(H-2\)](#) are employed, each of the two feeders can carry its own load but the tie-switch (or tie-breaker) must be open to prevent paralleling of the two feeders. In this arrangement, Customer must ensure that the transformer secondaries on either side of the split-bus be electrically separated (not paralleled). The Customer shall not install any equipment to permit electrical connection between transformer secondaries across the split bus.

5.1.3 Dedicated Feeder Supply

A feeder is deemed "dedicated" when only one Customer connection can be connected to the feeder due to high loading requirements and to satisfy Toronto Hydro's thermal requirements. Toronto Hydro shall determine, in its sole discretion, when dedicated feeders are required for a Customer connection.

13.8 kV System

When two or more feeders are designed to operate in parallel, circuit breakers and line differential (pilot wire) relay protection and remote trip receiving relay(s) shall be required [Refer to sketch 1 [\(I-1\)](#)].

The number of dedicated feeders shall be based on the following:

- 2 feeders: $8 \text{ MVA} \leq \text{Customer Peak Load} < 10 \text{ MVA}$
- 3 feeders: $10 \text{ MVA} \leq \text{Customer Peak Load} < 20 \text{ MVA}$
- 4 feeders: $20 \text{ MVA} \leq \text{Customer Peak Load} < 30 \text{ MVA}$
- 5 feeders: $30 \text{ MVA} \leq \text{Customer Peak Load} < 40 \text{ MVA}$

The number of dedicated feeders is based on using 500 kcmil, Copper, TRXLPE, Triplex cable.

Line differential relay protection arrangement is provided at the sole discretion of Toronto Hydro. Additional conditions and costs may apply.

27.6 kV System

When Customer demand load is greater than or equal to 18 MVA then dedicated feeders are required. The number of dedicated feeders and the design connection shall be based on Table 1 below:

Table 1 - Dedicated Feeder Installations

Customer Peak Load	Number of Dedicated Feeders	Feeder Cable Sizing	Design Configuration
$18 \text{ MVA} \leq \text{Load} \leq 28 \text{ MVA}$	2	1000 kcmil, Copper, TRXLPE	- two feeders sharing the load. Refer to sketch 1 (H-2)

Subject to Toronto Hydro approval, line differential relay protection arrangement may be provided to Customer supplied by the 27.6 kV System. Additional conditions and costs may apply.

5.2 Incoming Supply

For the 27.6 kV system, the Customer shall provide the necessary concrete encased ductbank, splice vault, and pad foundation for the installation of Toronto Hydro switchgear on Customer property. Toronto Hydro shall provide feeder cabling and switchgear at the Customer’s cost. This switchgear installation is applicable to sketches 1 [\(H-2\)](#), [\(J-1\)](#), [\(J-2\)](#), and [\(J-3\)](#).

5.3 Automatic Load Transfer (Automatic Transfer Switch)

Subject to Toronto Hydro approval, an automatic load transfer may be employed only on 13.8 kV system and where the Customer requires a higher degree of service reliability than that afforded by other methods of supply.

Each feeder is connected to the Customer's switchgear through a circuit breaker (or motorized loadbreak switch) one of which is normally closed and carrying load, the other open and on potential. Automatic transfer is initiated on a voltage sensing basis, the voltage sensing being obtained from potential transformers located on the source side of incoming feeder breakers (or motorized loadbreak switch) [Refer to [9.19](#) for details].

5.4 Feeder Termination

Each feeder shall be terminated in the Customer's switchgear and shall be connected to the Customer's bus either through a circuit breaker equipped with a primary disconnecting device or through a loadbreak switch [Refer to sketches 1 ([B-1](#)) through 1 ([J-3](#))]. Terminating more than one feeder in the same compartment is not acceptable [Refer to [9.3.1](#)].

5.5 Duplicate Metering

Where a Customer has a two-feeder arrangement Normal and Standby, [Refer to sketch 1 ([G-1](#))] that requires dual metering, the Customer shall be responsible for the additional metering cost.

5.6 Temporary Supply

- (a) Toronto Hydro will provide a temporary supply of electricity for construction of the Customer-Owned Substation on Customer's property. Toronto Hydro will determine the method of temporary supply which may be either a primary or secondary connection, and the temporary transformation is installed within the road allowance or on Customer property.
- (b) Temporary installation for the Customer-Owned Substation shall meet the ratings and requirements as specified in this document.
- (c) Construction sites with no space for temporary transformation facilities on Customer's property may be required to install temporary Customer-Owned facilities on a raised platform within the city road allowance. This temporary installation is permitted with the written approval from the City of Toronto. Customers are to refer to construction standard 15-8510 (posted on Toronto Hydro website) for the details of conduit installation to a raised platform.
- (d) Upon completion of the Customer's facilities the temporary installation shall be disconnected and removed.

6. PROCEDURE FOR OBTAINING TORONTO HYDRO APPROVAL

Following acceptance of a Customer's application for a 13.8 kV or 27.6 kV supply or a proposal to modify an existing 13.8 kV or 27.6 kV substation, the procedure shall be as follows:

6.1 Drawings

The Customer shall submit to Toronto Hydro for approval the drawings and information listed in [Section 7](#).

6.2 Additional Drawings

If the drawings or information do not meet Toronto Hydro requirements or are not sufficiently clear, then revised or additional drawings and information must be submitted on request.

6.3 Manufacture of Equipment – Drawing Approval

Manufacture of equipment should not start until all drawings and information have been approved by Toronto Hydro. This will avoid costly changes to completed equipment. Final revised drawings must be delivered to Toronto Hydro at least four weeks prior to the delivery of the switchgear to the substation site.

6.4 Inspection of Equipment Prior to Shipment

Toronto Hydro reserves the right to inspect the completed equipment at the manufacturer's plant prior to shipment.

6.5 Compliance with Requirements

When the installation of the switchgear has been completed, the Customer shall utilize a qualified testing agency and subject the switchgear to a Dielectric Strength Test. The voltage applied shall be 75% of the factory test voltage in accordance with clause 8.5.1 of CSA Standard C22.2 No. 31 "Switchgear Assemblies". Toronto Hydro shall witness the testing of the switchgear by the qualified testing agency during normal working hours. Notice of witness testing date shall be submitted to Toronto Hydro at least 2 weeks in advance. A test report certified by a Professional Engineer shall be submitted for approval before the energization of switchgear.

6.6 Additional Dielectric Strength Tests

Should the switchgear fail to pass the Dielectric Strength Test, the Customer shall make the necessary modifications and a further dielectric test shall be performed.

6.7 Dual Locks

A u-bolt dual locking facility is required on the operating handle of the incoming switchgear to allow locking in the open or closed position. Either Toronto Hydro or the Customer can open the lock. The Customer must consult Toronto Hydro before any closing operations.

6.8 Automatic Transfer Relay Settings

Where circuit breakers or automatic transfer switches are used, Toronto Hydro personnel shall witness the setup of the relays and the testing of the protection and control devices for correct operation of these devices.

6.9 Pre-Service Inspection Report and Final Connection

A pre-service inspection report shall be submitted to Toronto Hydro for approval prior to final connection of supply to Customer substation. Toronto Hydro reserves the right to carry out additional inspections. A Connection Authorization from the Electrical Safety Authority is also required prior to final supply connection.

The pre-service inspection report shall include the following items and shall have a conclusion on whether or not the substation is satisfactory for energization.

6.9.1 As Constructed Drawings

The pre-service inspection contractor shall have a Professional Engineer certify that the Customer's installation was completed in accordance with the original drawings that were approved by Toronto Hydro and return a set of these drawings to Toronto Hydro to keep on file as "As Constructed" drawings. The drawings to be certified must be original, photocopies are not acceptable. [Refer to Section 7 for drawings and information required for approval].

6.9.2 Transformer and Cable Tests Requirements

The following transformer and cable tests shall be certified by a Professional Engineer:

6.9.2.1 Transformer Test Requirements

- Turns Ratio (all taps)
- Insulation Resistance (Mega-Ohms for 60 seconds, indicate test voltage)

6.9.2.2 High Voltage Cable Test Requirements

Customer owned high voltage cables shall be tested by one of below listed methods:

Method 1

Test voltage applied as follows: Duration shall be 15 minutes with leakage reported in microamperes at 1-minute intervals.

System Voltage	Test Voltage
13.8 kV AC	54 kV DC
27.6 kV AC	86 kV DC

Method 2

Test voltage applied as follows:
 60 Hz AC or VLF (0.1Hz) Sinusoidal Withstand monitored with Partial Discharge (PD).
 Below table outlines test levels depending on the underground cable system rating and type of test performed.

System Voltage	Cable Rating	Test Levels RMS Phase-to-Ground	
		60 Hz	0.1 Hz VLF
13.8 kV AC	15 kV	34 kV	21 kV
27.6 kV AC	28 kV	40 kV	36 kV
Duration		1 min	60 min

PD acceptance level are defined as a factor of normal phase-to-ground operating voltage (U_0). Test Report per the latest IEEE 400.2 shall include the cable and termination ratings and correspondent withstand voltage as well as minimum PDEV (partial discharge extinction voltage) for each component under test.

7. DRAWINGS AND INFORMATION REQUIRED FOR APPROVAL

Copy of each of the drawing and information listed in [7.1](#) to [7.8](#) inclusive shall be submitted to Toronto Hydro, for approval. Additions and modifications to existing equipment shall be clearly indicated.

All drawings shall be approved and stamped by a Professional Engineer (P.Eng) of Ontario before submission to Toronto Hydro for review.

Drawings listed in [7.4](#) are not required to be approved and stamped by a P.Eng, if a switchgear assembly is CSA approved. CSA approval shall be indicated on the drawings as well as on the equipment nameplate, or by having CSA equipment approval sticker.

Drawings shall be fully dimensioned and scaled. Photo-reduced copies of the original and unapproved drawings shall not be accepted.

All dimensions shall be in S.I. units.

7.1 Substation Drawings

Drawings shall indicate:

- (a) Site Plan: The location of the substation relative to buildings, structures, property lines, the nearest public thoroughfare, and other equipment in the vicinity of the substation including vehicular and personnel access route.
- (b) Distribution Power Riser diagram with exact location of indoor substation.
- (c) The proposed route of Toronto Hydro incoming supply cables, including details of primary duct bank.
- (d) The location of any pipes or ducts in the vicinity of the substation, e.g. ventilating ducts, water, gas, sewage pipes, sprinkler system, access openings, windows, vehicle access, access direction, etc.
- (e) Layout of the equipment in the electrical room clearly indicating aisle clearances and exits.
- (f) Details of cable pits, ducts or vaults.
- (g) Details of substation grounding arrangements and location of any ground grids used.

- (h) Details and location of meter cabinet. [Refer to [Section 10](#) and the Conditions of Service].

7.2 Single Line Diagram

The following information shall be included in the drawing:

- (a) Ratings, impedances and taps of the main transformers.
- (b) Ratings and short circuit capabilities of circuit components.
- (c) Details of all primary cables e.g. voltage, size, material, etc.
- (d) Interlocking arrangements with an explanation of operational sequences.
- (e) Proposed protective relaying scheme, where applicable, showing relay types and instrument transformer ratios and accuracy.

7.3 Specifications of Electrical Equipment

These shall include dimensions, ratings, manufacturer, type, and other technical information.

7.4 Switchgear Assembly Drawings

Drawings shall provide the following information:

- (a) Plan, elevation and sectional views (front and side) of the switchgear assembly including working clearances.
- (b) Grounding details. [Refer to [9.18](#)].
- (c) Provisions for Toronto Hydro metering equipment. [Refer to [Section 10](#) and the Conditions of Service].
- (d) Provisions for access to components. [Refer to [9.4](#) and [9.5](#)].
- (e) Description of principal components.
- (f) Details of barriers [Refer to [9.8](#)].
- (g) Electrical clearances [Refer to [9.16](#)].
- (h) Interior paint finish [Refer to [9.2.5](#)].
- (i) Name plate.
- (j) Interlock scheme and dual lock provision.
- (k) Provision for Faulted Circuit Indicators.
- (l) Provision for termination of supplementary bonding or neutral conductor

7.5 Single Line and Schematic Wiring Diagrams

These shall include AC single line and DC schematic drawings and connection wiring diagrams of the protection and control equipment used in conjunction with circuit breakers and motor operated switches. [Refer to sketch 5 ([A-1](#))].

7.6 Protection Co-ordination and Arc Flash Studies

All Customer devices associated with the 13.8 kV or 27.6 kV equipment shall coordinate with Toronto Hydro upstream protection. Toronto Hydro shall provide upstream protection information as required. Customer shall submit Protection Coordination and Arc flash studies reports for review for compliance with Toronto Hydro requirements.

7.7 Compliance Letter for Above Grade Substation

Letter stating that the elevated structure is designed and constructed in compliance with all applicable codes and regulations and is rated for intended structural loading.

7.8 Exceptions to Requirements

Nothing contained in the submitted drawings and information shall be construed as permitting any modification to the Requirements of this document unless such modification is approved in writing in advance by Toronto Hydro. Any non-compliances to the Requirements shall be clearly defined by the Customer in a separate letter or an appendix entitled: "Exceptions to Requirements for the Design and Construction of Customer-Owned High-Voltage Substations". Any proposed exceptions remain subject to approval of Toronto Hydro.

7.9 Final Documents

The Customer shall submit the final documents mentioned above to Toronto Hydro for approval. Failure to provide Toronto Hydro with the final documents may delay the substation connection to the Toronto Hydro supply system.

8. **SUBSTATION REQUIREMENTS**

8.1 General Requirements

The substation shall be constructed and equipped in accordance with the relevant standards, governmental codes and regulations.

8.1.1 Substation Location

The substation shall be located on the ground level. Any alternative substation locations shall require Toronto Hydro approval. It is the Customer's responsibility to ensure all Customer-owned structures constructed to house Customer-owned Equipment and/or Toronto Hydro's Facilities and Equipment must be impermeable to water, hazardous materials and gas. Toronto Hydro shall not be responsible for any damage caused by the leakage of water, hazardous materials or gases entering or exiting any Customer-Owned Structure.

Above ground level location including elevated structures may be accepted provided that:

- (a) Overall installation complies with the latest OESC and Ontario Building Code.
- (b) Substation transformers are dry type or contain non-propagating liquid with a flash point not less than 275°C. Transformers for temporary installation may have insulation liquid with a flash point less than 275°C, provided that they meet the requirements of [Section 9.28.2](#) of this document.
- (c) Installation is protected from vehicle impact either by design or by external barriers.

8.2 Exits and Doors

8.2.1 Means of Egress and Exit Door Requirements

A minimum of two separate means of egress each with an exit door and located at opposite side of the substation area are required. Each means of egress shall allow a separate escape route to exit from any point in the substation area to an open public thoroughfare. The exit doors shall open in the direction of exit travel and shall be equipped with panic type hardware.

At least one of the doors shall be fitted with a keyed cylinder lock and a handle on the opposite side of the door from the panic bar, in a form acceptable to Toronto Hydro.

Each exit door shall be equipped with an EXIT sign as per latest Ontario Building Code.

Entrance and exit doors must remain clear of obstructions at all times.

8.2.2 Legislation and Specific Requirements

The exits shall conform to the latest revision of the Ontario Building Code and “The Ontario Occupational Health and Safety Act, and Regulation for Industrial Establishments – Part II – Buildings” from which the following are extracted:

- (a) OHSA Rules 122 states that:
 - (1) This section applies with respect to a hazardous room,
 - (a) With an area greater than fifteen square meters; or
 - (b) Requiring a distance of travel greater than 4.5 m from any point in the room to an egress doorway.
 - (2) A hazardous room shall be located in a floor area that has at least two exits.
 - (3) A hazardous room shall have at least two egress doorways that are at least three-quarters of the length of the diagonal distance of the room from each other.
 - (4) One egress doorway must be located within a maximum distance of twenty-three meters from any point in a hazardous room.
- (b) If doors are used they shall open in the direction of exit travel and swing on their vertical axes. (Direction of Door Swing – Ontario Building Code, latest edition).
- (c) The door(s) must open readily from inside the room at all times it is occupied. Locks shall not require a key to operate from inside.
- (d) Where more than one door is employed, all doors shall be equipped with panic hardware.
- (e) Doors equipped with panic hardware must open under 90 N releasing pressure applied in the direction of exit travel. (Door Release Hardware – Ontario Building Code, latest edition).

- (f) Panic hardware must be located between 0.76 m and 1.12 m above floor level on room doors.
Note: Where double doors are used; only one of the pair requires panic hardware.
- (g) Where the exit doors open into an area where the means of egress may be impeded by vehicular traffic, protective removable bollards shall be installed by the Customer.
- (h) Cable Pull Room Doors – 1.5 hr fire rated doors or better shall be supplied and installed by the Customer. For cable installations over 750 V, “High Voltage” warning signs shall be installed on the door. The fire doors and frames, ventilating shafts or louvered windows for ventilation are to be grounded.

8.3 Cable Pulling

Cable pulling loops or eyes shall be installed by the Customer opposite the incoming duct faces in Customer’s electrical room, pull room or cable chamber. In addition, the following shall be adhered to:

- (a) Where the service entrance must be in such a location that underground cables cannot be pulled directly into the electrical room, the Customer shall provide an acceptable cable pull room, or cable chamber to be used as an intermediate pull location. [Refer to the Toronto Hydro Conditions of Service Requirements for the Design and Construction of Customer-Owned Structures].
- (b) Clearance for pulling cable – In all circumstances, space must be available for a straight cable pull between the duct face and the pulling loop or eye. Where there is less than 3.0 m clear space from the duct face to the pulling loop or eye, every effort should be made to locate the room door in the wall opposite the duct face. If a door is not practical, an opening close to the floor level and with a removable cover should be provided in the wall containing the pulling loop or eye.

8.4 Cable Racks and Conduits

- (a) Where required, cable supports, racks, and mechanical protection shall be supplied and installed at the Customer’s expense.

Cable trays shall not be used for Toronto Hydro cables between the duct face and entry to the Customer owned switchgear. Conduit Installations on Customer’s premises for Toronto Hydro incoming cables shall conform to OESC and Toronto Hydro’s standard practices [Refer to the Toronto Hydro Conditions of Service Requirements for the Design and Construction of Customer-Owned Structures].

- (b) The maximum length of the cable from the duct face to the Customer owned switchgear shall not exceed 7.5 m. The installation shall meet the requirement of Ontario Electrical Safety Code.

- (c) To prevent access by unauthorized persons, all Toronto Hydro high voltage cables in the Customer vault shall be guarded by barriers. Provided barriers such as enclosures around cables or a removable duct banks hatches shall have provisions for Toronto Hydro padlocks. The Customer is responsible for providing all material associated with the cable routing and support between the duct and a power cable termination point.

8.5 Outdoor Substations – Fence and Gates

(a) Guarding of Electrical Equipment

- (i) Outdoor substations shall be surrounded by guarding fence and gates in accordance with OESC rule 26-300 and [Section 8.6](#) of this document.
- (ii) Subject to Toronto Hydro approval, tamper resistant equipment may be excluded from requirements of (i) when proof of tamper resistant rating is provided (e.g. type test reports, compliance with 36 series of OESC Bulletins). The tamper resistant rating shall be indicated on the equipment nameplate.

(b) Height of Fence

The fence, excluding barbed wire, shall not be less than 1.8 m high.

(c) Barbed Wire

The fence shall be topped with not less than three strands of barbed wire. Barbed wire is not required for the equipment already protected by elevation.

(d) Gates

- (i) Gates shall preferably open outwardly but, if it is necessary that they open inwardly, they shall not come into contact with the frame or enclosure of any electrical equipment when fully opened; a clear passageway at least 0.9 m wide and 2.2 m high shall be maintained to ensure safe egress.
- (ii) Double gates with center stops shall be used where the width of opening exceeds 1.5 m.
- (iii) All gates shall have security provision for accepting both Customer and Toronto Hydro padlocks; also, “High-Voltage Warning” signs shall be affixed to them.

(e) Grounding

Substation grounding shall meet the requirements of Ontario Electrical Safety Code, 36-300 to 36-312.

8.6 Safe Working Space

Safe working space in vicinity of service entrance equipment including metering shall be in accordance with the Ontario Electrical Safety Code Rule 2-308 and shall include the following:

8.6.1 Working Space About Equipment

- (a) A minimum working space of 1.0 m with secure footing shall be provided and maintained about electrical equipment such as switchboards, panel boards, control panels and motor control centres which are enclosed in metal, except that working space is not required behind such equipment where there are no renewable parts such as fuses or switches on the back and where all connections are accessible from locations other than the back. [Also refer to [8.6.2](#) for Toronto Hydro clearances].
- (b) The space referred to in [8.6.1\(a\)](#) shall be in addition to the space required for the operation of draw-out type equipment in either the connected, test, or fully disconnected position and shall be sufficient for the opening of enclosure doors and hinged panels to at least 90°.
- (c) Working space with secure footing not less than that specified in Table 56 of Ontario Electrical Safety Code – Minimum Working Space About Electrical Equipment Having Exposed Live Parts, shall be provided and maintained about electrical equipment such as switchboards, control panels and motor control centres having exposed live parts.
- (d) The minimum headroom of working space about switchboards or motor control centres where bare live parts are exposed at any time shall be 2.2 m.
- (e) Sprinkle piping shall not be installed above Customer equipment compartments that have top entry termination of incoming Toronto Hydro cables.

8.6.2 Minimum Space Requirement

A minimum of 1.9 m shall be provided in front of all doors giving access to switchgear components and where Toronto Hydro is required to work.

8.6.3 Side or Rear Access Panels

Where removable side or rear access panels are required, a minimum working space of 0.9 meter with 2.2 m clear headroom shall be maintained.

8.6.4 Aisle Space

A clear passageway at least 0.9 m wide and 2.2 m high shall be maintained as an exit route from all service entrance equipment. This headroom must also be maintained in the working space in the vicinity of the service entrance equipment.

8.6.5 Blocking of Exit Route

Where the compartment hinged doors or drawout components would block the exit route then a clear minimum space of 0.6 m must be maintained from the edge of the access door or components in the fully open position.

8.6.6 Illumination of Equipment

Adequate illumination shall be provided to allow for proper operation and maintenance of electrical equipment in accordance with Ontario Electrical Safety Code Rule 2-316. The lighting shall be controlled by wall switches located at the entrances to these areas.

8.6.7 Accessibility for Maintenance

Passageways and working space around electrical equipment shall not be used for storage and shall be kept clear of obstruction and so arranged as to give authorized persons ready access to all parts requiring attention in accordance with Ontario Electrical Safety Code Rule 2-312.

8.7 Access to Substation by Toronto Hydro

Immediate access to the substation must be provided on a 24-hour basis for Toronto Hydro personnel. A door equipped with a Toronto Hydro lock, giving direct access to the substation from the outside (e.g. street) shall be provided where practicable. Alternatively, the doors along the route leading to the substation must be equipped with Toronto Hydro locks.

If Toronto Hydro locks are not practical, the Customer shall provide Toronto Hydro the appropriate access keys or magnetic cards to enable entry from outside (e.g. street) to the substation. Toronto Hydro shall supply and install a key box at a suitable location to safekeep the key(s).

8.8 Communication Requirements

To ensure that radio communication with the Toronto Hydro Control Centre is adequate, Toronto Hydro may, in its sole discretion, require the Customer to provide provisions for indoor substations for communication equipment installation including the following:

- a. 600 mm x 600 mm interior wall space inside of substation for mounting of Toronto Hydro equipment. Allocated space shall be between 1000 mm and 1700 mm above the floor level and be within 1500 mm of 120 VAC power supply (e.g. receptacle), and within 1 m of access/entry door.
- b. 300 mm x 300 mm wall space on outdoor wall of substation structure at least 3 m above ground level for mounting of antenna.
- c. Dedicated civil infrastructure (agreed upon by Toronto Hydro) for running a coaxial cable between equipment installed as per above items a) and b) (e.g. conduit, duct, etc.). The minimum size of conduit/duct shall be 2", with minimum bending radius of 12". Pullbox shall be installed after every two (2) 90 degree bends, with maximum distance of 100 feet between pullboxes.

Toronto Hydro will supply and install the required equipment (e.g. antenna, cable), and assume ownership and maintenance of installed communication equipment.

8.9 SF6 Switchgear

Where SF6 switchgear is installed inside the substation, a means of annunciation of low SF6 gas pressure shall be provided to the outside of the substation. This annunciation shall consist of an external warning light installed above each access entrance. A sign stating “Low SF6 Gas Pressure” shall be mounted above the external warning light. A “Lamp Test” button shall be installed on the external annunciation unit for means of testing the warning light before entering the substation. [Refer to [9.23\(e\)](#)].

8.10 Power Supply

A 120 V a.c. 15-ampere 2-pole 3-wire grounded receptacle shall be provided close to Toronto Hydro’s incoming feeder compartment. If installed outdoors, the receptacle shall be weatherproof and protected by a ground fault circuit interrupter of the Class A type.

8.11 Single Line Diagram

The Customer shall provide and post a mounted single line diagram (latest revision) of good quality print on a wall in the electrical room for reference. The Customer shall also update the single line diagram to include those switching equipment designations that may be assigned from time to time by Toronto Hydro.

9. EQUIPMENT REQUIREMENTS

9.1 System Parameters/Ratings

Customer equipment shall conform to ratings in Table 2 below:

Table 2 - System Parameters/Ratings

Requirement	13.8 kV	27.6 kV
Rated Continuous Current (min)	600 A	600 A
Rated Nominal Voltage	13.8 kV	27.6 kV
Rated Load Interrupting Capability	600 A	600 A
Rated Maximum Voltage	15 kV	29.3 kV
Rated Frequency	60 Hz	60 Hz
Power Frequency Withstand Voltage	36 kV	60 kV
Basic Impulse Level (BIL)	95 kV	125 kV (Y _G)** 150 kV (Δ) **
Rated System Fault Level (MVA sym)	500 MVA	800 MVA
3-phase Symmetrical Fault Current (rms)	21 kA	17 kA
Rated Momentary Current (rms asym)	34 kA	27 kA
Fault Closing Current (10 Cycles, rms, asym)	40 kA	27 kA
Short Time Withstand Current (rms, sym)	25 kA (2 seconds*)	25 kA (1 second)
Single Line-to-Ground Fault Current (rms)	11 kA	12 kA
Corona Extinction Voltage to Ground	10.5 kV	19 kV
Circuit Breaker Operating duty	CO-15 sec-CO	CO-15 sec-CO
Circuit Breaker Opening Time	5 cycles	5 cycles

* 1 second rating is acceptable for feeders not from the Former Toronto Area, subject to Toronto Hydro's approval

** Y_G - Grounded Wye ; Δ - Delta

Any deviation from the above ratings shall be brought to Toronto Hydro's attention.

9.2 Enclosures

9.2.1 Sheet Steel Enclosures

All enclosures including barriers between compartments containing high voltage components shall be of sheet steel not less than #11 MSG and all other covers, barriers, panels and doors shall not be less than #14 MSG.

9.2.2 Electro-magnetic Effects

To avoid heat generation due to electromagnetic effects when a single conductor or bus penetrates through a magnetic material, stainless steel barriers shall be used. Aluminum barriers are not acceptable. [Also, refer to [Section 9.7.2](#) (c) (ii) for requirements on strain relief connectors].

9.2.3 Design of Enclosures

The switchgear enclosure shall be designed in accordance with the rules of the Canadian Electrical Code, Part I and as defined in latest CAN/CSA Standards C22.2 No. 94.1 and No. 94.2. Heaters shall be used in outdoor switchgear and shall be controlled by humidistat.

9.2.4 Ventilation

Ventilating openings, if required, shall be designed to prevent the entrance into the enclosure of any object, which could come into hazardous proximity to live parts.

9.2.5 Enclosure Interiors

Interiors of enclosures shall be finished in white enamel.

9.2.6 Mimic Bus

A mimic bus on front door of switchgear compartment with no rear access shall indicate the internal electrical arrangement of equipment in each compartment. The mimic bus shall be securely fastened to the panel. For switchgear with rear access, all components, both front and rear, shall be marked and labeled similarly.

9.2.7 Name Plates

Switchgear data nameplates shall be engraved or stamped and mounted in accessible location. Photographic imprinting process is not acceptable.

9.3 Compartmentation

9.3.1 Separate Compartments

The following switchgear components shall be installed within separate compartments formed by sheet steel barriers:

- (a) Each loadbreak switch.
- (b) Each incoming cable termination.
- (c) Each group-operated isolating switch.
- (d) Each circuit breaker.
- (e) Each three-phase set of power fuses.
- (f) Each set of metering current transformers.
- (g) Each set of voltage transformers.

- (h) Each set of metering voltage transformer fuses.
- (i) Where a bus transition from the bottom of the switchgear to the top of the switchgear is required, the transition shall be done in a separate compartment [Refer to [9.3.4\(b\)](#)].
- (j) Where an interface connection is required between the main switchgear bus, and a power transformer in an adjacent compartment, a full metal barrier complete with fully rated through-bushings shall be provided to establish complete segregation of the two compartments.
- (k) For SF6 switchgears in the dual radial system, the two incoming feeders shall not be connected to the same switchgear. A standalone SF6 loadbreak switch in a completely separate enclosure is required abutting the SF6 switchgear with one incoming feeder connected to the SF6 switchgear and the other connected to the SF6 standalone switch.

9.3.2 Compartment and Openings

There shall be no openings whatsoever in compartment walls that shall permit the flow of ionized gases or flame into adjacent compartments.

9.3.3 Intercompartmental Primary Connections

Where the primary connections pass from one compartment to another compartment, the through-bushings installed in non-magnetic barriers shall be rated fully at the same insulation level as the switchgear.

9.3.4 Exceptions

- (a) If the incoming feeders enter the switchgear from the bottom, a single compartment may contain both an incoming cable termination and either a loadbreak switch or an isolating switch provided the switch and all buses are located above the cable termination and the compartment has two access doors, one in front of the switch and one in front of the cable termination. However, a single door may be accepted if a hinged screen door is installed behind the access door. [Refer to [9.5.1\(a\)](#) and [9.8.2](#)].

An additional warning sign “CAUTION, SWITCH BLADES COULD BE LIVE” shall be posted either on the top access door accommodating the incoming line switch in case of two access doors compartment or on the hinged metallic screen door covering the incoming line switch in case of single access door compartment.

- (b) When the transition bus is in the same compartment as the loadbreak switch and separated from the incoming cable termination compartment, a separate compartment is not necessary.

- (c) If a set of power fuses is immediately preceded by a loadbreak switch other than an incoming line switch, then both may be contained in a single compartment provided the switch and all preceding buses are located above the power fuses, and the compartment has two access doors, one in front of the switch and one in front of the fuses. However, a single door may be accepted if a hinged screen door is installed behind the access door [Refer to [9.5.1\(b\)](#) and [9.8.2](#)].
- (d) Fixed fuse supports used in conjunction with the metering voltage transformers may be mounted in the same compartment as the metering current transformers provided the current transformers and all main buses are located above the fuse supports. Two access doors, one in front of the fuse supports, may be used or alternatively a single access door may be used for the compartment. A separate access door is required for the metering voltage transformers.
- (e) Where voltage transformers, for other than revenue metering purposes, are mounted on a drawout or swing-out type carriage their fuses may be mounted on the carriage in the same compartment.
- (f) For 27.6 kV switchgear metering, the current transformers and voltage transformers can be installed in the same compartment. Barriers and voltage transformers fuses are not required.

9.4 Access Doors

9.4.1 Doors for Compartments

Individual hinged access doors are required to give access to the following compartments:

- (a) Each loadbreak or isolating switch.
- (b) Each circuit breaker.
- (c) Each set of power fuses.
- (d) Each set of metering current transformers.
- (e) Each set of voltage transformers.
- (f) Each set of voltage transformer fuses.
- (g) Each incoming feeder cable termination.

9.4.2 Hinged Access Doors

All hinged outer access doors shall open at least 135° and all hinged inner doors or screens shall open at least 90°. Inner doors or screens are not required for SF6 switchgear.

9.4.3 Padlock Hasps

Access doors shall be equipped with padlock hasps measuring at least 30 mm wide and 5 mm thick capable of accepting a standard Toronto Hydro padlock with an 8 mm shackle.

Padlock hasps are not required:

- (a) On access doors equipped with interlocks that prevent access to live components.
- (b) On access doors to withdrawable circuit breaker compartments.

9.4.4 Securing Access Doors

Access doors shall be adequately secured with either 25 mm knurled head captive bolts that require no tools to unscrew, or handles with at least three latching points. For outdoor installation, shrouded penta-head bolts are acceptable alternative.

9.4.5 Stops on Access Doors

Access doors on compartments shall have stops to hold the doors in the fully open position.

Hinged or removable panels other than the access doors specified herein which provide access to high voltage components shall be secured with tool operated screws.

9.5 Screen Doors

9.5.1 Single Access Doors

In the following cases a single access door may be used in lieu of two separate doors provided that it covers the entire opening and a hinged metallic screen is installed behind the single door as described below:

- (a) To cover an incoming line switch installed in the same compartment as a cable termination in accordance with [9.3.4\(a\)](#).
- (b) To cover a loadbreak switch installed in the same compartment with a set of power fuses in accordance with [9.3.4\(c\)](#).

9.5.2 Screen Approval

- (a) Installations using metallic screens according to [9.5.1](#) will be subject to special Toronto Hydro approval that requires the screens to be hinged, bolted and padlocked and have a high voltage warning sign affixed to them. A screen must fully cover the opening, which would normally be covered by the upper of the two separate doors, and there shall be no openings larger than 13 mm in or around the screen. [Refer also [9.8.2](#)]. Metallic screen is not required for SF6 switchgear.

- (b) Refer to [9.3.4\(a\)](#) for additional warning sign in case of bottom entry incoming feeder cables.
- (c) All screens shall be painted flat black.
- (d) Screens must allow all components to be clearly seen.

9.6 Viewing Windows

Viewing windows shall be provided to permit the observation of all switchblades, voltage indicators and incoming cable terminations with the access door closed. Viewing window shall not be of the wire-reinforced type and shall be Section B3.6 of IEEE Std C37.20.2 – 2022.

9.7 Toronto Hydro Incoming Feeder Terminations

9.7.1 Types of Cables and Terminations

- (a) Toronto Hydro will normally supply and install cable from the supply point (on the street) to the termination point on the Customer's switchgear. For existing services, the cables could be either PILC or polymeric. For new services, the cables are to be polymeric only.
- (b) Where paper insulated lead covered cable (PILC) is used, the Customer's switchgear shall have provision for Class 1 terminations (potheads) as defined in the latest edition of IEEE Standard 48. [Refer to [sketch 2](#) for clearance requirements].
- (c) Where single conductor polymeric-insulated cable is utilized, the Customer shall provide space and clearance as shown on [sketch 2](#) so that Class 1 terminations such as heat shrink or cold shrink termination kits can be installed. ANSI 386 elbow terminations are acceptable for SF6 switchgear application.
- (d) In addition to incoming feeders terminations, Customer shall provide a provision for termination of Toronto Hydro supplementary bonding conductor for Delta system or neutral conductor for Ground Wye system.

9.7.2 Scope of Materials Supply

(a) Materials Supplied by Toronto Hydro for PILC and Polymeric Cables

Toronto Hydro will normally supply the following materials:

- (i) Class 1 terminations (potheads – Toronto Hydro standard design) for PILC cables.
- (ii) Class 1 terminations (heat shrink or cold shrink kits) for polymeric cables.
- (iii) Standard 2-hole NEMA lugs for terminating polymeric cables.

- (iv) Strain relief connectors of non-magnetic material for single conductor cables.
 - (v) For SF6 switchgears, ANSI 386 elbow terminations for polymeric cables on the incoming feeders only. Customer will provide terminations for their own connections.
- (b) Materials Supplied by the Customer for PILC Cables
- (i) Aerial lugs (G&W Electric Co. Style 8). Use of non-standard aerial lugs to suit particular switchgear design must be approved by Toronto Hydro.
 - (ii) Non-standard Class 1 terminations, such as angled potheads, to suit particular application.
 - (iii) The mounting plates and gaskets for top entry terminations. [Refer to [sketch 3](#)].
 - (iv) Flexible tinned copper braids, drilled to suit aerial lug and switchgear terminal pad, as well as associated bolting accessories.

The braids shall have sufficient slack between the bolted ends to absorb longitudinal and lateral motion.
 - (v) For standard pothead installation, the Customer shall provide three aerial lugs and three copper braids as spare and shall store in a readily accessible location within the Customer's electrical room. For non-standard (angled) pothead installation, the Customer shall provide one pothead in addition to the items above.
- (c) Materials Supplied by the Customer for Polymeric Cables
- (i) Bus terminal lugs and bolting accessories, if other than standard 2-hole NEMA lugs, suitable to terminate Toronto Hydro cables on switchgear terminal pad (Toronto Hydro shall provide size of conductors).
 - (ii) Gland plate of non-magnetic material for single conductor cables.

9.7.3 Bottom Entry Cables

- (a) PILC cable installations shall have the wiping sleeve of the pothead mounted at least 0.3 m above the base of the switchgear and 1.2 m above the floor of a cable trench [Refer to [sketch 2](#), figure 1]. Adequate clearance shall be furnished between the aerial lug and the switchgear terminal pad for ease of connection of copper braid.
- (b) Polymeric-insulated cable terminations require a minimum vertical distance of 1.0 m from where the cable enters the switchgear to the terminal lug [Refer to [sketch 2](#), figure 2].

- (c) Where a cable trench is used, removable plate shall be installed at the base of each incoming feeder compartment. These shall cover the entire bottom opening of the compartment. Cable entry shall be through a gland plate of non-magnetic material (stainless steel) for single conductor polymeric cables. The minimum depth of the trench shall not be less than 0.9 m.

9.7.4 Top Entry Cables

- (a) For PILC cables, the minimum clearance required above the switchgear is shown on [sketch 2](#), figure 3. Where there is insufficient headroom to accommodate specified clearance, the Customer shall provide suitable Class 1 terminations (angled potheads) and a minimum clearance of 915 mm between the top of the switchgear and the ceiling.
- (b) For single conductor polymeric cables, the terminations require a minimum vertical distance of 0.6 m between the cable entrance to the equipment and the terminal lug [Refer to [sketch 2](#), figure 4]. A removable non-magnetic (stainless steel) gland plate shall be provided at the top of the switchgear.

9.7.5 Line Side Cables or Bus

- (a) Section of switchgear bus or cable situated between incoming feeder cable termination points and the line side of the Customer's first protective device shall not pass any compartment or section of compartment that contain cables or bus that are connected to the load side of the Customer's first protective device.

9.8 Barriers

9.8.1 Requirement for Barriers

Phase to phase and phase to ground barriers [Refer to [9.8.3](#)] shall be installed on the following equipment:

- (a) Each loadbreak switch.
- (b) Each disconnect switch.
- (c) Each set of fixed metering voltage transformer fuses.
- (d) Each set of high voltage power fuses.

Such barriers shall extend from the base of the insulator supports to a point 50 mm beyond the fuse ferrules or the open blades of switches and 50 mm beyond the terminal pads.

9.8.2 Horizontal Barriers

Where cable terminations and loadbreak switches (or isolating switches) or power fuses and loadbreak switches (or isolating switches) are installed in the same compartment in accordance with [9.3.4\(a\)](#) and [9.3.4\(c\)](#), barriers shall be installed so as to prevent anyone working in the lower section of the compartment from reaching up and coming into hazardous proximity with live conductors. (This permits work to be done in the cable termination compartment or power fuses to be changed without de-energizing the whole sub-station).

9.8.3 Type of Barriers

The barriers must be white, flame retardant insulating material meeting NEMA requirements for grade GPO-3 and be a minimum 5 mm thick. Barriers are not applicable for SF6 switchgear application.

9.9 Lightning Arresters

Lightning arresters are not required when substations are supplied from underground feeders. If the Customer wishes to install lightning arresters, they shall be located on the loadside of the first protective device. Selection of lightning arresters shall be based on the actual utility system configuration (e.g. delta, wye configurations, etc.). If the supply to the substation is from overhead system, Toronto Hydro shall install lightning arresters at the pole and the Customer may install lightning arresters in the switchgear on the loadside of the first protective devices. The mimic diagram shall indicate the presence of such devices in the switchgear.

9.10 Voltage Indicators

Voltage indicators shall be supplied and installed by the Customer in the incoming cable termination compartment between the cable termination and the first isolating device. Voltage indicators shall be approved by Toronto Hydro. The voltage indicators must be clearly visible through the viewing window [Refer to [9.6](#)].

Where the incoming cable terminates in a rear compartment and the isolating device is located in the front compartment, two sets of voltage indicators shall be installed, one in each compartment. A viewing window for each set of indicators shall be provided.

9.11 Circuit Breaker

Circuit breakers shall comply with the latest edition of ANSI C37 series of Standards and with the ratings shown in Table 2 in [Section 9.1](#). Self powered circuit breakers may be acceptable for applications that do not require remote tripping.

For aggregate transformer capacity of 5 MVA or greater for 27.6 kV and 3 MVA or greater for 13.8 kV at the point of demarcation, circuit breakers shall be used exclusively at the Customer's first protective device [Refer to sketches 1 ([B-1](#)), 1 ([C-2](#)), 1 ([D-1](#)), 1 ([E-2](#)), and 1 ([F-2](#))].

A legible warning sign stating “Contact Toronto Hydro for permission to operate” shall be posted next to the operating button/handle of the incoming/tie circuit breakers.

9.12 Control Power Supply

The recommended range of voltage for control apparatus is shown in Table 3 below:

Table 3 - Recommended Control Voltage

Type of Control	Voltage	
	Option 1	Option 2
Nominal	125 V dc	48 V dc
Closing Range	90-140 V dc	As per manufacturer’s recommendations
Tripping Range	70-140 V dc	

- (a) Control power supplies for protective equipment such as circuit breakers and relays must attain a high degree of reliability. Where batteries are used to supply protective equipment, a suitable battery monitor must be provided to give an alarm should the battery voltage or state of charge fall below a safe level. Such monitoring device shall be connected to the load side of the battery circuit breaker or isolating switch.
- (b) A test button shall be provided to test all indicating lamps.

9.13 Fuses

Fuses are permitted for aggregate transformer capacity less than 5 MVA and 3 MVA for 27.6 kV and 13.8 kV systems respectively, at the Customer’s first protective device. For transformer capacity of 5 MVA or greater and 3 MVA or greater for the 27.6 kV and 13.8 kV systems respectively, circuit breakers shall be used in lieu of fuses at the Customer’s first protective device [Refer to [9.11](#)].

9.13.1 Power Fuse Minimum Rating

Power fuses shall comply with the ratings specified in Table 2 in Section 9.1.

9.13.2 Power Fuse Gas Expelling Type

When the power fuses are of a type which expel gases during the interruption of short circuit currents, the construction of the enclosure shall follow the fuse

- (a) Clearances between exhaust parts and other metallic parts.
- (b) Mechanical design to withstand internal pressures and shock waves.

9.13.3 Dual Fuse

For SF6 switchgear, Bay-O-Net type fuse with back up current limiting fuse under oil are acceptable for transformer protection.

9.14 Loadbreak Switches

9.14.1 Minimum Ratings

Loadbreak Switches shall comply with the latest CSA Standard C22.2 No. 193 or IEEE C37.74 and shall conform to ratings specified in Table 2 in [Section 9.1](#).

9.14.2 Type of Switch

Each switch shall be 3 pole, group operated by a handle mounted external to the compartment which contains the switch. For SF6 switchgear, each incoming loadbreak switch will have a ground position (to ground incoming feeders) with interlock and/or mechanical stop (to prevent inadvertent grounding) and provision for padlocking. This handle shall be so arranged that the operator may open or close the switch from a position not immediately in front of the switch contacts. The handle shall be equipped with a dual locking device for locking the switch in either open or closed position, suitable for use with a standard Toronto Hydro padlock with 8 mm shackle [Refer to [6.7](#) for dual lock requirements]. Both open and closed positions of the handle shall be clearly labeled. The top of the handle in the closed position shall be no higher than 1.8 m above the floor level.

9.14.3 Operating Mechanism

The operating mechanism of all loadbreak switches shall be designed so that a mechanical failure of a component, linkage, chain, etc., shall not result in an electrical fault and meet the following requirements:

- (a) Switches shall be constructed or mounted such that gravity shall not tend to close them.
- (b) The maximum force on the handle to operate the switch is 16 kg.
- (c) Where chains are used, a securely bolted full chain guard shall be provided.

9.14.4 Switch Contacts

The switch contacts shall be silver-plated or tin-plated. The clearance between the fixed and moving switch contacts in the open position shall conform to the requirements of the latest ANSI C37.32. The open/closed switch contacts shall be visible through the viewing window.

9.14.5 Operating Warning Sign

A legible warning sign stating “Contact Toronto Hydro for permission to operate” shall be posted next to the operating button/handle of the incoming/tie load break switches.

9.15 Isolating Switches

9.15.1 Location of Switches

An isolating switch shall be installed on the line side of an incoming feeder circuit breaker or motorized loadbreak switch to permit incoming feeder isolation and/or grounding.

9.15.2 Switch Requirement

Isolating switches shall be 3 pole, group operated and shall conform to the requirements stipulated in [Section 9.14](#) except that isolating switches need not have a closing or interrupting rating.

9.15.3 Isolation for Vacuum or SF6 Type Circuit Breakers/Switches

Loadbreak switches shall be used for isolation purpose when vacuum or SF6 type circuit breakers/switches are used.

9.16 Electrical Clearances

9.16.1 Conductors

The phase to phase and phase to ground clearances of conductors and other current carrying parts shall be in accordance with the requirements of the latest CSA Standard C22.2 No. 31.

9.16.2 Connection Clearances

Where 13.8 kV or 27.6 kV connections are made to any components supplied or installed by Toronto Hydro (e.g. current and voltage transformers, fuses, cable terminations), such connections shall be assumed to be bare and full CSA through air clearances shall be maintained.

9.17 Interlocks

Refer to sketches 1 ([A-1](#)) through 1 ([J-3](#)).

9.17.1 Incoming Circuit Breakers or Loadbreak Switches

Unless a split-bus arrangement is used [Refer to sketch 1 ([H-1](#)), ([H-2](#))] the two loadbreak switches or circuit breakers on the incoming lines shall be interlocked to ensure that not more than one switch or circuit breaker is in the closed position at any time. Provision shall be made, however, so that Toronto Hydro personnel, by the use of an additional key, may close both switches or circuit breakers simultaneously and thus permit the load to be transferred from one incoming feeder to the other without interruption to the service [Refer to sketches 1 ([D-1](#)) to 1 ([G-1](#))].

9.17.2 Incoming Isolating Switch

Isolating switch located on the line side of the incoming circuit breaker shall be of the loadbreak type.

9.17.3 Access Door of Power Fuse Compartment

- (a) In installations incorporating power fuses on outgoing circuits, an interlock shall be provided to prevent the access door of the outgoing circuit power fuse compartment from being opened unless the loadbreak switch preceding the power fuse is open, and to prevent the preceding switch from being closed until the power fuse compartment door has been locked closed [Refer to sketches 1 (B-1) to 1 (J-3)].
- (b) In installations incorporating power fuses as the overcurrent protection for the Customer service, interlock shall be provided to prevent the access door of the Customer service power fuse compartment from being opened unless the adjacent loadbreak switches (or circuit breakers) on both the line side and load side of the Customer service power fuse are open, and to prevent these switches (or circuit breakers) from being closed until the Customer service power fuse compartment door has been locked closed [Refer to sketches 1 (C-1), 1 (E-1) and 1 (F-1)].

9.17.4 Loadbreak Switch on Outgoing Circuit

Where loadbreak switch and power fuse are provided in each of the outgoing circuits, the outgoing circuit power fuse compartment door shall be interlocked with the switch [Refer to sketches 1 (B-1) to 1 (J-3)]. In installations incorporating Customer service power fuse, the Customer service power fuse compartment door shall be interlocked with the switch [Refer to sketches 1 (C-1), 1 (E-1), and 1 (F-1)].

9.17.5 Circuit Breaker on Outgoing Circuit

Where circuit breaker is provided in each of the outgoing circuits, the Customer service power fuse compartment door shall be interlocked with the downstream circuit breakers and the upstream Customer service loadbreak switch [Refer to sketch 1 (F-1)].

9.17.6 Customer Service Loadbreak Switch

The compartment door for Customer service power fuses shall be interlocked with the preceding switch [Refer to sketches 1 (C-1), 1 (E-1) and 1 (F-1)].

9.17.7 Marking of Interlock Keys

Interlock keys should have the inscriptions “KIRK TYPE INTERLOCKS DO NOT DUPLICATE”. Kirk type interlock key should be used.

9.17.8 Circuit Breaker Used Instead of Fuse

When a circuit breaker is used instead of a fuse ([Section 9.11](#)), circuit breaker to switch interlocks are not required where line side loadbreak switch is used [Refer to sketches 1 ([B-1](#)), and 1 ([D-1](#))]. All other interlocks to prevent feeder paralleling are required.

9.17.9 Fixed Type Circuit Breaker

When a non-withdrawable type circuit breaker is used as the Customer's first protective device, it shall be preceded by upstream loadbreak switch. Interlock between circuit breaker and a loadbreak switch shall not be required.

9.18 Grounding

9.18.1 Additional Grounding

In addition to grounding requirements as specified in the latest CSA Standard C22.2 No. 31, readily accessible ground connection shall be provided in each of the incoming line cable termination compartments and in the metering voltage transformer compartment.

9.18.2 Grounding Facilities

In order to comply with the Occupational Health and Safety Act, the following facilities for grounding the incoming feeder cable terminations must be provided:

- (a) A standard grounding stirrup [Refer to sketches 4 ([A-1](#)) and 4 ([B-1](#))] must be installed on the ground bus in each incoming feeder termination compartment, approximately 0.3 m inside the compartment door.
- (b) A standard grounding stirrup [Refer to sketches 4 ([A-1](#)) and 4 ([B-1](#))] must be installed on each phase conductor in each incoming feeder termination compartment.
- (c) Grounding using the 1-inch ball stud is also acceptable provided that the grounding cable is supplied and stored in a padlockable enclosure. This enclosure shall be supplied by the Customer and shall be located adjacent to the switchgear. The minimum size of ground cable is 3/0 extra flex copper. Each incoming termination cell requires a set of grounding cables.
- (d) Once in service, Toronto Hydro will padlock all grounding facilities on the incoming feeders and only Toronto Hydro personnel will be permitted to carry out grounding operations on incoming feeders.

9.18.3 Cable Compartment

The ground connection in the cable termination compartments shall be positioned at an easily accessible location to accommodate Toronto Hydro ground clamp.

When the incoming feeder termination is located at the upper compartment of the switchgear, a portable platform to facilitate the installation of grounds shall be provided.

The portable platform shall be a rolling type, dielectrically tested and CSA certified with the height adequate to access all top vertical components of the switchgear cell. Dimensions of the top platform step shall be no less than indicated in the [sketch 6](#).

Alternatively, a platform can be built from 19 mm plywood construction as per requirements of [sketch 6](#). Plywood platform shall be painted in gray.

Portable platforms shall be marked as per requirements of [sketch 6](#).

9.18.4 Voltage Transformer Compartment

The ground connection in the voltage transformer compartment shall be provided with two 10/24 tapped holes to connect metering equipment ground leads.

9.18.5 Metallic Parts

Throughout the equipment all non-current carrying metallic parts shall be bonded to the ground.

9.18.6 Ground Grid Connections

The switchgear assembly ground bus shall be connected to the substation ground grid at two ends with minimum 2/0 copper ground conductor.

9.19 Automatic Transfer between Normal and Standby Supply

9.19.1 Notification Requirements

If manual operation of the automatic transfer switch is required, Toronto Hydro must be advised in advance.

A typical automatic transfer scheme is shown on sketch 5 ([A-1](#)).

9.19.2 Automatic Transfer Functional Requirements

- (a) Under normal condition, the Normal breaker/switch is closed, and the Standby breaker/switch is open. Upon loss of the Normal supply, the Normal breaker (or loadbreak switch) shall open and the Standby breaker (or loadbreak switch) shall close. Automatic transfer shall be initiated only if the Standby supply is energized and lock out of the transfer scheme has not activated part (c) below.
- (b) After a successful transfer from Normal to Standby, the supply shall remain on the Standby feeder even after the normal feeder has been restored. Toronto Hydro shall manually switch the Customer back to Normal feeder. Automatic transfer back to the Normal feeder shall take place only in the event of power loss of the

Standby feeder, and provided the Normal feeder is energized. An adjustable time delay (0 to 10 seconds range) shall be provided, before a transfer is initiated. This shall apply to both the transfers from Normal to Standby and from Standby to Normal feeders.

- (c) The equipment shall include suitable overcurrent protective devices to prevent a transfer in the event of a fault occurring on or downstream from the auto transfer circuit breakers (or loadbreak switches). In the event of an operation of these devices, the breaker must trip and the automatic transfer shall lock out, and shall remain locked-out until it is manually reset by Toronto Hydro. The lock-out device shall be key operated such that the key shall be retained by Toronto Hydro or, alternatively, a cover shall be placed over the device and locked with a Toronto Hydro padlock. The current transformers supplying the overcurrent devices shall be located on the line side of the circuit breakers (or loadbreak switches).
- (d) An Auto-Manual selector switch shall be provided, and the manual control of individual supply circuit breakers (or loadbreak switches) shall only be possible with the selector switch in the Manual position.
- (e) The control switches of each breaker (or loadbreak switch) shall be connected such that a Customer may manually transfer from Normal to Standby and from Standby to Normal by first tripping the supply breaker (or loadbreak switch), and then closing the Standby (or Normal) breaker (or loadbreak switch). The paralleling of the incoming feeders by the Customer is not permitted.
- (f) A key operated “Toronto Hydro Interlock” switch, with one key only for Toronto Hydro use shall be provided. The key shall remain trapped in the lock when the interlock circuit is in the “By-Pass” position. This is to permit the paralleling of feeders by Toronto Hydro.
- (g) Indication lights conforming to the following Toronto Hydro standard shall all be provided:

RED	To indicate Breaker Closed
GREEN	To indicate Breaker Open
WHITE	A normally closed breaker has tripped and is now open.
BLUE	Potential Indication
YELLOW/AMBER	Lockout operation.

- (h) Motorized loadbreak switches shall be equipped with a positive means, acceptable to Toronto Hydro, of making them inoperative when in the open position. This is to provide safe conditions when Toronto Hydro is making repairs or conducting tests.

- (i) Voltage sensing transformers shall be arranged such that they can be easily disconnected from the feeder cables and locked in the disconnected position. This is to provide safe conditions when Toronto Hydro is making repairs or conducting tests on the feeder cables.
- (j) Circuit breakers or loadbreak switches shall be equipped with an operation counter.
- (k) Potential indication lights shall be provided for each ATS potential transformer associated with each incoming feeder.

9.20 Emergency Backup and Embedded Generation Facilities

Emergency Backup and Embedded Generation shall comply with the requirements of “Toronto Hydro Distributed Generation Requirements” document, [Section 6 - Reference document of the Conditions of Service].

9.21 Line Differential Relay Protection

Line differential relay protection arrangement is provided at the sole discretion of Toronto Hydro. Additional conditions and costs may apply.

9.21.1 Toronto Hydro Scope of Supply

Where line differential (pilot-wire) relay protection or remote circuit breaker tripping is required, Toronto Hydro will provide a control cabinet or rack panel with line differential relays to communicate with the Toronto Hydro substation feeder relays via single-mode fiber optic cable.

9.21.2 Customer Scope of Supply

In order to support implementation of line differential (pilot-wire) relay protection, Customer shall provide the following:

- a) A dedicated 125 V DC voltage supply directly fed from DC distribution panel board or battery/charger unit via a dedicated double pole, pad-lockable 15A circuit breaker for the Toronto Hydro protection control circuit.
- b) A minimum 2 x 2 meter wall space for the Toronto Hydro protection and control cabinet or rack (the cabinet or rack may be wall-mounted or stand-alone). This allocated space should be in close proximity to the main incoming cells, accompanied by at least one 115 V AC receptacle at this vicinity. There shall be no unit heaters on the wall within above mentioned space.
- c) 2 - 1 ¼” underground PVC conduits per each incoming cell, one end stubbed up and into the main incoming circuit breaker control compartment and the other end stubbed up at the Toronto Hydro 2 x 2 meter wall space that is reserved for the Toronto Hydro protection and control cabinet or rack.

- d) At the location of the high voltage duct bank at the high voltage electrical room, there shall be a 12"x12"x4" junction box at the vicinity of the duct bank (to run fiber cables) and a 2 ½" conduit shall be installed for fiber optic cable from the junction box/duct bank to the IT patch panel that will be located at or at the vicinity of the 2 x 2 meter wall space, coordinate with Toronto Hydro department prior to the installation for exact locations. Conduits shall enter and exit the top side of the junction box only.
- e) A dedicated main incoming CT per each incoming cell, at 1200:5, and have a tap for 800:5 ratio, for the purpose of Toronto Hydro line differential protection (87L).
- f) Switchgear DC schematics and wiring diagram, indicating the dedicated terminal blocks (#24-6 wire size) for wiring to at least one spare "a" and one spare "b" dry MOC contacts per incoming breaker, as well as dedicated terminal blocks that wire to the breaker trip coil, per each incoming cell.
- g) AC schematics and wiring diagram, indicating the dedicated double screw type terminal blocks (#20-6 wire size) for Toronto Hydro's connection to the dedicated CT, which shows the CT polarity, accuracy class, and ratio.

9.22 Test Blocks

Test blocks shall be installed in the current transformer secondary circuits on the relay panel for each set of protective relays to permit the disconnection of the protective relays and to short circuit the current transformer secondary circuit for test purposes.

9.23 Annunciation – SF6 Low Pressure

- (a) Each SF6 circuit breaker or any SF6 compartment within the electrical room shall have a gauge to monitor the low SF6 pressure installed within the circuit breaker or SF6 compartment.
- (b) A warning light shall be provided on the control panel of each SF6 circuit breaker or any SF6 compartment to indicate "Low SF6 Gas Pressure".
- (c) A "Lamp Test" button shall be installed on the control panel of each individual circuit breaker or SF6 compartment for testing the individual warning light.
- (d) A sign stating "Low SF6 Gas Pressure" shall be mounted above each warning light.
- (e) The low pressure warning lights shall be simultaneously activated with the external light(s) as indicated in [Section 8.9](#).

9.24 Protective Relays

9.24.1 Relay Settings

Relays that are under Toronto Hydro's operating jurisdiction shall have provisions for Toronto Hydro seals to prevent unauthorized change of relay settings.

9.24.2 Current Transformer Secondary Wiring

The size of all current transformer secondary wiring shall be #10 AWG.

9.24.3 Protection of Cable Tie

Dedicated protection device for cable tie is optional if cable is adequately protected by upstream protective device. Rating of cable tie shall be in compliance with requirements of Table 2.

9.25 Faulted Circuit Indicators

Toronto Hydro shall provide faulted circuit indicators (FCI) for each phase of incoming feeders.

Customer shall provide provision for FCI installation inside of the switchgear compartment where Toronto Hydro incoming feeders are terminated. FCI status shall be visible through provided safety window.

9.26 Transformers

To coordinate with Toronto Hydro upstream protective devices, Customer’s transformers shall be restricted to the ratings shown in Table 4. Protection and connection of Customer-Owned Substations to the Toronto Hydro distribution system shall be as per the guidelines shown in Table 5.

Table 4 - Customer Transformer Ratings and Winding Configurations

Toronto Hydro Supply Station	Single Transformer Nominal MVA Rating	Transformer Primary-Secondary Winding Configuration	BIL Rating
27.6 kV Terminal Station	Less than 3 MVA*	$Y_G - Y_G$	Refer to Section 9.1
	3 MVA *** or greater (maximum 10 MVA)	$\Delta - Y_G$	Refer to Section 9.1
13.8 kV Terminal Station**	Up to 7.5 MVA	$\Delta - Y_G$	Refer to Section 9.1

* Where winding configurations are required that differ from the above table, requests shall be submitted to systemstudies@torontohydro.com for analysis and review. For transformer windings with YG - YG configuration, a 5 legged transformer core shall be used.

** For 13.8 kV Municipal Station connections, a request shall be submitted to Toronto Hydro for review.

*** For substations where at least one of transformers nominal MVA is 3 MVA or greater any additional transformers may also have winding configuration as $\Delta - Y_G$.

9.27 Arc Flash Warning Signs

The arc flash warning sign shall be attached to the exterior door of each compartment of Customer-Owned High-Voltage Switchgear.

Arc flash warning signs shall be printed on 4"x6" self-adhesive vinyl tape suitable for both indoor and outdoor environments and contain information shown in [sketch 8](#).

9.28 Re-used, Refurbished or Modified High-Voltage Equipment

When previously used, refurbished or modified by a third party equipment is deployed for Customer-Owned Substations it shall meet the following requirements:

9.28.1 Switchgears

- a) Switchgears shall be evaluated by authorized agency or original equipment manufacturer to confirm its compliance with applicable CSA standards. Certificate of compliance with CSA standards shall be submitted to Toronto Hydro for review and approval.
- b) Switchgears shall be tested as per latest NETA specifications. Evidence of successful testing shall be submitted to Toronto Hydro for review and approval.

9.28.2 Transformers

- a) Transformers shall be tested and inspected as per latest NETA specifications.
- b) Insulation liquid tests shall be performed for liquid filled transformers in accordance with the latest NETA specifications. Evidence of successful testing shall be submitted to Toronto Hydro for review and approval.

Table 5 - Guidelines for Customer-Owned Substation Protection and Connections ⁽⁷⁾ to Distribution System

Toronto Hydro Distribution System						Customer Requirements	
Distribution System (Supply Station)	Feeder Connection		Primary Cable Size		Lateral	Customer-Owned Substation	
	Main	Lateral Fuse Rating (Amps)			Aggregate Transformer MVA	Maximum Single Transformer MVA ⁽⁸⁾	Maximum Fuse Rating
			Underground	Overhead			
27.6 kV Terminal Station	-	140 K	1/0 Al, TRXLPE, 1C ⁽⁶⁾	3/0 AWG (ACSR), Al	≤ 9	3	80 E
	-	200 K ⁽¹⁾	1/0 Cu, TRXLPE, 1C ⁽⁶⁾	3/0 AWG (ACSR), Al	≤ 11	5	125 E
	(2)	-	1000 kcmil Al, TRXLPE, 1C	556.5 kcmil (ASC), Al	-	10 ⁽⁵⁾	circuit breaker (Refer to section 9.11)
13.8 kV Terminal Station	-	140 K ⁽⁴⁾	3/0 Cu, TRXLPE, Triplex	3/0 AWG (ACSR), Al	≤ 5	1.5	80 E
	(3)	-	3/0 Cu, TRXLPE, Triplex	-	-	5 ⁽⁵⁾	circuit breaker (Refer to section 9.11)
			500 kcmil Cu, TRXLPE, Triplex			7.5 ⁽⁵⁾	
13.8 kV Municipal Station	-	100 K	1/0 Al, TRXLPE, 1C	3/0 AWG (ACSR), Al	≤ 3	1.0	65 E

Notes:

- (1) Contact systemstudies@torontohydro.com to confirm coordination with the feeder’s circuit breaker at the terminal station.
- (2) Overhead or pad-mounted type SCADA-operated three-phase gang operated loadbreak switch to be used for connection to the main feeder.
- (3) Connect directly to the main underground feeder.
- (4) Applies to overhead only (i.e. fuses at pole).
- (5) For multiple transformer units, contact systemstudies@torontohydro.com for capacity confirmation.
- (6) Cable rating is based on 80% load diversity factor.
- (7) Three-phase Customer-Owned Substations shall not be connected within a feeder loop where there is a single-phase Customer connected to one of the feeder phases.
- (8) In addition, where more than one transformer is connected, the Customer’s aggregate transformers MVA can not exceed the values as specified in the column.

10. METERING REQUIREMENTS

For metering requirements, refer to the “Toronto Hydro Metering Requirements for 13.8 kV & 27.6 kV Customer-Owned Substations” document, [Section 6 - Reference document of the Conditions of Service].

11. ASSOCIATED PUBLICATIONS

The latest revisions of the Publication listed below shall apply. In case of conflict between the Publications below and Toronto Hydro requirements, the latter will govern.

Canadian Standards Association (CSA):

- C22.2 No. 31** Switchgear Assemblies
- C22.2 No. 94** Special Purpose Enclosures 2, 3, 4 and 5
- C22/2 No. 193** High Voltage Full-load Interrupter Switches
- CAN 3-C13** Instrument Transformers

Electrical and Electronic Manufacturers Association of Canada (EEMAC):

- G8-3.2** Metal Clad and Station-type Switchgear
- G10-1** Revenue Metering Equipment in Switchgear Assemblies

Institute of Electrical and Electronic Engineers (IEEE):

- Std 48** Test Procedures and Requirements for High Voltage ac Cable Terminations
- C37.74** Standard Requirements for Subsurface, Vault, and Padmounted Load-Interrupter Switchgear and Fused Load-Interrupter Switchgear for Alternating Current Systems up to 38 kV
- 386** Standard for Separable Insulated Connector Systems for Power Distribution Systems above 600 V
- Std 80** Outdoor Grounding Requirements
- C37.20.2 – 2022** IEEE Standard for Metal-Clad Switchgear
- C57.12.28** IEEE Standard for Pad-Mounted Equipment-Enclosure Integrity

American National Standards Institute (ANSI):
C37 series of Standards

NETA – Standard for Acceptance Testing Specification for Electrical Power Equipment and System

National Electrical Manufacturers Association (NEMA)

12. SKETCHES

<u>Sketch 1 (A-1)</u>	Typical Single Line Diagram Legend
<u>Sketch 1 (B-1)</u>	Incoming Circuit: Loadbreak Switch One Outgoing Circuit: Fuse
<u>Sketch 1 (C-1)</u>	Incoming Circuit: Loadbreak Switch Outgoing Circuits: Loadbreak Switches and Fuses
<u>Sketch 1 (C-2)</u>	Incoming Circuit: Loadbreak Switches and Breakers Outgoing Circuits: Loadbreak Switches and Fuses
<u>Sketch 1 (D-1)</u>	Incoming Circuits: Loadbreak Switches One Outgoing Circuit: Loadbreak Switch and Fuse
<u>Sketch 1 (E-1)</u>	Incoming Circuits: Loadbreak Switches Outgoing Circuits: Loadbreak Switches and Fuses
<u>Sketch 1 (E-2)</u>	Incoming Circuits: Loadbreak Switches and Breaker Outgoing Circuits: Loadbreak Switches and Fuses
<u>Sketch 1 (F-1)</u>	Incoming Circuits: Loadbreak Switches Outgoing Circuits: Circuit Breakers
<u>Sketch 1 (F-2)</u>	Incoming Circuits: Loadbreak Switches and Breaker Outgoing Circuits: Circuit Breakers
<u>Sketch 1 (G-1)</u>	Incoming Circuits: Circuit Breakers Outgoing Circuits: Loadbreak Switches and Fuses
<u>Sketch 1(H-1)</u>	Incoming Circuits: Circuit Breakers (Split-Bus) Outgoing Circuits: Loadbreak Switches and Fuses
<u>Sketch 1 (H-2)</u>	Dedicated Incoming Circuits: Circuit Breakers (Split-Bus) Outgoing Circuits: Circuit Breakers
<u>Sketch 1 (I-1)</u>	Incoming Circuits: Pilot Wire Protected Circuit Breakers Outgoing Circuits: Circuit Breakers
<u>Sketch 1 (J-1)</u>	Two Incoming Circuits with Remote Restoration For Peak Loads From 9 MVA to 13.3 MVA

- [Sketch 1 \(J-2\)](#) Two Incoming Circuits with Remote Restoration
For Peak Loads Below 9 MVA
- [Sketch 1 \(J-3\)](#) Two Incoming Circuits with Local Restoration
For Peak Loads Below 9 MVA
- [Sketch 2](#) Toronto Hydro Incoming Feeder Terminations
- [Sketch 3](#) Pothead Mounting Plates and Gasket Standard
(For Top Entry Termination)
- [Sketch 4 \(A-1\)](#) Grounding Stirrup Angled
- [Sketch 4 \(B-1\)](#) Grounding Stirrup Straight
- [Sketch 5 \(A-1\)](#) Typical Automatic Load Transfer Schematic
- [Sketch 6](#) Toronto Hydro Work Platform
- [Sketch 7](#) Arc Flash Sign





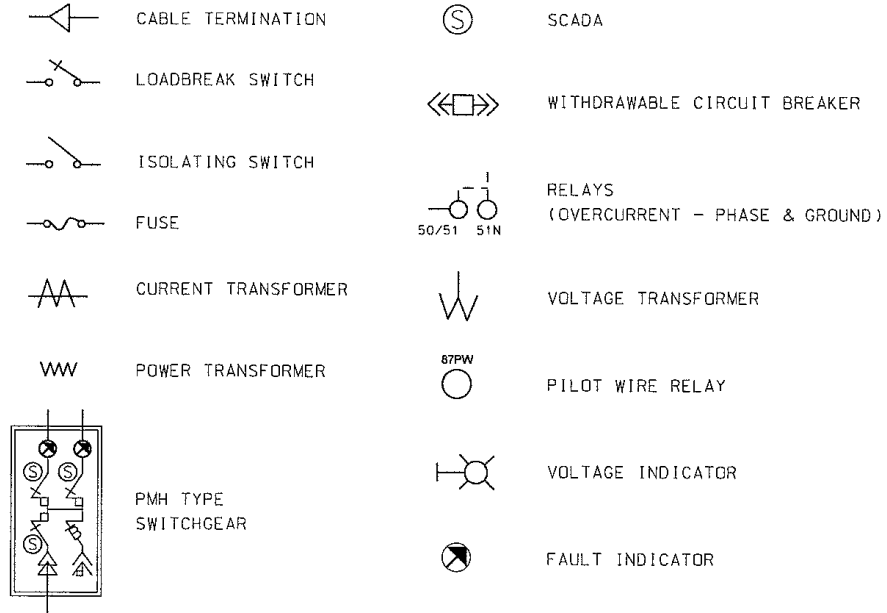

Table 6 - Sketches Applicability Matrix

Sketch #	13.8 kV			27.6 kV		
	1 feeder supply	2 feeders supply	Dedicated feeder supply	1 feeder supply	2 feeders supply	Dedicated feeder supply
Sketch 1 (B-1)	X			X		
Sketch 1 (C-1)	X			X		
Sketch 1 (C-2)	X			X		
Sketch 1 (D-1)		X				
Sketch 1 (E-1)		X				
Sketch 1 (E-2)		X				
Sketch 1 (F-1)		X				
Sketch 1 (F-2)		X				
Sketch 1 (G-1)		X				
Sketch 1 (H-1)		X < 8 MVA			X < 18 MVA	
Sketch 1 (H-2)						X 18 to 28 MVA 2 feeders
Sketch 1 (I-1)			X 8 to ≤ 40 MVA up to 5 feeders			
Sketch 1 (J-1)					X 9 to 13.3 MVA remote restoration	
Sketch 1 (J-2)				X	X < 9 MVA remote restoration	
Sketch 1 (J-3)				X	X < 9 MVA local restoration	
Sketch 5 (A-1)		X				

CIRCUIT COMPONENTS



INTERLOCKS

-  **A** MECHANISM LOCK:
KEY RELEASED WHEN SWITCH LOCKED OPEN
-  **B** MECHANISM LOCK:
KEY RELEASED WHEN BREAKER LOCKED OPEN
-  **C** MECHANISM LOCK:
KEY RELEASED WHEN SWITCH IN EITHER
FULLY OPEN OR FULLY CLOSED POSITION
-  **D** MECHANISM LOCK:
KEY RETAINED WHEN DOOR OPEN
-  NO. 2 KEY SHOWN IN LOCK
-  NO.2 KEY REMOVED FROM LOCK

SKETCH 1 (A-1)
TYPICAL SINGLE LINE DIAGRAM LEGEND

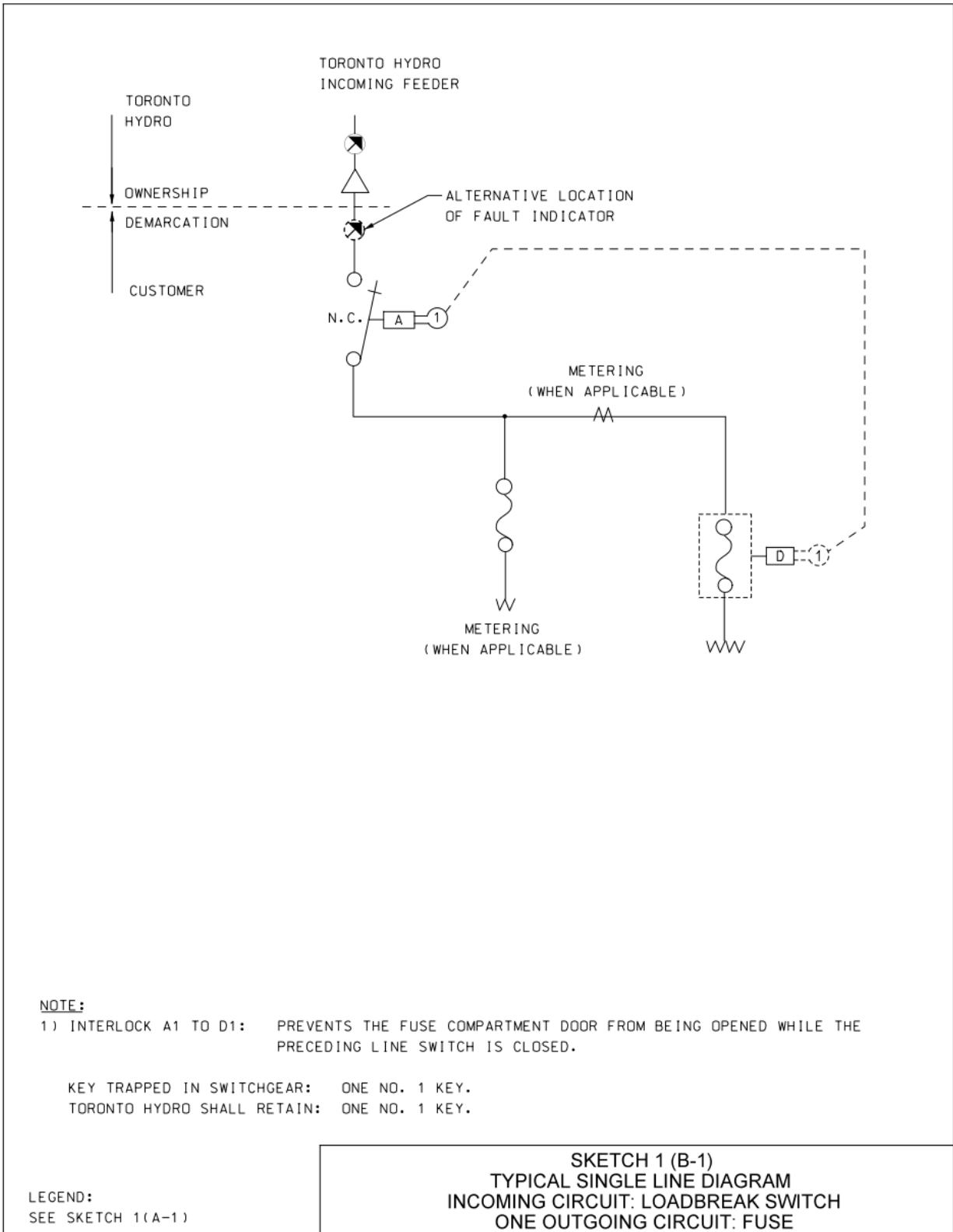

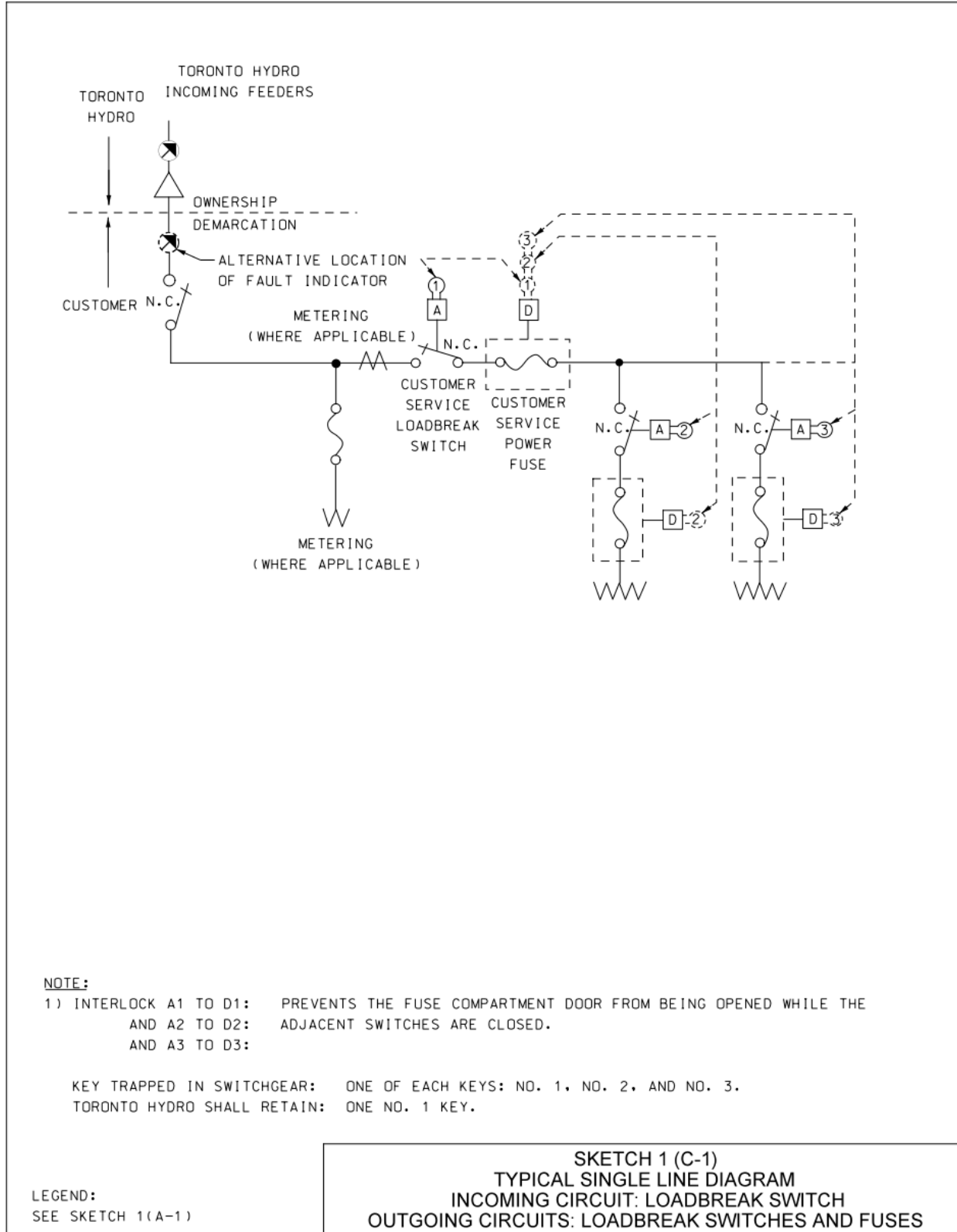

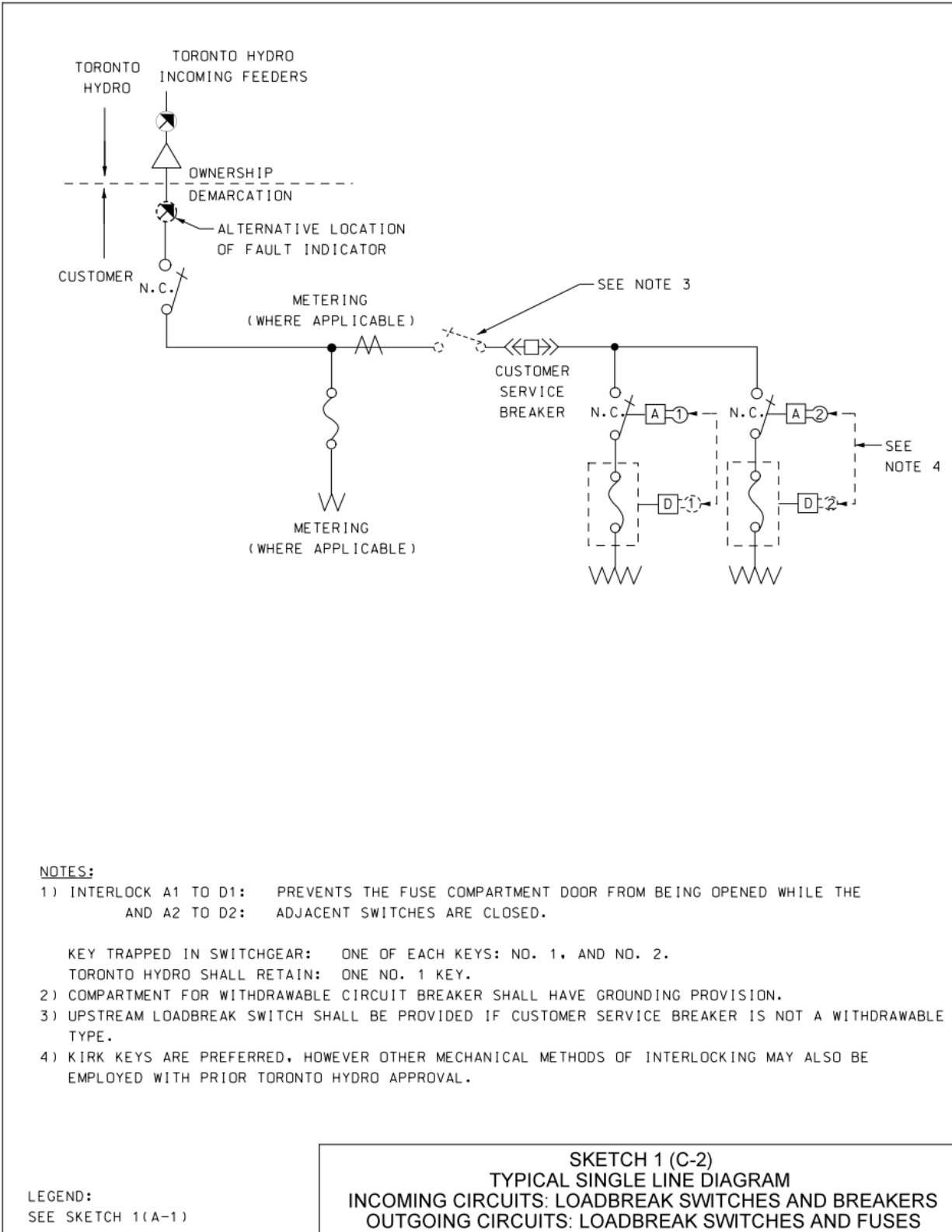

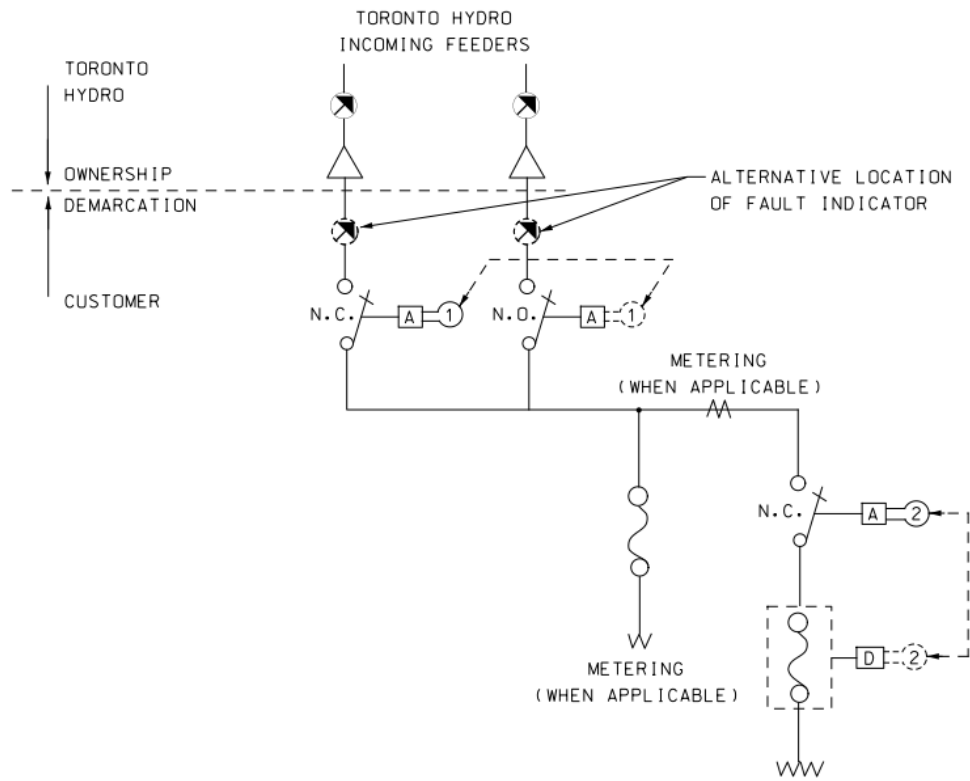

NOTES:

- 1) INTERLOCK A1 TO A1: PREVENTS THE INCOMING LINES FROM BEING PARALLELED BY THE CUSTOMER.
- INTERLOCK A2 TO D2: PREVENTS THE FUSE COMPARTMENT DOOR FROM BEING OPENED WHILE THE PRECEDING SWITCH IS CLOSED.

KEY TRAPPED IN SWITCHGEAR: ONE OF EACH KEYS: NO. 1, AND NO. 2.

TORONTO HYDRO SHALL RETAIN: TWO NO. 1 KEYS.

- 2) KIRK KEYS SHALL BE EMPLOYED FOR INCOMING LOADBREAK SWITCHES. FOR DOWNSTREAM SWITCH-FUSE COMBINATIONS, KIRK KEYS ARE ALSO PREFERRED, HOWEVER OTHER MECHANICAL METHODS OF INTERLOCKING MAY ALSO BE EMPLOYED WITH PRIOR TORONTO HYDRO APPROVAL.
- 3) THIS SKETCH IS ONLY APPLICABLE FOR 13.8 KV DUAL RADIAL SYSTEM.

LEGEND:
SEE SKETCH 1(A-1)

SKETCH 1 (D-1)
TYPICAL SINGLE LINE DIAGRAM
INCOMING CIRCUITS: LOADBREAK SWITCHES
ONE OUTGOING CIRCUIT: LOADBREAK SWITCH AND FUSE

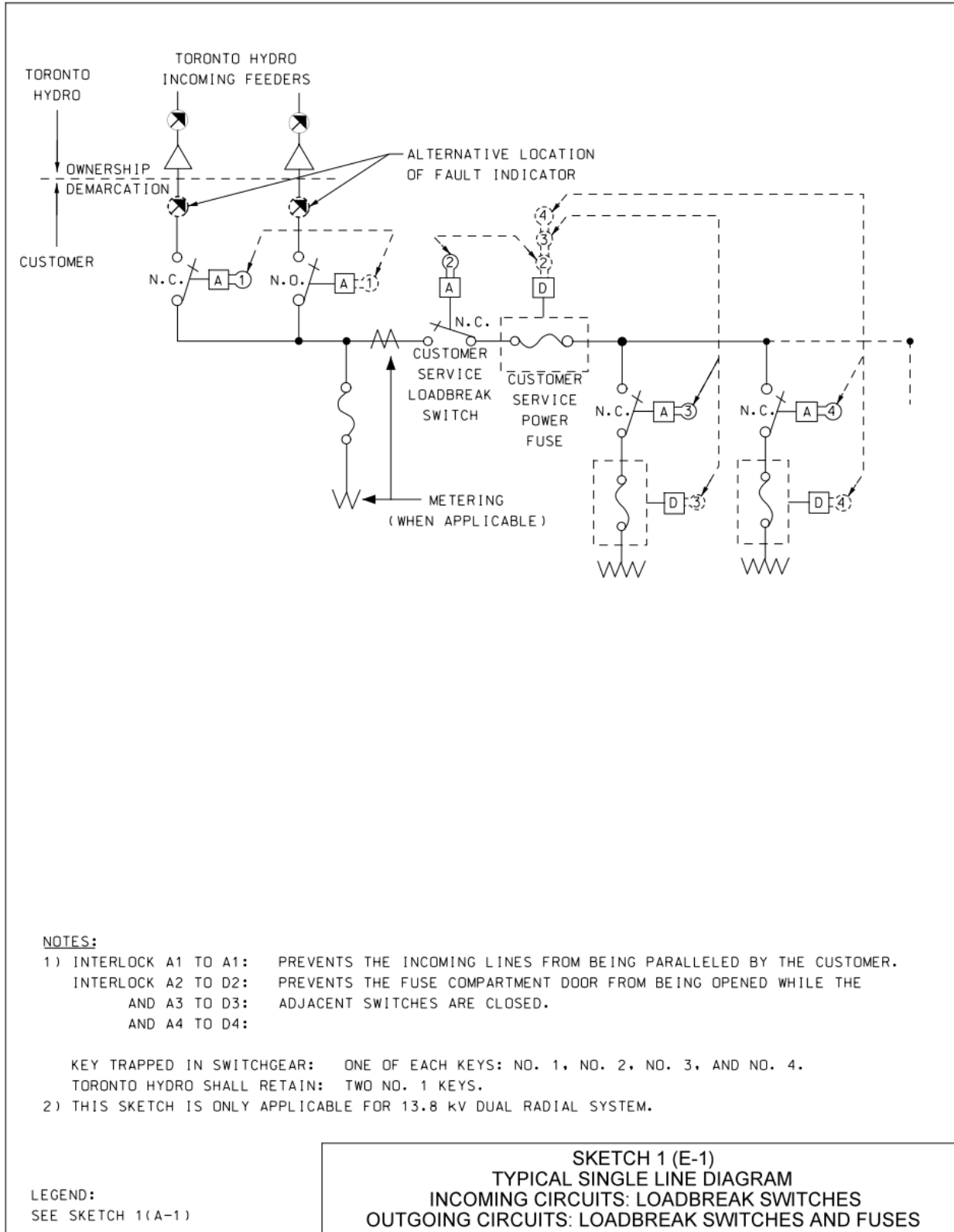

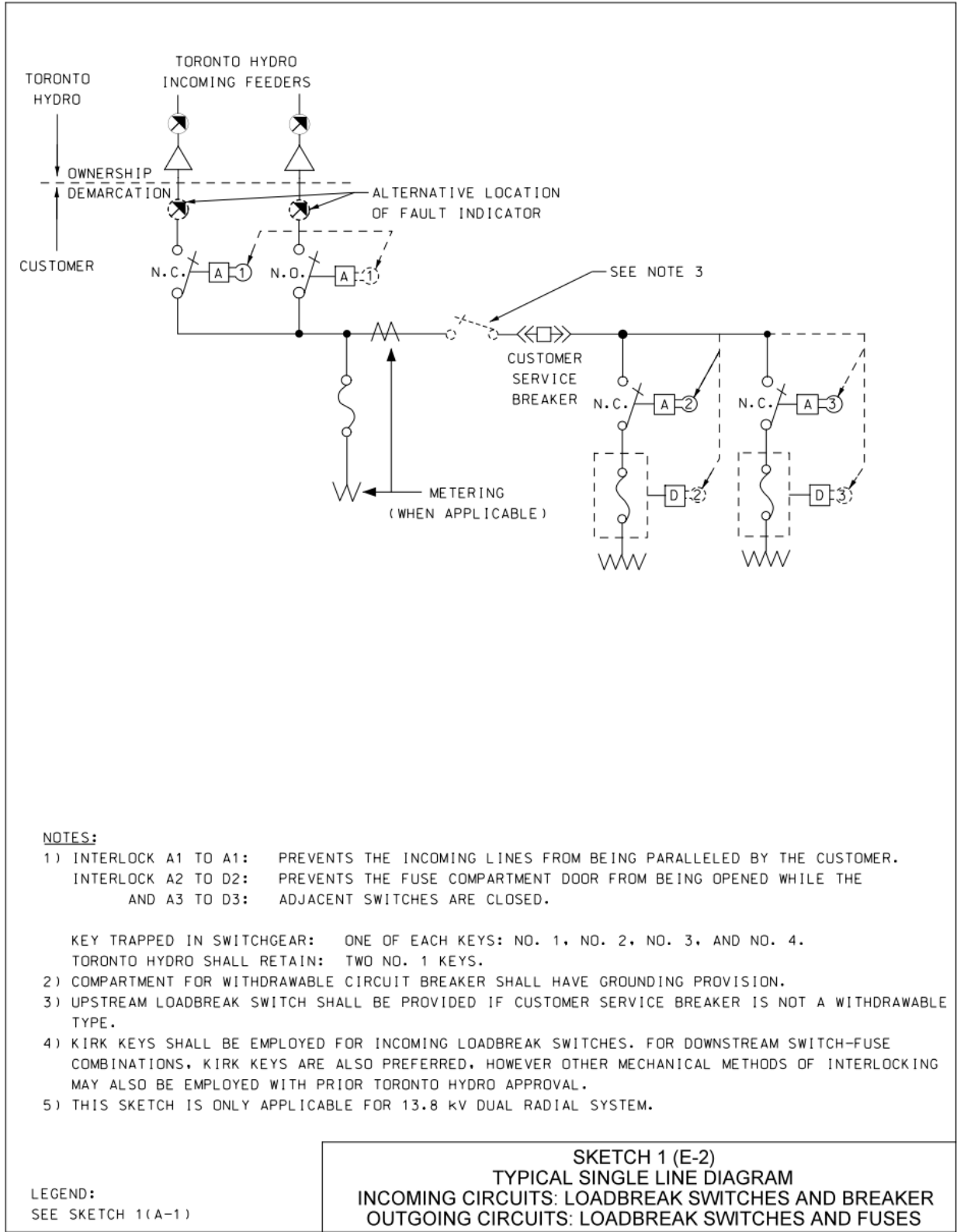

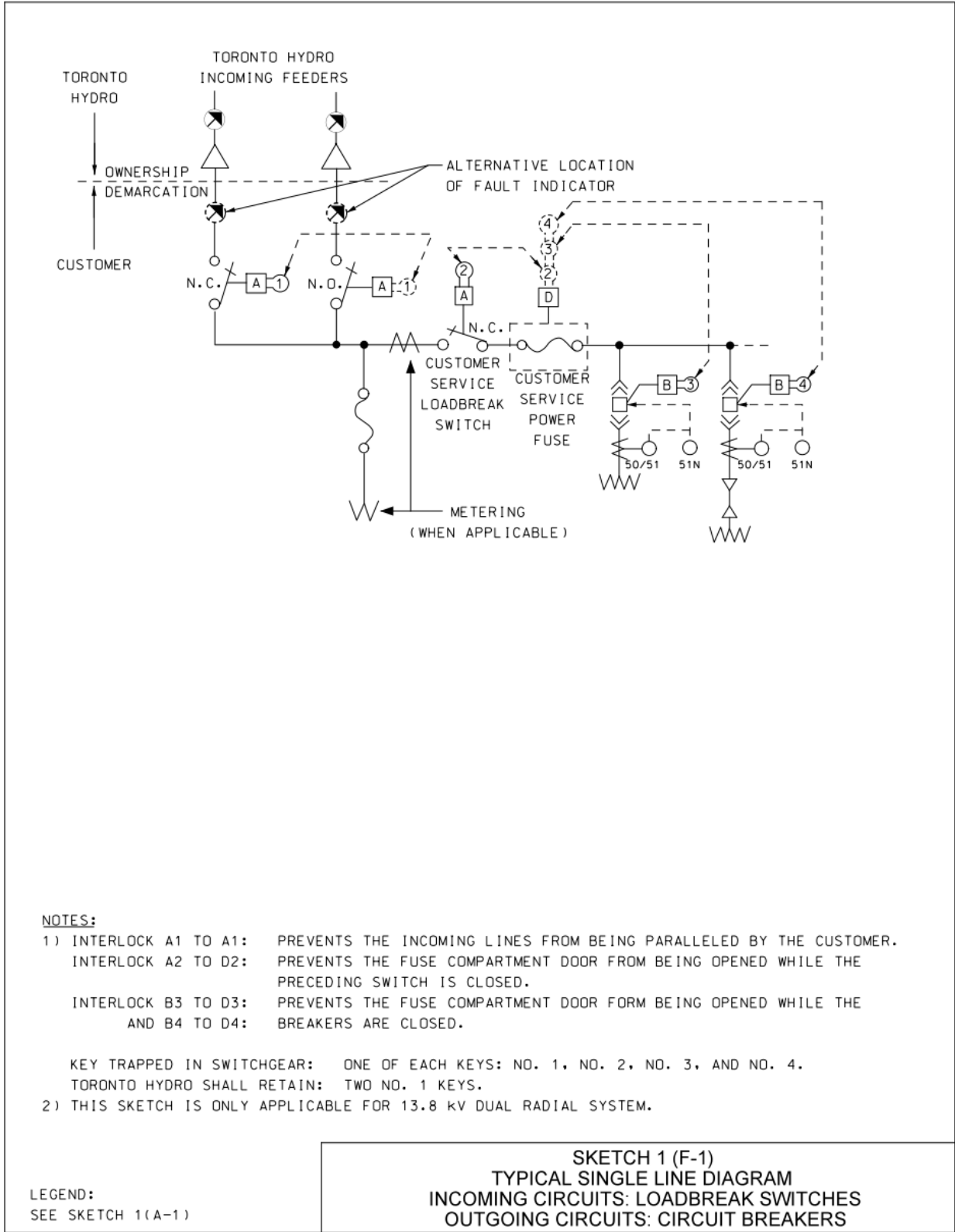

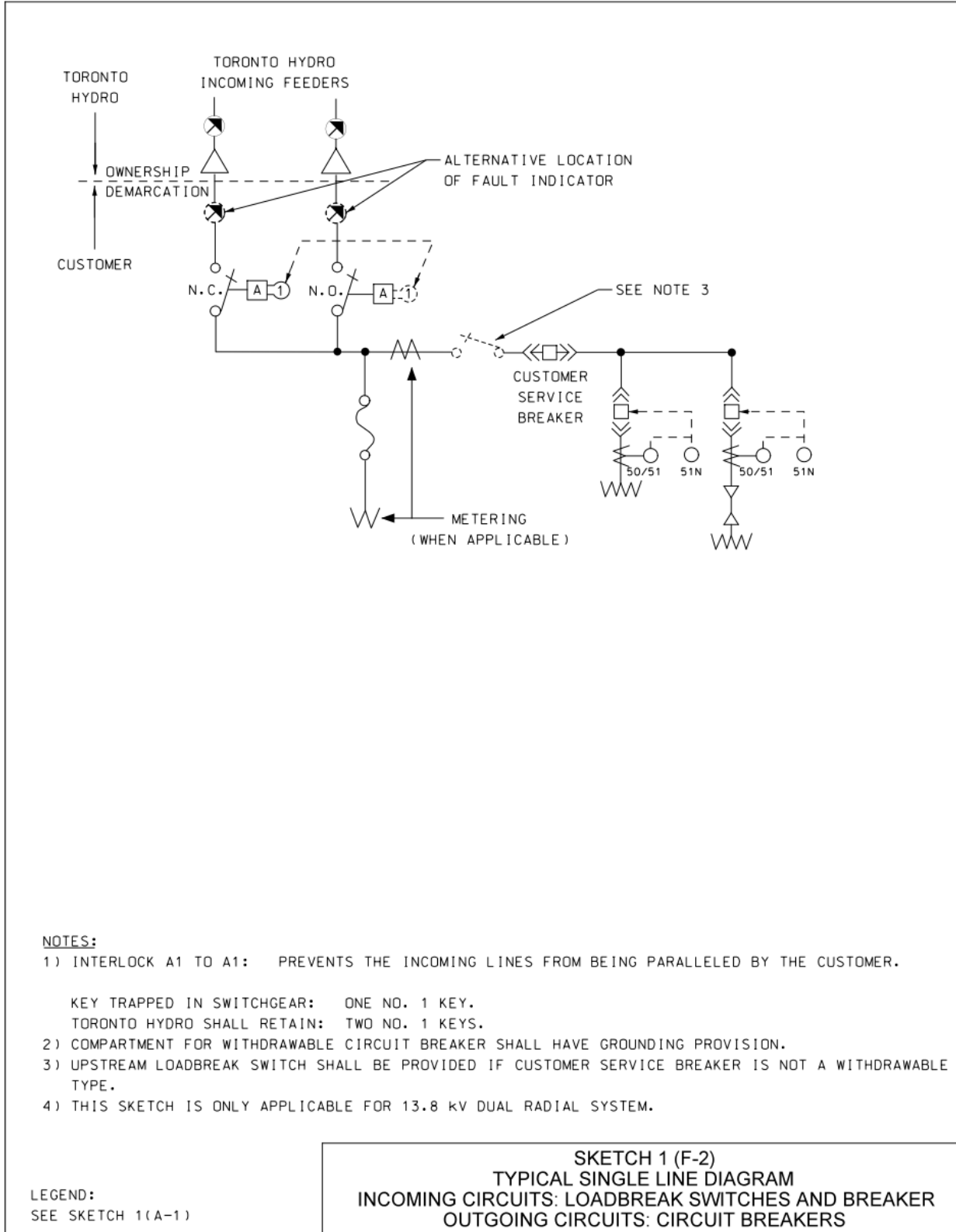

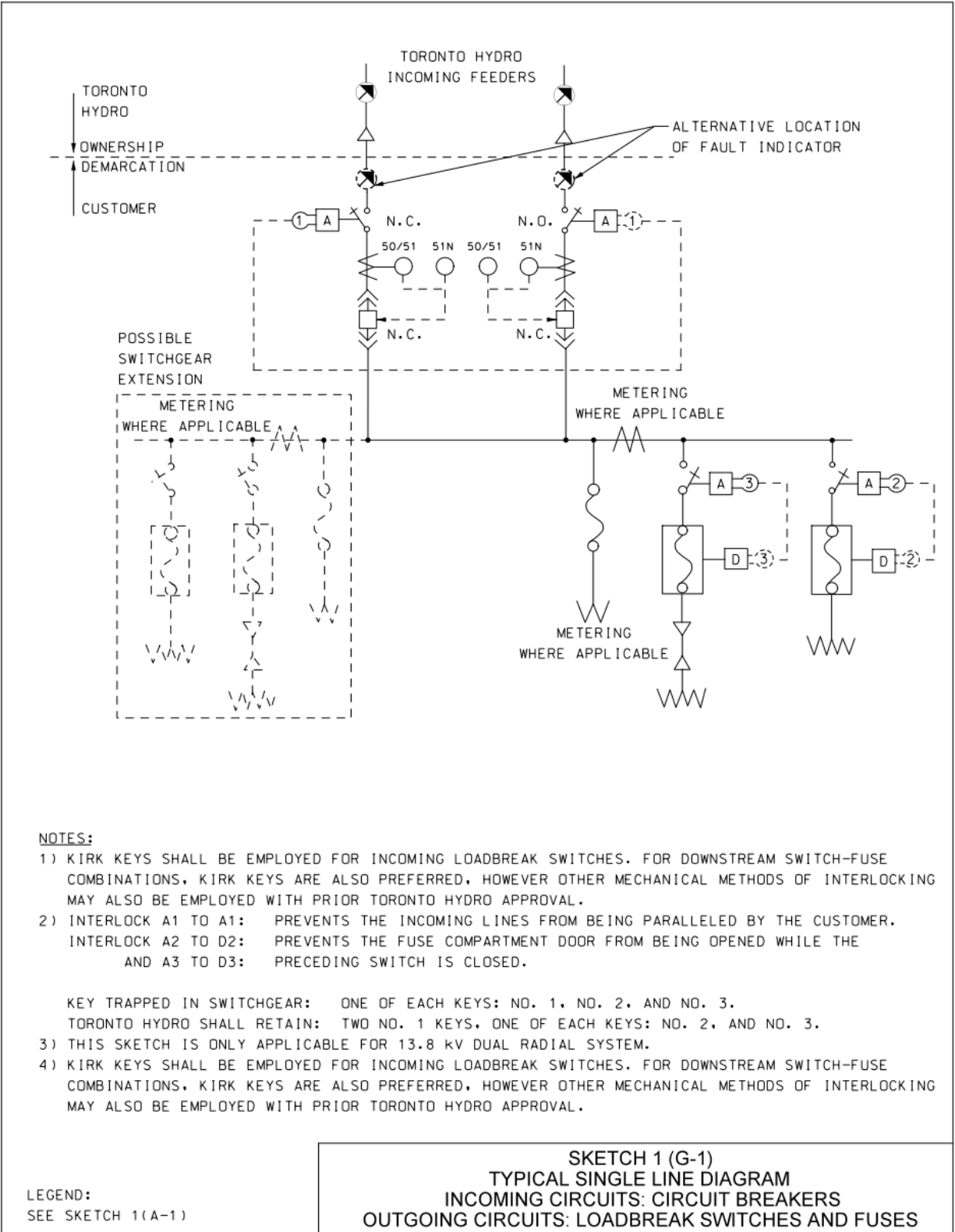

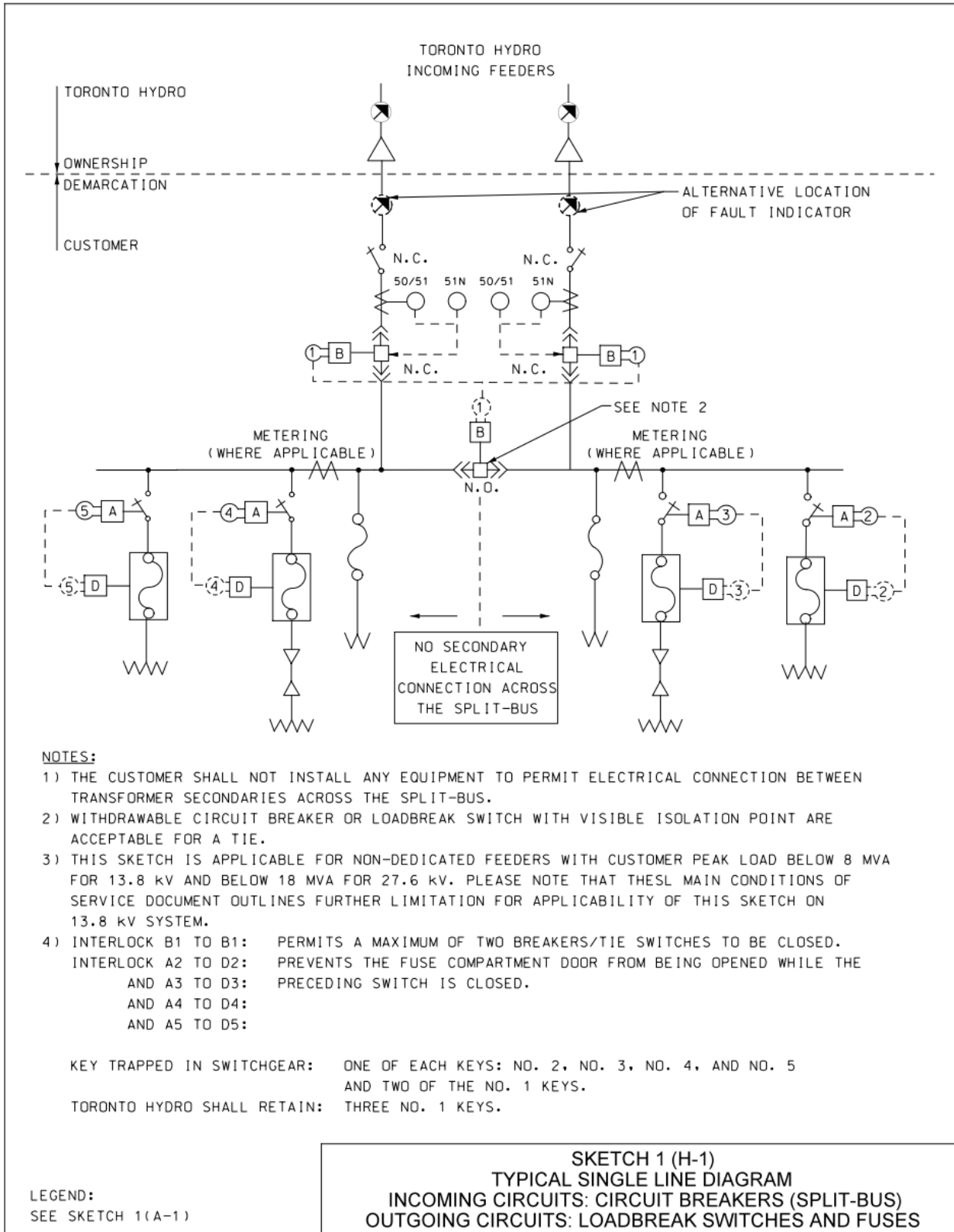

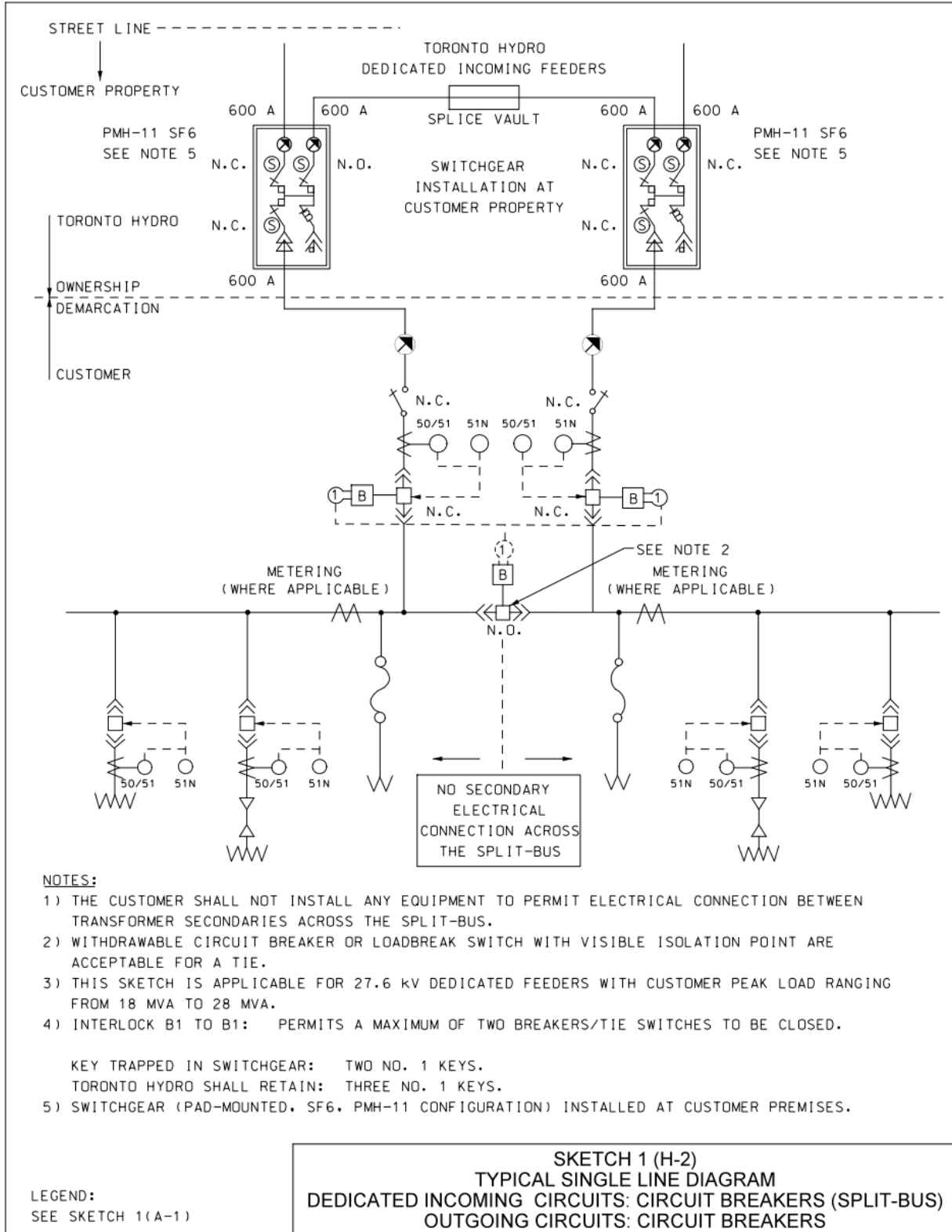

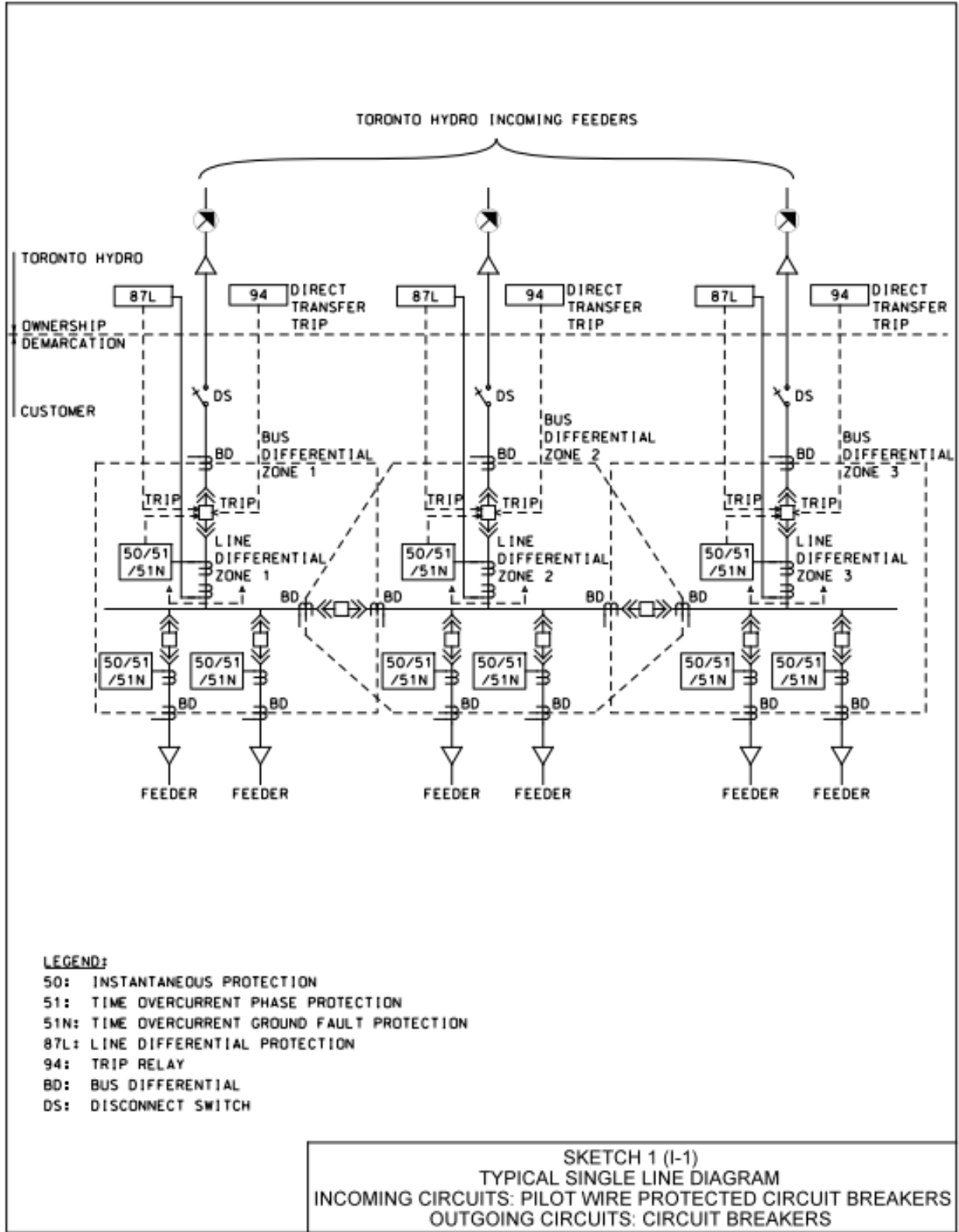

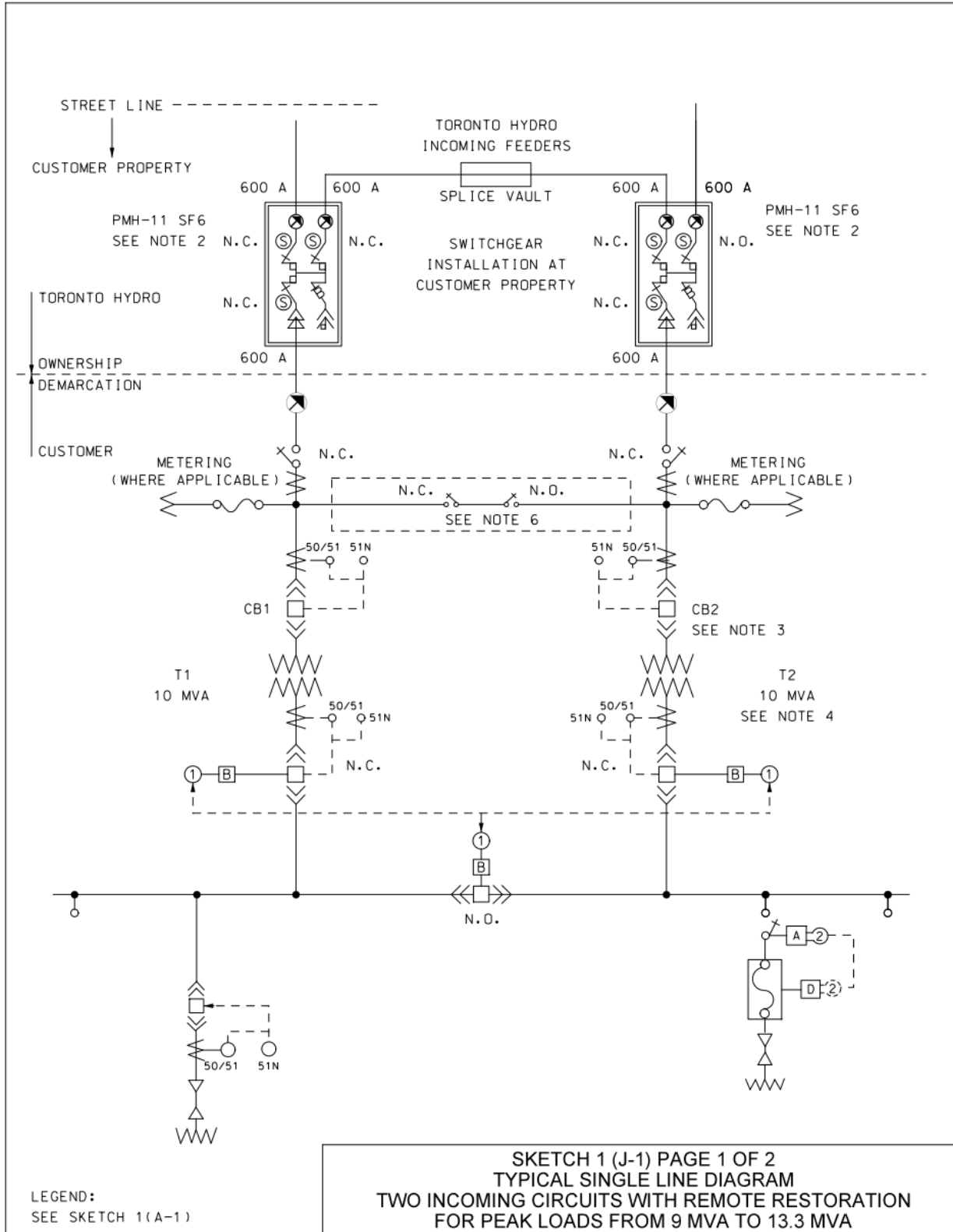

NOTES:

- 1) THIS SKETCH IS APPLICABLE FOR 27.6 KV SYSTEM WITH CUSTOMER PEAK LOAD RANGING FROM 9 MVA TO 13.3 MVA. CUSTOMER LOAD SHALL NOT EXCEED 13.3 MVA.
 - 2) SWITCHGEAR (PAD-MOUNTED, SF6, PMH-11 CONFIGURATION) INSTALLED AT CUSTOMER PREMISES.
 - 3) A TIME RELAY DELAY OF 1 SEC AFTER ENERGIZATION IS REQUIRED FOR CB2, WHERE AGGREGATE OF T1 AND T2 \geq 10 MVA.
 - 4) MAXIMUM TRANSFORMER SIZE SHALL BE LIMITED TO 10 MVA, ONAN.
 - 5) INTERLOCK A2 TO D2: PREVENTS THE FUSE COMPARTMENT DOOR FROM BEING OPENED WHILE THE PRECEDING SWITCH IS CLOSED.
INTERLOCK B1 TO B1: PERMITS A MAXIMUM OF TWO BREAKERS/TIE SWITCHES TO BE CLOSED.
- KEY TRAPPED IN SWITCHGEAR: TWO NO. 1 KEYS.
TORONTO HYDRO SHALL RETAIN: THREE NO. 1 KEYS.
- 6) THE TIE SWITCHES ARE OPTIONAL, HOWEVER THEIR IMPLEMENTATION WOULD OFFER A HIGHER AVAILABILITY AND FLEXIBILITY FOR THE CUSTOMER OWNED HIGH VOLTAGE SUBSTATION.

LEGEND:
SEE SKETCH 1(A-1)

SKETCH 1 (J-1) PAGE 2 OF 2
TYPICAL SINGLE LINE DIAGRAM
TWO INCOMING CIRCUITS WITH REMOTE RESTORATION
FOR PEAK LOADS FROM 9 MVA TO 13.3 MVA

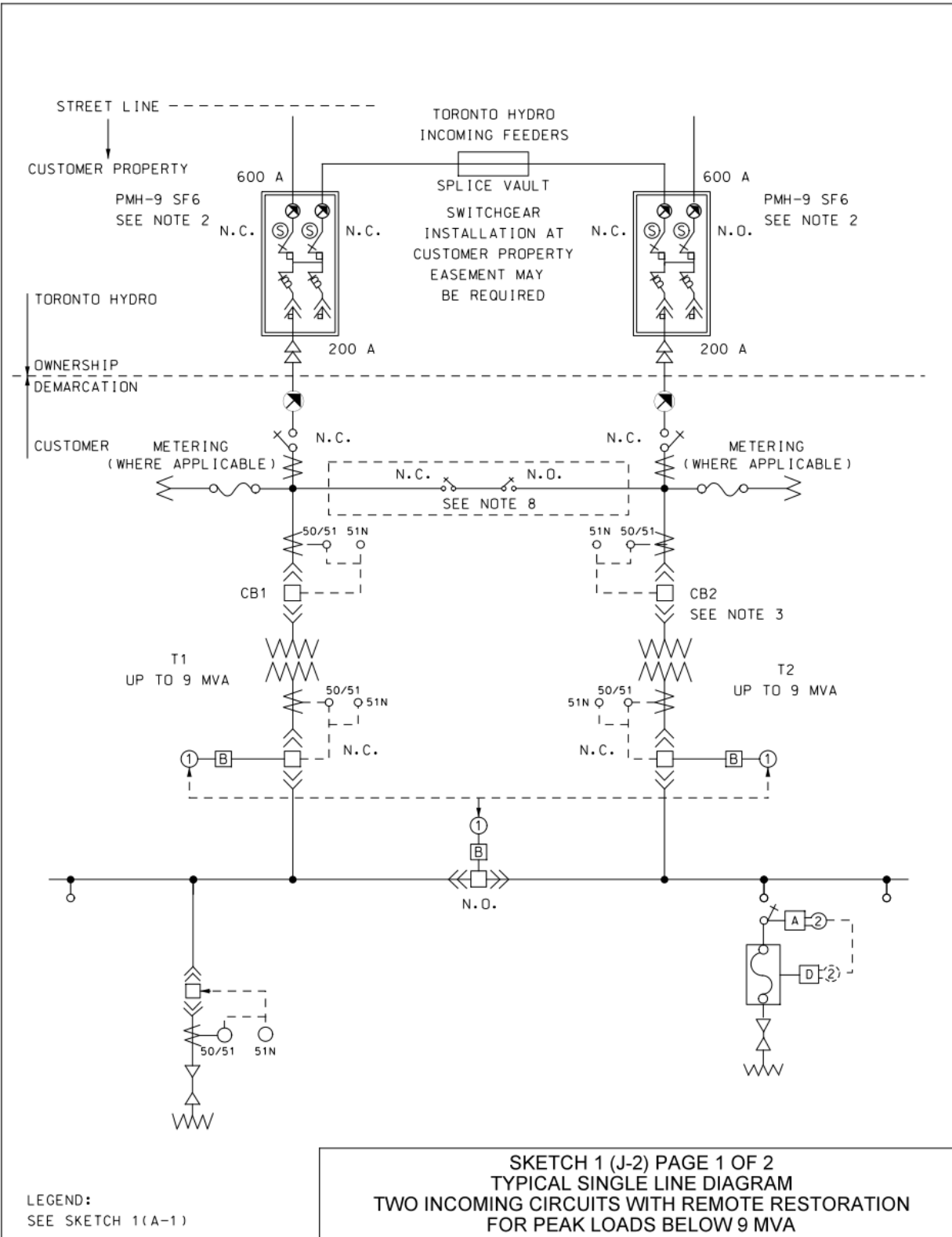

NOTES:

- 1) THIS SKETCH IS APPLICABLE FOR 27.6 KV SYSTEM WITH CUSTOMER PEAK LOAD BELOW 9 MVA. CUSTOMER LOAD SHALL NOT EXCEED 9 MVA.
- 2) SWITCHGEAR (PAD-MOUNTED, SF6, PMH-9 CONFIGURATION) INSTALLED AT CUSTOMER PREMISES.
- 3) A TIME RELAY DELAY OF 1 SEC AFTER ENERGIZATION IS REQUIRED FOR CB2, WHERE AGGREGATE OF T1 AND T2 \geq 10 MVA.
- 4) MAXIMUM TRANSFORMER SIZE SHALL BE LIMITED TO 9 MVA.
- 5) INCOMING FEEDERS MAY ORIGINATE FROM THE SAME STATION BREAKER.
- 6) INTERLOCK A2 TO D2: PREVENTS THE FUSE COMPARTMENT DOOR FROM BEING OPENED WHILE THE PRECEDING SWITCH IS CLOSED.
INTERLOCK B1 TO B1: PERMITS A MAXIMUM OF TWO BREAKERS/TIE SWITCHES TO BE CLOSED.

KEY TRAPPED IN SWITCHGEAR: TWO NO. 1 KEYS.

TORONTO HYDRO SHALL RETAIN: THREE NO. 1 KEYS.

- 7) KIRK KEYS SHALL BE EMPLOYED FOR INCOMING LOADBREAK SWITCHES. FOR DOWNSTREAM SWITCH-FUSE COMBINATIONS, KIRK KEYS ARE ALSO PREFERRED, HOWEVER OTHER MECHANICAL METHODS OF INTERLOCKING MAY ALSO BE EMPLOYED WITH PRIOR TORONTO HYDRO APPROVAL.
- 8) THE TIE SWITCHES ARE OPTIONAL, HOWEVER THEIR IMPLEMENTATION WOULD OFFER A HIGHER AVAILABILITY AND FLEXIBILITY FOR THE CUSTOMER OWNED HIGH VOLTAGE SUBSTATION.

LEGEND:
SEE SKETCH 1(A-1)

SKETCH 1 (J-2) PAGE 2 OF 2
TYPICAL SINGLE LINE DIAGRAM
TWO INCOMING CIRCUITS WITH REMOTE RESTORATION
FOR PEAK LOADS BELOW 9 MVA

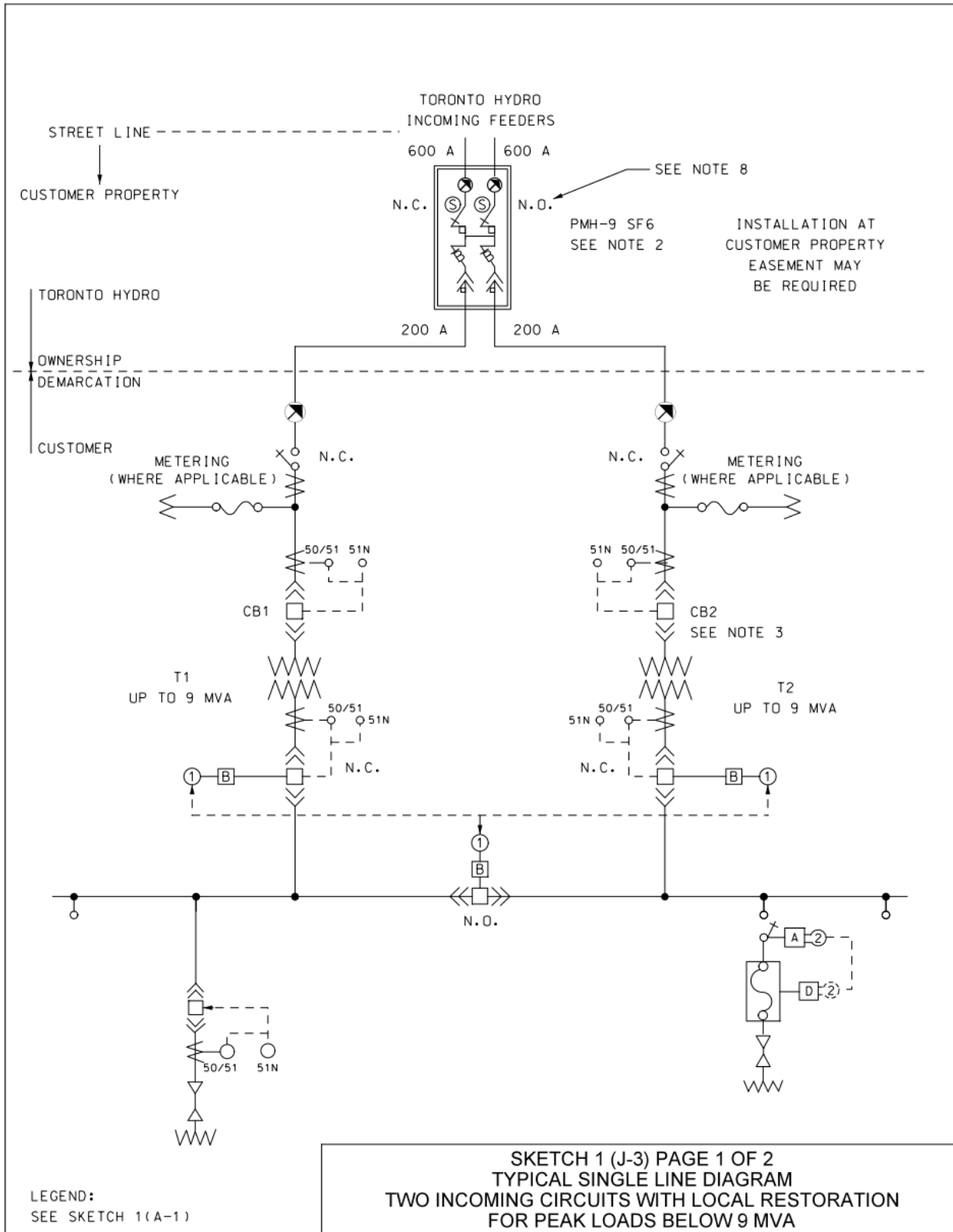

NOTES:

- 1) THIS SKETCH IS APPLICABLE FOR 27.6 KV SYSTEM WITH CUSTOMER PEAK LOAD BELOW 9 MVA. CUSTOMER LOAD SHALL NOT EXCEED 9 MVA.
- 2) SWITCHGEAR (PAD-MOUNTED, SF6, PMH-11 CONFIGURATION) INSTALLED AT CUSTOMER PREMISES.
- 3) A TIME RELAY DELAY OF 1 SEC AFTER ENERGIZATION IS REQUIRED FOR CB2, WHERE AGGREGATE OF T1 AND T2 \geq 10 MVA.
- 4) MAXIMUM TRANSFORMER SIZE SHALL BE LIMITED TO 9 MVA.
- 5) INCOMING FEEDERS MAY ORIGINATE FROM THE SAME STATION BREAKER.
- 6) REMOTE SWITCHING/RESTORATION WITH SCADA IS OPTIONAL FOR TRANSFORMER LESS THAN 5 MVA.
- 7) INTERLOCK A2 TO D2: PREVENTS THE FUSE COMPARTMENT DOOR FROM BEING OPENED WHILE THE PRECEDING SWITCH IS CLOSED.
INTERLOCK B1 TO B1: PERMITS A MAXIMUM OF TWO BREAKERS/TIE SWITCHES TO BE CLOSED.

KEY TRAPPED IN SWITCHGEAR: TWO NO. 1 KEYS.

TORONTO HYDRO SHALL RETAIN: THREE NO. 1 KEYS.

- 8) IF INCOMING FEEDER IS PART OF LOOP SUPPLY, THEN SWITCH STATUS SHALL BE N.C. AND EASEMENT WILL BE REQUIRED.
- 9) KIRK KEYS SHALL BE EMPLOYED FOR INCOMING LOADBREAK SWITCHES. FOR DOWNSTREAM SWITCH-FUSE COMBINATIONS, KIRK KEYS ARE ALSO PREFERRED, HOWEVER OTHER MECHANICAL METHODS OF INTERLOCKING MAY ALSO BE EMPLOYED WITH PRIOR TORONTO HYDRO APPROVAL.

LEGEND:
SEE SKETCH 1(A-1)

SKETCH 1 (J-3) PAGE 2 OF 2
TYPICAL SINGLE LINE DIAGRAM
TWO INCOMING CIRCUITS WITH LOCAL RESTORATION
FOR PEAK LOADS BELOW 9 MVA

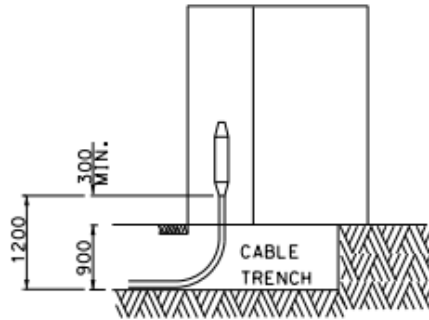

FIGURE 1

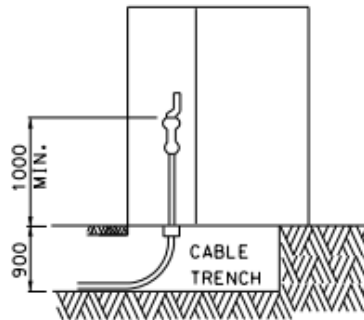

FIGURE 2

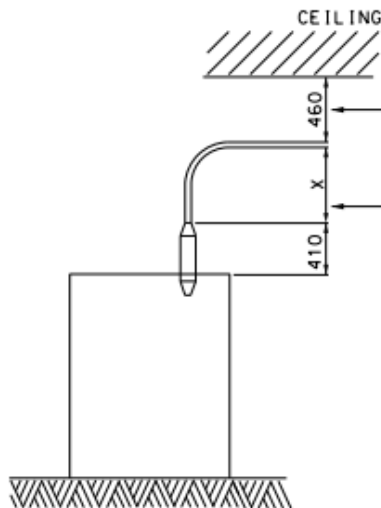

FIGURE 3

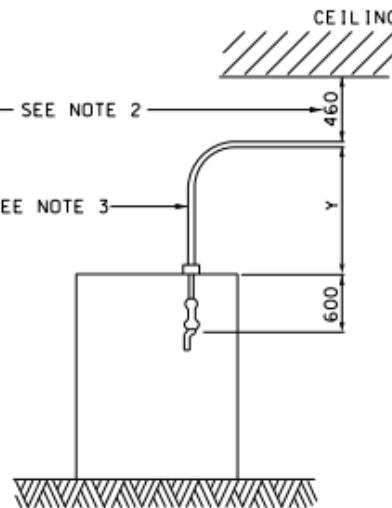





FIGURE 4

CABLE SIZE	X		Y
	PILC (15 kV)	XLPE (15 kV)	XLPE (28 kV)
#1/0			350
#2/0	610		
#3/0		300	
350 KCMIL	750		
500 KCMIL	830	400	
1000 KCMIL			680

LEGEND

-  STRAIN RELIEF CONNECTOR
-  CLASS 1 CABLE TERMINATION (POTHEAD)
-  CLASS 1 CABLE TERMINATION (COLD SHRINK OR HEAT SHRINK KIT)

NOTES:

- 1) ALL DIMENSIONS ARE IN MILLIMETRES.
- 2) DIMENSION SHOWN IS ALLOWANCE FOR RACKING CABLES TO CEILING
- 3) HIGH VOLTAGE CABLES IN THE CUSTOMER VAULT SHALL BE GUARDED BY BARRIERS. CABLES BARRIERS OR CABLES TRENCH ACCESS HATCHES SHALL HAVE PROVISIONS FOR PADLOCKS.

SKETCH 2

TORONTO HYDRO INCOMING FEEDER TERMINATIONS

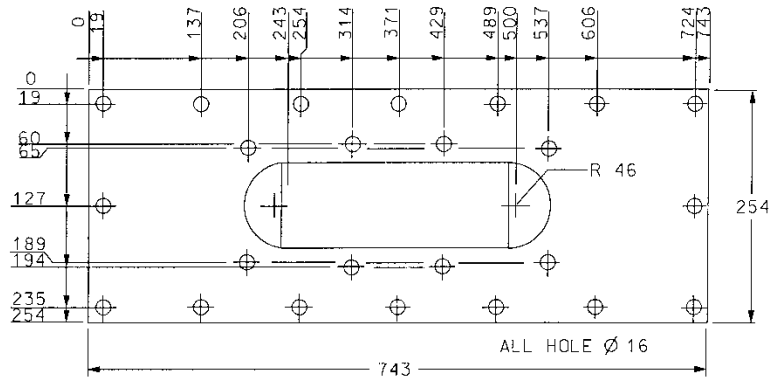

MOUNTING PLATE (6 mm THICK)

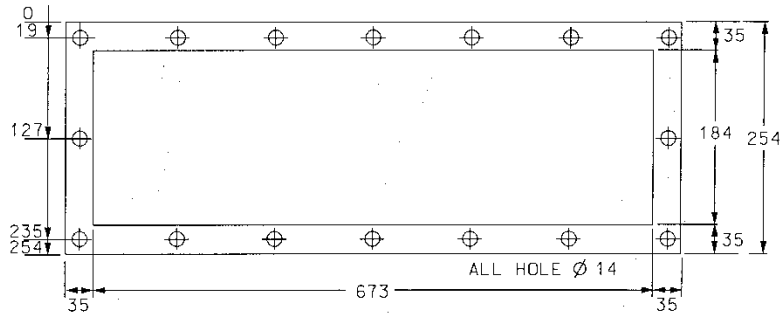

MOUNTING PLATE GASKET (3 mm THICK)

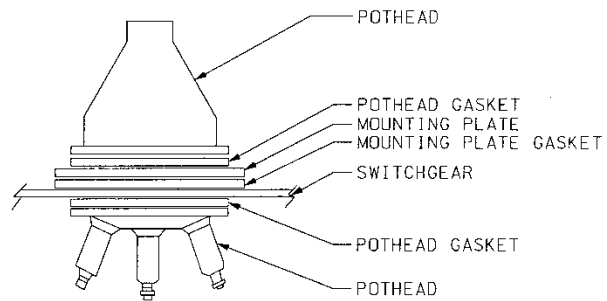

DETAIL 'A'

NOTES:

1) ALL DIMENSIONS ARE IN MILLIMETRES.

SKETCH 3
POTHEAD MOUNTING PLATES AND GASKET STANDARD
(FOR TOP ENTRY TERMINATION)

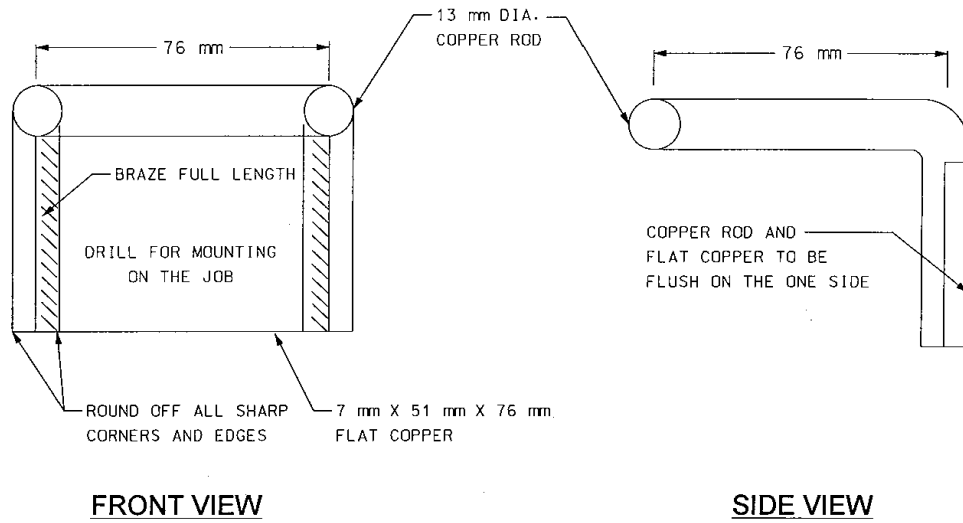

NOTE:
1) SILVER PLATE COMPLETED GROUND STIRRUP ASSEMBLY.

**SKETCH 4 (A-1)
GROUNDING STIRRUP
ANGLED**

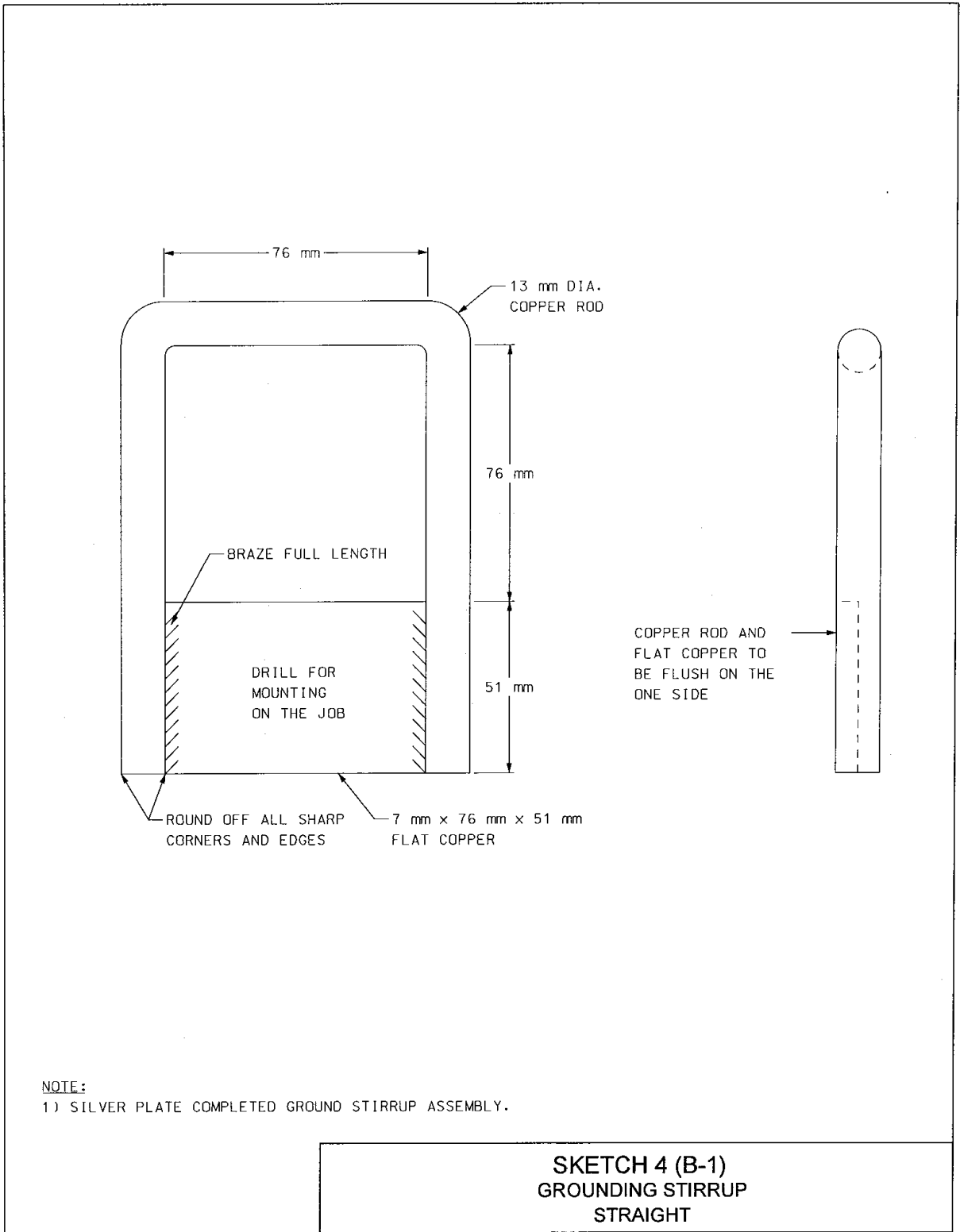

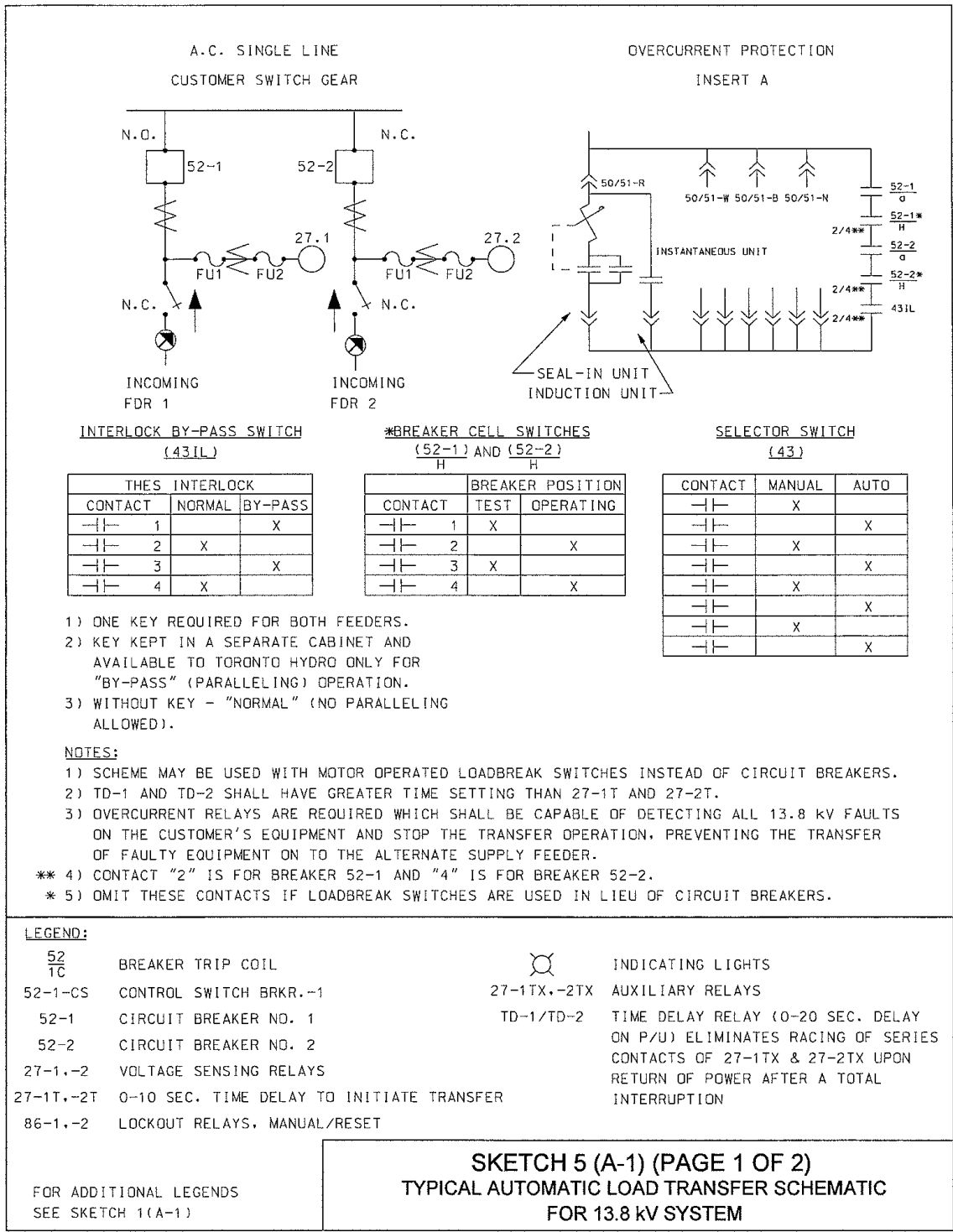

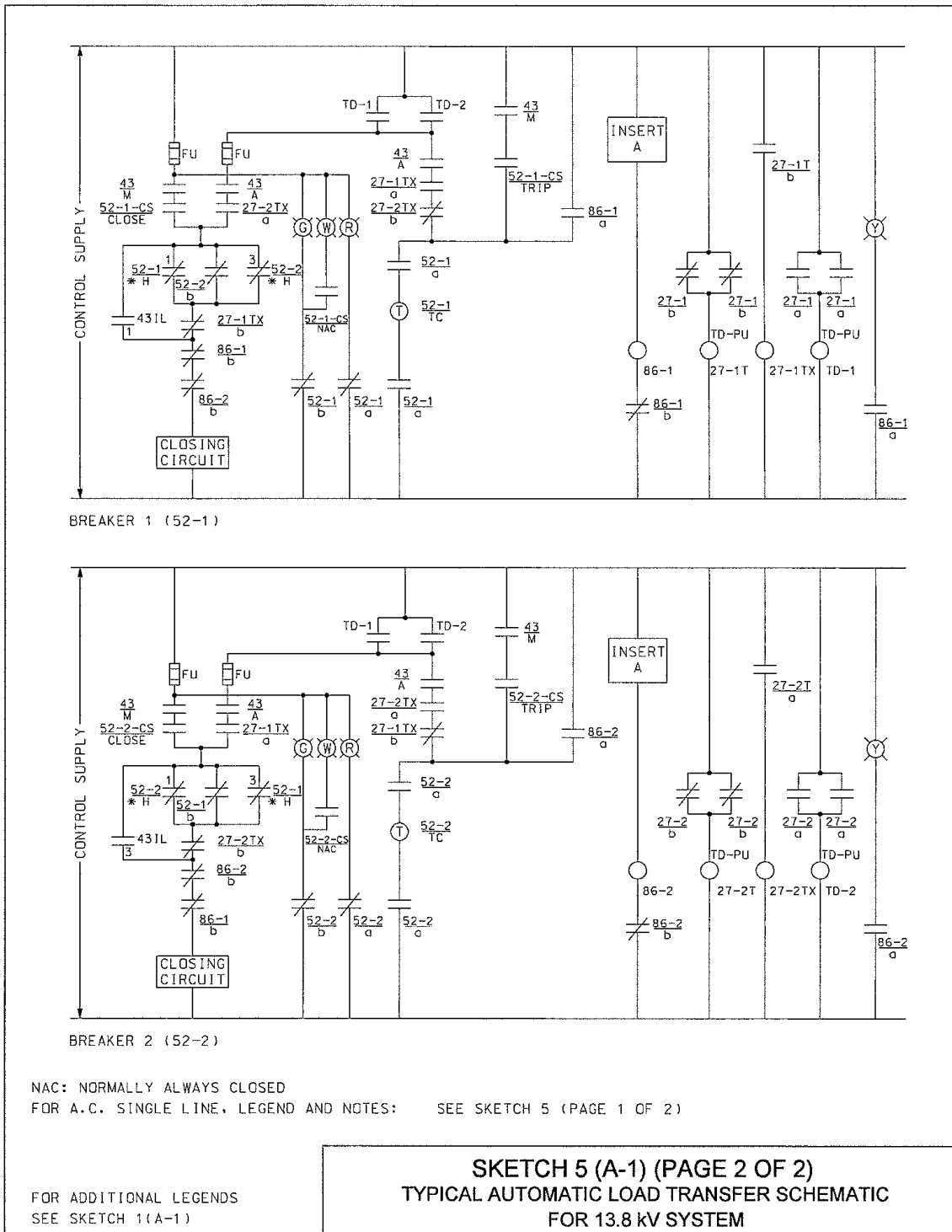



Arc Flash and Shock Hazard
Appropriate PPE Required

ARC FLASH PROTECTION

Working distance: ___ mm System Voltage: ___ Vac
Incident energy: ___ cal/cm²
Arc Flash Boundary: ___ m
PPE Level: 1, 2, 3, or 4

Manufacturer Name: company XYZ
Equipment Identification: e.g. SWGR-P2C
Station and Feeder Designation: e.g. Windsor A-19-WR
Arc Flash Analysis by: Organization name MM/DD/YYYY
Calculations based on: IEEE 1584 or Lee methods

SKETCH 7
ARC FLASH SIGN